

# **Protection of Electrical Networks**

Christophe Prévé

**ISTE**

First published in Great Britain and the United States in 2006 by ISTE Ltd

Apart from any fair dealing for the purposes of research or private study, or criticism or review, as permitted under the Copyright, Designs and Patents Act 1988, this publication may only be reproduced, stored or transmitted, in any form or by any means, with the prior permission in writing of the publishers, or in the case of reprographic reproduction in accordance with the terms and licenses issued by the CLA. Enquiries concerning reproduction outside these terms should be sent to the publishers at the undermentioned address:

ISTE Ltd  
6 Fitzroy Square  
London W1T 5DX  
UK

ISTE USA  
4308 Patrice Road  
Newport Beach, CA 92663  
USA

[www.iste.co.uk](http://www.iste.co.uk)

© ISTE Ltd, 2006

The rights of Christophe Prévé to be identified as the author of this work have been asserted by him in accordance with the Copyright, Designs and Patents Act 1988.

---

Library of Congress Cataloging-in-Publication Data

Prévé, Christophe, 1964-  
Protection of electrical networks / Christophe Prévé.  
p. cm.  
Includes index.  
ISBN-13: 978-1-905209-06-4  
ISBN-10: 1-905209-06-1  
1. Electric networks--Protection. I. Title.  
TK454.2.P76 2006  
621.319'2--dc22

2006008664

---

British Library Cataloguing-in-Publication Data

A CIP record for this book is available from the British Library  
ISBN 10: 1-905209-06-1  
ISBN 13: 978-1-905209-06-4

---

Printed and bound in Great Britain by Antony Rowe Ltd, Chippenham, Wiltshire.

## Table of Contents

<b>Chapter 1. Network Structures</b> . . . . .	11
1.1. General structure of the private distribution network . . . . .	13
1.2. The supply source . . . . .	13
1.3. HV consumer substations . . . . .	13
1.4. MV power supply . . . . .	16
1.4.1. Different MV service connections . . . . .	16
1.4.2. MV consumer substations . . . . .	19
1.5. MV networks inside the site . . . . .	19
1.5.1. MV switchboard power supply modes . . . . .	19
1.5.2. MV network structures . . . . .	25
1.6. LV networks inside the site . . . . .	31
1.6.1. LV switchboard supply modes . . . . .	31
1.6.2. LV switchboards backed up by generators . . . . .	35
1.6.3. LV switchboards backed up by an uninterruptible power supply (UPS) . . . . .	36
1.7. Industrial networks with internal generation . . . . .	42
1.8. Examples of standard networks . . . . .	44
<b>Chapter 2. Earthing Systems</b> . . . . .	53
2.1. Earthing systems at low voltage . . . . .	54
2.1.1. Different earthing systems – definition and arrangements . . . . .	55
2.1.2. Comparison of different earthing systems in low voltage . . . . .	58
2.1.2.1. Unearthed or impedance-earthed neutral (IT system) . . . . .	58
2.1.2.2. Directly earthed neutral (TT system) . . . . .	59
2.1.2.3. Connecting the exposed conductive parts to the neutral (TNC – TNS systems) . . . . .	60
2.2. Medium voltage earthing systems . . . . .	61
2.2.1. Different earthing systems – definition and arrangements . . . . .	61
2.2.2. Comparison of different medium voltage earthing systems . . . . .	63
2.2.2.1. Direct earthing . . . . .	63
2.2.2.2. Unearthed . . . . .	63
2.2.2.3. Limiting resistance earthing . . . . .	64

6 Protection of Electrical Networks

2.2.2.4. Limiting reactance earthing . . . . .	64
2.2.2.5. Peterson coil earthing . . . . .	65
2.3. Creating neutral earthing . . . . .	66
2.3.1. MV installation resistance earthing . . . . .	66
2.3.2. Reactance or Petersen coil earthing of an MV installation. . . . .	70
2.3.3. Direct earthing of an MV or LV installation . . . . .	70
2.4. Specific installation characteristics in LV unearthed systems . . . . .	70
2.4.1. Installing a permanent insulation monitor . . . . .	71
2.4.2. Installing an overvoltage limiter . . . . .	71
2.4.3. Location of earth faults by a low frequency generator (2–10 Hz) . . . . .	71
2.5. Specific installation characteristics of an MV unearthed system . . . . .	73
2.5.1. Insulation monitoring . . . . .	73
2.5.2. Location of the first insulation fault . . . . .	75
<b>Chapter 3. Main Faults Occurring in Networks and Machines . . . . .</b>	<b>77</b>
3.1. Short-circuits . . . . .	77
3.1.1. Short-circuit characteristics . . . . .	77
3.1.2. Different types of short-circuits . . . . .	78
3.1.3. Causes of short-circuits . . . . .	79
3.2. Other types of faults. . . . .	80
<b>Chapter 4. Short-circuits . . . . .</b>	<b>81</b>
4.1. Establishment of short-circuit currents and wave form . . . . .	82
4.1.1. Establishment of the short-circuit at the utility’s supply terminals . . . . .	83
4.1.2. Establishment of the short-circuit current at the terminals of a generator. . . . .	87
4.2. Short-circuit current calculating method. . . . .	92
4.2.1. Symmetrical three-phase short-circuit. . . . .	93
4.2.1.1. Equivalent impedance of an element across a transformer. . . . .	94
4.2.1.2. Impedance of parallel links . . . . .	95
4.2.1.3. Expression of impedances as a percentage and short-circuit voltage as a percentage . . . . .	96
4.2.1.4. Impedance values of different network elements . . . . .	98
4.2.1.5. Contribution of motors to the short-circuit current value . . . . .	106
4.2.1.6. Example of a symmetrical three-phase short-circuit calculation . . . . .	107
4.2.2. Solid phase-to-earth short-circuit (zero fault impedance) . . . . .	114
4.2.2.1. positive, negative and zero-sequence impedance values of different network elements . . . . .	117
4.2.3. The phase-to-phase short-circuit clear of earth . . . . .	125
4.2.4. The two-phase-to-earth short-circuit. . . . .	125
4.3. Circulation of phase-to-earth fault currents . . . . .	126
4.3.1. Unearthed or highly impedant neutral. . . . .	129
4.3.2. Impedance-earthed neutral (resistance or reactance) . . . . .	130
4.3.3. Tuned reactance or Petersen coil earthing . . . . .	131
4.3.4. Directly earthed neutral . . . . .	132

4.3.5. Spreading of the capacitive current in a network with several outgoing feeders upon occurrence of an earth fault . . . . .	133
4.4. Calculation and importance of the minimum short-circuit current . . . . .	137
4.4.1. Calculating the minimum short-circuit current in low voltage in relation to the earthing system . . . . .	138
4.4.1.1. Calculating the minimum short-circuit current in a TN system . . . . .	139
4.4.1.2. Calculating the minimum short-circuit current in an IT system without a distributed neutral . . . . .	144
4.4.1.3. Calculating the minimum short-circuit in an IT system with distributed neutral . . . . .	150
4.4.1.4. Calculating the minimum short-circuit in a TT system. . . . .	151
4.4.1.5. Influence of the minimum short-circuit current on the choice of circuit-breakers or fuses . . . . .	156
4.4.2. Calculating the minimum short-circuit current for medium and high voltages. . . . .	160
4.4.3. Importance of the minimum short-circuit calculation for protection selectivity . . . . .	162
<b>Chapter 5. Consequences of Short-circuits . . . . .</b>	<b>163</b>
5.1. Thermal effect . . . . .	163
5.2. Electrodynamic effect. . . . .	165
5.3. Voltage drops. . . . .	167
5.4. Transient overvoltages . . . . .	168
5.5. Touch voltages . . . . .	169
5.6. Switching surges. . . . .	169
5.7. Induced voltage in remote control circuits. . . . .	170
<b>Chapter 6. Instrument Transformers . . . . .</b>	<b>173</b>
6.1. Current transformers . . . . .	173
6.1.1. Theoretical reminder . . . . .	173
6.1.2. Saturation of the magnetic circuit . . . . .	176
6.1.3. Using CTs in electrical networks. . . . .	181
6.1.3.1. General application rule . . . . .	181
6.1.3.2. Composition of a current transformer . . . . .	182
6.1.3.3. Specifications and definitions of current transformer parameters. . . . .	183
6.1.3.4. Current transformers used for measuring in compliance with standard IEC 60044-1 . . . . .	185
6.1.3.5. Current transformers used for protection in compliance with standard IEC 60044-1 . . . . .	187
6.1.3.6. Current transformers used for protection in compliance with BS 3938 (class X) . . . . .	188
6.1.3.7. Correspondence between IEC 60044-1 and BS 3938 CT specifications . . . . .	189
6.1.3.8. Use of CTs outside their nominal values . . . . .	192
6.1.3.9. Example of a current transformer rating plate . . . . .	197
6.1.4. Non-magnetic current sensors . . . . .	197

8 Protection of Electrical Networks

6.2. Voltage transformers . . . . .	198
6.2.1. General application rule . . . . .	198
6.2.2. Specifications and definitions of voltage transformer parameters . . . . .	199
6.2.3. Voltage transformers used for measuring in compliance with IEC 60044-2. . . . .	202
6.2.4. Voltage transformers used for protection in compliance with IEC 60044-2. . . . .	203
6.2.5. Example of the rating plate of a voltage transformer used for measurement . . . . .	205
<b>Chapter 7. Protection Functions and their Applications . . . . .</b>	<b>207</b>
7.1. Phase overcurrent protection (ANSI code 50 or 51) . . . . .	208
7.2. Earth fault protection (ANSI code 50 N or 51 N, 50 G or 51 G). . . . .	210
7.3. Directional overcurrent protection (ANSI code 67) . . . . .	214
7.3.1. Operation. . . . .	217
7.4. Directional earth fault protection (ANSI code 67 N) . . . . .	224
7.4.1. Operation. . . . .	226
7.4.2. Study and setting of parameters for a network with limiting resistance earthing . . . . .	228
7.4.3. Study and setting of parameters for an unearthed network. . . . .	234
7.5. Directional earth fault protection for compensated neutral networks (ANSI code 67 N). . . . .	238
7.6. Differential protection . . . . .	243
7.6.1. High impedance differential protection . . . . .	244
7.6.1.1. Operation and dimensioning of elements . . . . .	246
7.6.1.2. Application of high impedance differential protection . . . . .	256
7.6.1.3. Note about the application of high impedance differential protection . . . . .	265
7.6.2. Pilot wire differential protection for cables or lines (ANSI code 87 L) . . . . .	265
7.6.3. Transformer differential protection (ANSI code 87 T) . . . . .	276
7.7. Thermal overload protection (ANSI code 49). . . . .	279
7.8. Negative phase unbalance protection (ANSI code 46) . . . . .	288
7.9. Excessive start-up time and locked rotor protection (ANSI code 51 LR) . . . . .	292
7.10. Protection against too many successive start-ups (ANSI code 66). . . . .	294
7.11. Phase undercurrent protection (ANSI code 37) . . . . .	295
7.12. Undervoltage protection (ANSI code 27) . . . . .	297
7.13. Remanent undervoltage protection (ANSI code 27) . . . . .	298
7.14. Positive sequence undervoltage and phase rotation direction protection (ANSI code 27 d – 47) . . . . .	298
7.15. Overvoltage protection (ANSI code 59) . . . . .	300
7.16. Residual overvoltage protection (ANSI code 59 N) . . . . .	301
7.17. Under or overfrequency protection (ANSI code 81) . . . . .	302
7.18. Protection against reversals in reactive power (ANSI code 32 Q) . . . . .	303
7.19. Protection against reversals in active power (ANSI code 32 P) . . . . .	304
7.20. Tank earth leakage protection (ANSI code 50 or 51) . . . . .	306

7.21. Protection against neutral earthing impedance overloads (ANSI code 50 N or 51 N) . . . . .	307
7.22. Overall network earth fault protection by monitoring the current flowing through the earthing connection (ANSI code 50 N or 51 N, 50 G or 51 G) . . . . .	308
7.23. Protection using temperature monitoring (ANSI code 38 – 49 T) . . . . .	309
7.24. Voltage restrained overcurrent protection (ANSI code 50 V or 51 V) . . . . .	311
7.25. Protection by gas, pressure and temperature detection (DGPT) . . . . .	314
7.26. Neutral to neutral unbalance protection (ANSI code 50 N or 51 N) . . . . .	315
<b>Chapter 8. Overcurrent Switching Devices</b> . . . . .	<b>317</b>
8.1. Low voltage circuit-breakers . . . . .	317
8.2. MV circuit-breakers (according to standard IEC 62271-100) . . . . .	325
8.3. Low voltage fuses . . . . .	331
8.3.1. Fusing zones – conventional currents . . . . .	331
8.3.2. Breaking capacity . . . . .	334
8.4. MV fuses . . . . .	334
<b>Chapter 9. Different Selectivity Systems</b> . . . . .	<b>341</b>
9.1. Amperemetric selectivity . . . . .	341
9.2. Time-graded selectivity . . . . .	345
9.3. Logic selectivity . . . . .	349
9.4. Directional selectivity . . . . .	354
9.5. Selectivity by differential protection . . . . .	355
9.6. Selectivity between fuses and circuit-breakers . . . . .	356
<b>Chapter 10. Protection of Network Elements</b> . . . . .	<b>361</b>
10.1. Network protection . . . . .	361
10.1.1. Earth fault requirements for networks earthed via a limiting resistance (directly or by using an artificial neutral) . . . . .	362
10.1.2. Earth fault requirement for unearthed networks . . . . .	369
10.1.3. Requirements for phase-to-phase faults . . . . .	371
10.1.4. Network with one incoming feeder . . . . .	372
10.1.4.1. Protection against phase-to-phase faults . . . . .	373
10.1.4.2. Protection against earth faults . . . . .	375
10.1.5. Network with two parallel incoming feeders . . . . .	381
10.1.5.1. Protection against phase-to-phase faults . . . . .	381
10.1.5.2. Protection against earth faults . . . . .	384
10.1.6. Network with two looped incoming feeders . . . . .	390
10.1.6.1. Protection against phase-to-phase faults . . . . .	390
10.1.6.2. Protection against earth faults . . . . .	393
10.1.7. Loop network . . . . .	399
10.1.7.1. Protection at the head of the loop . . . . .	399
10.1.8. Protection by section . . . . .	401
10.2. Busbar protection . . . . .	412
10.2.1. Protection of a busbar using logic selectivity . . . . .	412

10 Protection of Electrical Networks

10.2.2. Protection of a busbar using a high impedance differential protection . . . . .	413
10.3. Transformer protection . . . . .	414
10.3.1. Transformer energizing inrush current. . . . .	414
10.3.2. Value of the short-circuit current detected by the HV side protection during a short-circuit on the LV side for a delta-star transformer . . . . .	417
10.3.3. Faults in transformers. . . . .	423
10.3.4. Transformer protection. . . . .	424
10.3.4.1. Specific protection against overloads . . . . .	424
10.3.4.2. Specific protection against internal phase short-circuits . . . . .	424
10.3.4.3. Specific protection against earth faults . . . . .	424
10.3.4.4. Switch-fuse protection . . . . .	425
10.3.4.5. Circuit-breaker protection . . . . .	432
10.3.5. Examples of transformer protection . . . . .	436
10.3.6. Transformer protection setting indications . . . . .	438
10.4. Motor protection . . . . .	439
10.4.1. Protection of medium voltage motors . . . . .	440
10.4.1.1. Examples of motor protection. . . . .	446
10.4.1.2. Motor protection setting indications . . . . .	448
10.4.2. Protection of low voltage asynchronous motors . . . . .	451
10.5. AC generator protection. . . . .	452
10.5.1. Examples of generator protection devices. . . . .	457
10.5.2. Generator protection setting indications. . . . .	460
10.6. Capacitor bank protection . . . . .	462
10.6.1. Electrical phenomena related to energization. . . . .	463
10.6.2. Protection of Schneider low voltage capacitor banks . . . . .	469
10.6.3. Protection of Schneider medium voltage capacitor banks . . . . .	470
10.8. Protection of direct current installations . . . . .	479
10.8.1. Short-circuit current calculation . . . . .	479
10.8.2. Characteristics of insulation faults and switchgear . . . . .	482
10.8.3. Protection of persons . . . . .	483
10.9. Protection of uninterruptible power supplies (UPS) . . . . .	483
10.9.1. Choice of circuit-breaker ratings . . . . .	484
10.9.2. Choice of circuit-breaker breaking capacity . . . . .	485
10.9.3. Selectivity requirements . . . . .	485
<b>Appendix A. Transient Current Calculation of Short-circuit Fed by Utility Network. . . . .</b>	<b>487</b>
<b>Appendix B. Calculation of Inrush Current During Capacitor Bank Energization. . . . .</b>	<b>493</b>
<b>Appendix C. Voltage Peak Value and Current r m.s Value, at the Secondary of a Saturated Current Transformer . . . . .</b>	<b>501</b>
<b>Index . . . . .</b>	<b>507</b>



# Chapter 1

## Network Structures

### Definition

Standard IEC 60038 defines voltage ratings as follows:

- *Low voltage (LV)*: for a phase-to-phase voltage of between 100 V and 1,000 V, the standard ratings are: 400 V - 690 V - 1,000 V (at 50 Hz).
- *Medium voltage (MV)*: for a phase-to-phase voltage between 1,000 V and 35 kV, the standard ratings are: 3.3 kV - 6.6 kV - 11 kV - 22 kV - 33 kV.
- *High voltage (HV)*: for a phase-to-phase voltage between 35 kV and 230 kV, the standard ratings are: 45 kV - 66 kV - 110 kV - 132 kV - 150 kV - 220 kV.

In this chapter we will look at:

- types of HV and MV consumer substations;
- structure of MV networks inside a site;
- structure of LV networks inside a site;
- structure of systems with a back-up power supply.

Six standard examples of industrial network structures are given at the end of the chapter.

Each structure is commented upon and divided up so that each functional aspect can be considered.

(NC) means that the switch or circuit-breaker is closed in normal conditions.

(NO) means that the switch or circuit-breaker is open in normal conditions.

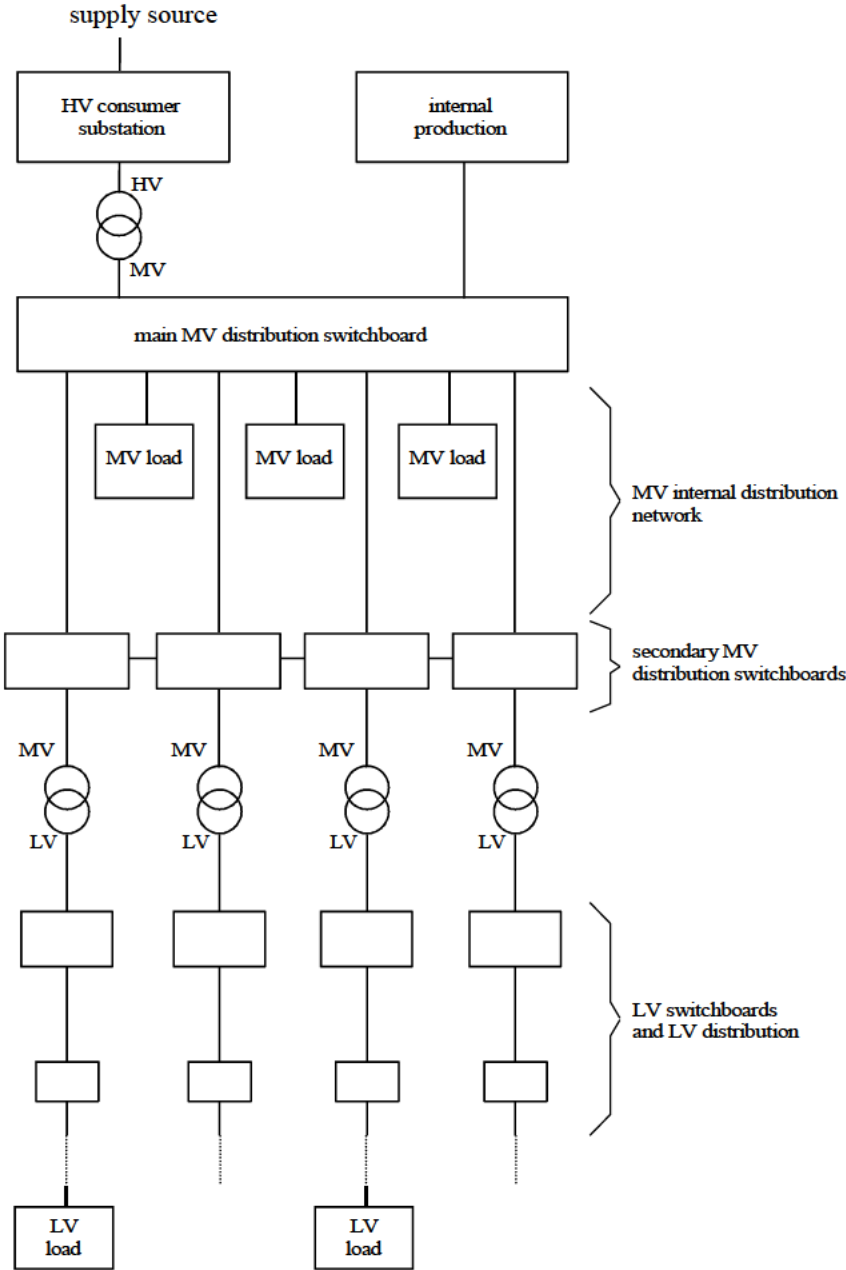


Figure 1-1: structure of a private distribution network

### 1.1. General structure of the private distribution network

Generally, with an HV power supply, a private distribution network comprises (see Figure 1-1):

- an HV consumer substation fed by one or more sources and made up of one or more busbars and circuit-breakers;
- an internal generation source;
- one or more HV/MV transformers;
- a main MV switchboard made up of one or more busbars;
- an internal MV network feeding secondary switchboards or MV/LV substations;
- MV loads;
- MV/LV transformers;
- low voltage switchboards and networks;
- low voltage loads.

### 1.2. The supply source

The power supply of industrial networks can be LV, MV or HV. The voltage rating of the supply source depends on the consumer supply power. The greater the power required, the higher the voltage must be.

### 1.3. HV consumer substations

The most usual supply arrangements adopted in HV consumer substations are:

#### *Single power supply (see Figure 1-2)*

Advantage:

- reduced cost.

Disadvantage:

- low reliability.

Note: the isolators associated with the HV circuit-breakers have not been shown.

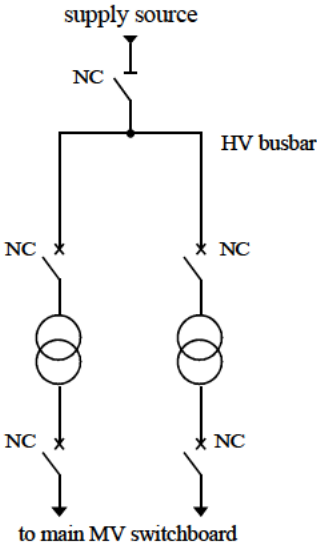


Figure 1-2: single fed HV consumer substation

Dual power supply (see Figure 1-3)

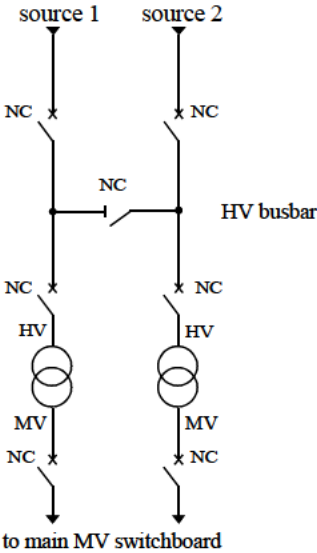


Figure 1-3: dual fed HV consumer substation

Operating mode:

– normal:

- Both incoming circuit-breakers are closed, as well as the coupler isolator.
- The transformers are thus simultaneously fed by two sources.

– disturbed:

- If one source is lost, the other provides the total power supply.

Advantages:

- Very reliable in that each source has a total network capacity.
- Maintenance of the busbar possible while it is still partially operating.

Disadvantages:

- More costly solution.
- Only allows partial operation of the busbar if maintenance is being carried out on it.

Note: the isolators associated with the HV circuit-breakers have not been shown.

***Dual fed double bus system (see Figure 1-4)***

Operating mode:

– normal:

- Source 1 feeds busbar BB1 and feeders Out1 and Out2.
- Source 2 feeds busbar BB2 and feeders Out3 and Out4.
- The bus coupler circuit-breaker can be kept closed or open.

– disturbed:

- If one source is lost, the other provides the total power supply.
- If a fault occurs on a busbar (or maintenance is carried out on it), the bus coupler circuit-breaker is tripped and the other busbar feeds all the outgoing lines.

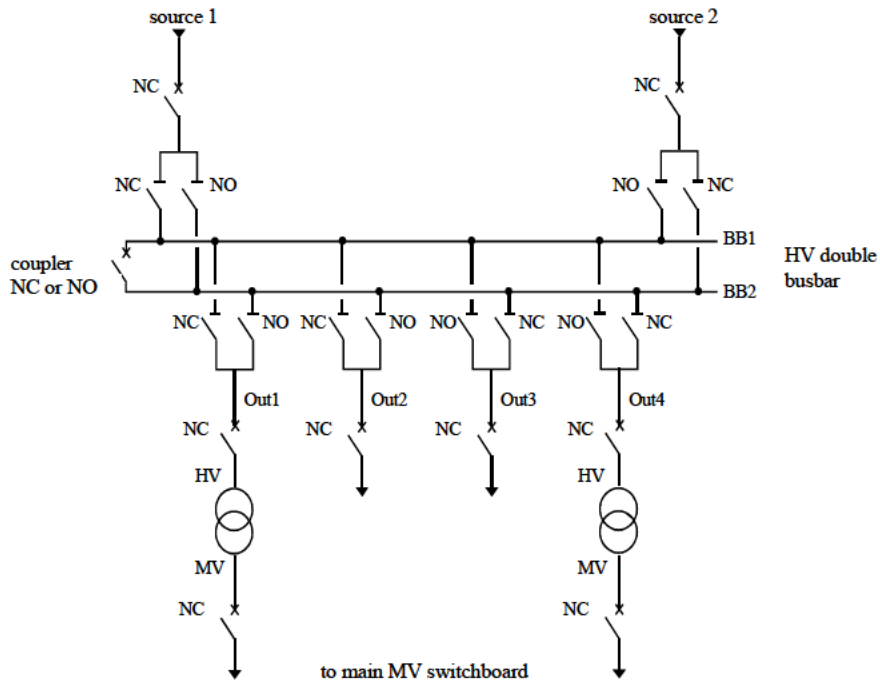
Advantages:

- Reliable power supply.
- Highly flexible use for the attribution of sources and loads and for busbar maintenance.
- Busbar transfer possible without interruption.

Disadvantage:

- More costly in relation to the single busbar system.

Note: the isolators associated with the HV circuit-breakers have not been shown.



**Figure 1-4:** dual fed double bus HV consumer substation

#### 1.4. MV power supply

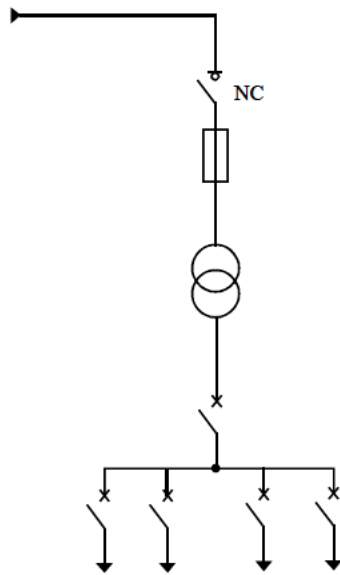
We shall first look at the different MV service connections and then at the MV consumer substation.

##### 1.4.1. Different MV service connections

Depending on the type of MV network, the following supply arrangements are commonly adopted.

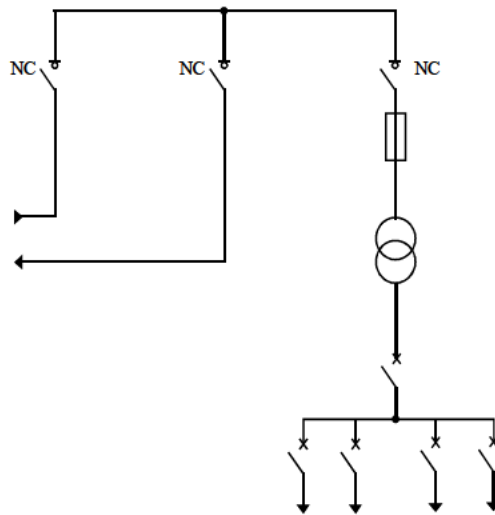
##### *Single line service (see Figure 1-5)*

The substation is fed by a single circuit tee-off from an MV distribution (cable or line). Transformer ratings of up to 160 kVA of this type of MV service is very common in rural areas. It has one supply source via the utility.



**Figure 1-5:** *single line service*

*Ring main principle (see Figure 1-6)*

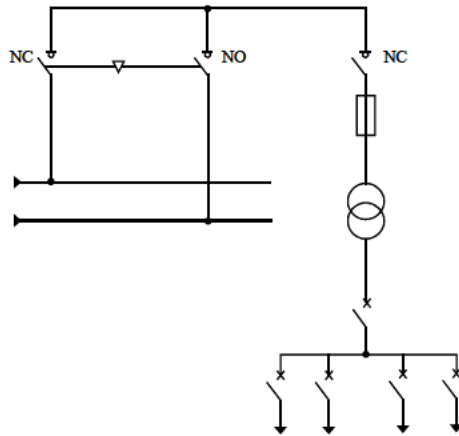


**Figure 1-6:** *ring main service*

Ring main units (RMU) are normally connected to form an MV ring main or loop (see Figures 1-20a and 1-20b).

This arrangement provides the user with a two-source supply, thereby considerably reducing any interruption of service due to system faults or operational maneuvers by the supply authority. The main application for RMUs is in utility MV underground cable networks in urban areas.

**Parallel feeder (see Figure 1-7)**



**Figure 1-7:** *duplicated supply service*

When an MV supply connection to two lines or cables originating from the same busbar of a substation is possible, a similar MV switchboard to that of an RMU is commonly used (see Figure 1-21).

The main operational difference between this arrangement and that of an RMU is that the two incoming switches are mutually interlocked, in such a way that only one incoming switch can be closed at a time, i.e. its closure prevents that of the other.

On loss of power supply, the closed incoming switch must be opened and the (formerly open) switch can then be closed. The sequence may be carried out manually or automatically. This type of switchboard is used particularly in networks of high load density and in rapidly expanding urban areas supplied by MV underground cable systems.



**1.4.2. MV consumer substations**

The MV consumer substation may comprise several MV transformers and outgoing feeders. The power supply may be a single line service, ring main principle or parallel feeder (see section 1.4.1).

Figure 1-8 shows the arrangement of an MV consumer substation using a ring main supply with MV transformers and outgoing feeders.

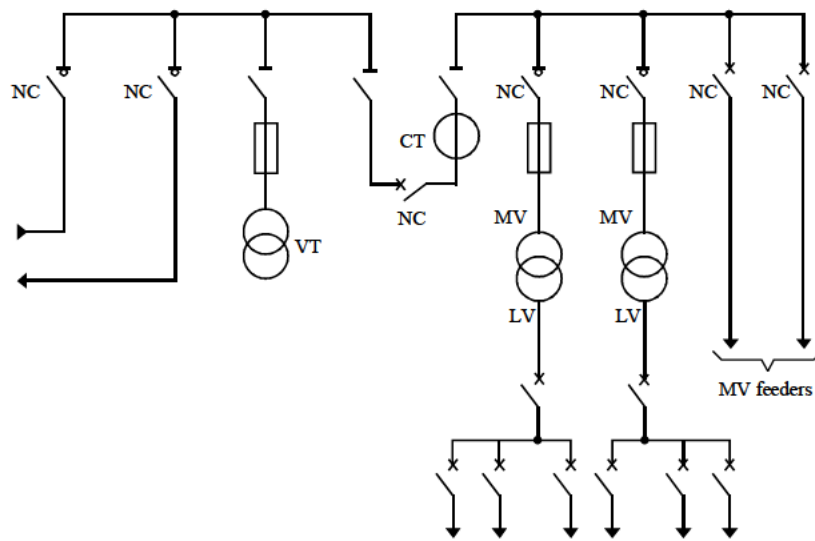


Figure 1-8: example of MV consumer substation

**1.5. MV networks inside the site**

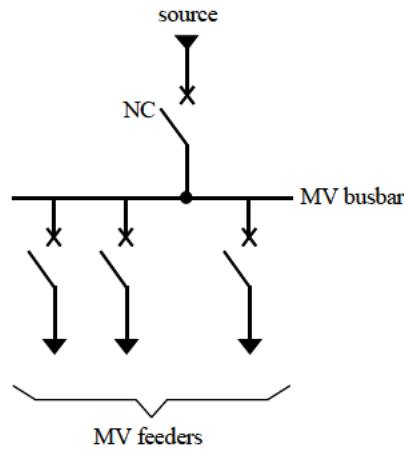
MV networks are made up of switchboards and the connections feeding them. We shall first of all look at the different supply modes of these switchboards, then the different network structures allowing them to be fed.

**1.5.1. MV switchboard power supply modes**

We shall start with the main power supply solutions of an MV switchboard, regardless of its place in the network.

The number of sources and the complexity of the switchboard differ according to the level of power supply security required.

**1 busbar, 1 supply source (see Figure 1-9)**

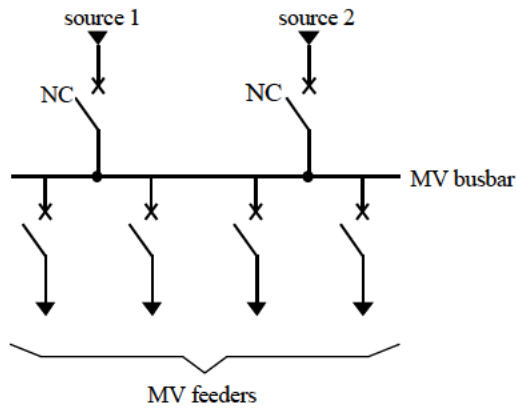


**Figure 1-9: 1 busbar, 1 supply source**

Operation: if the supply source is lost, the busbar is put out of service until the fault is repaired.

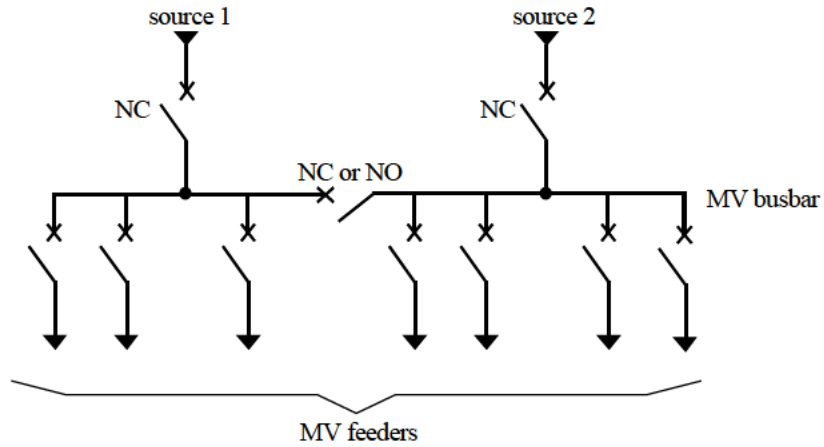
**1 busbar with no coupler, 2 supply sources (see Figure 1-10)**

Operation: one source feeds the busbar, the other provides a back-up supply. If a fault occurs on the busbar (or maintenance is carried out on it), the outgoing feeders are no longer fed.



**Figure 1-10: 1 busbar with no coupler, 2 supply sources**

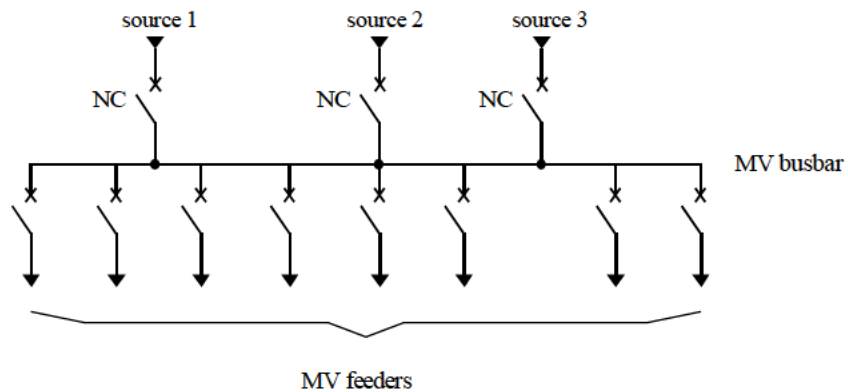
**2 bus sections with coupler, 2 supply sources (see Figure 1-11)**



**Figure 1-11: 2 bus sections with coupler, 2 supply sources**

Operation: each source feeds one bus section. The bus coupler circuit-breaker can be kept closed or open. If one source is lost, the coupler circuit-breaker is closed and the other source feeds both bus sections. If a fault occurs in a bus section (or maintenance is carried out on it), only one part of the outgoing feeders is no longer fed.

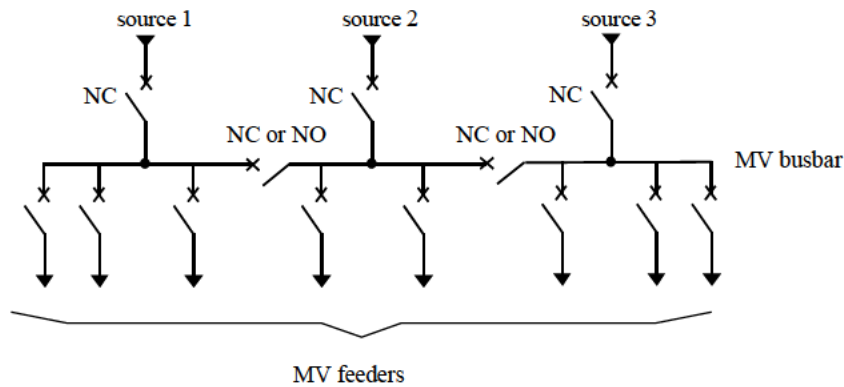
**1 busbar with no coupler, 3 supply sources (see Figure 1-12)**



**Figure 1-12: 1 busbar with no coupler, 3 supply sources**

Operation: the power supply is normally provided by two parallel-connected sources. If one of these two sources is lost, the third provides a back-up supply. If a fault occurs on the busbar (or maintenance is carried out on it), the outgoing feeders are no longer fed.

**3 bus sections with couplers, 3 supply sources (see Figure 1-13)**



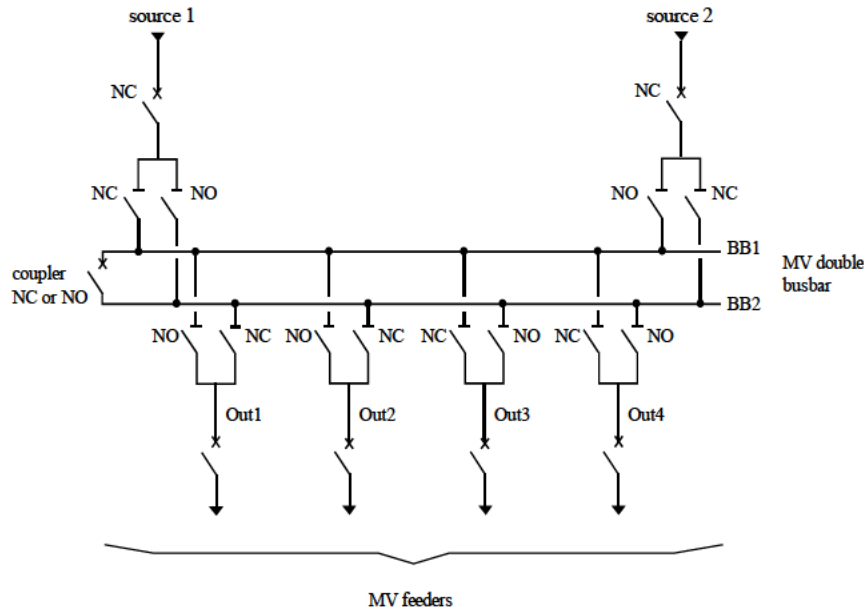
**Figure 1-13: 3 bus sections with couplers, 3 supply sources**

Operation: both bus coupler circuit-breakers can be kept open or closed. Each supply source feeds its own bus section. If one source is lost, the associated coupler circuit-breaker is closed, one source feeds two bus sections and the other feeds one bus section. If a fault occurs on one bus section (or if maintenance is carried out on it), only one part of the outgoing feeders is no longer fed.

**2 busbars, 2 connections per outgoing feeder, 2 supply sources (see Figure 1-14)**

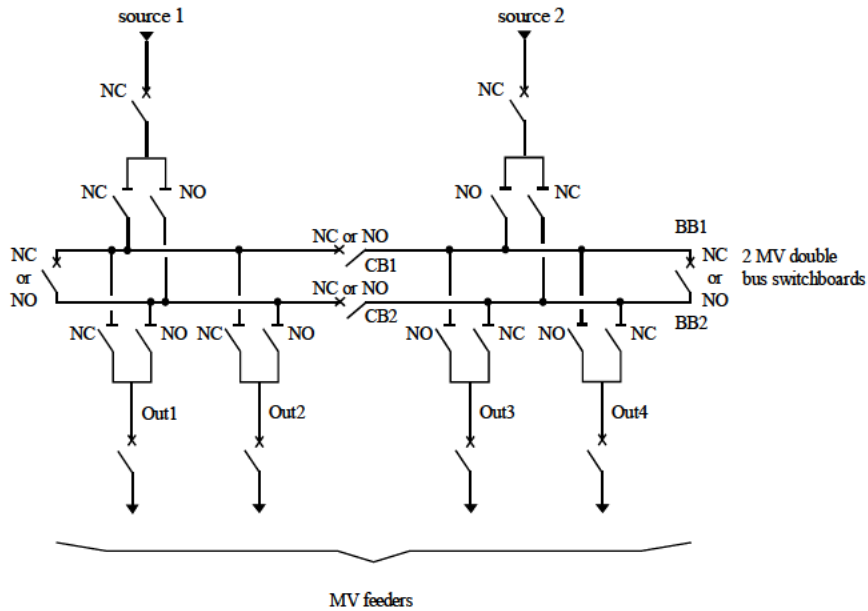
Operation: each outgoing feeder can be fed by one or other of the busbars, depending on the state of the isolators which are associated with it, and only one isolator per outgoing feeder must be closed.

For example, source 1 feeds busbar BB1 and feeders Out1 and Out2. Source 2 feeds busbar BB2 and feeders Out3 and Out4. The bus coupler circuit-breaker can be kept closed or open during normal operation. If one source is lost, the other source takes over the total power supply. If a fault occurs on a busbar (or maintenance is carried out on it), the coupler circuit-breaker is opened and the other busbar feeds all the outgoing feeders.



**Figure 1-14:** 2 busbars, 2 connections per outgoing feeder, 2 supply sources

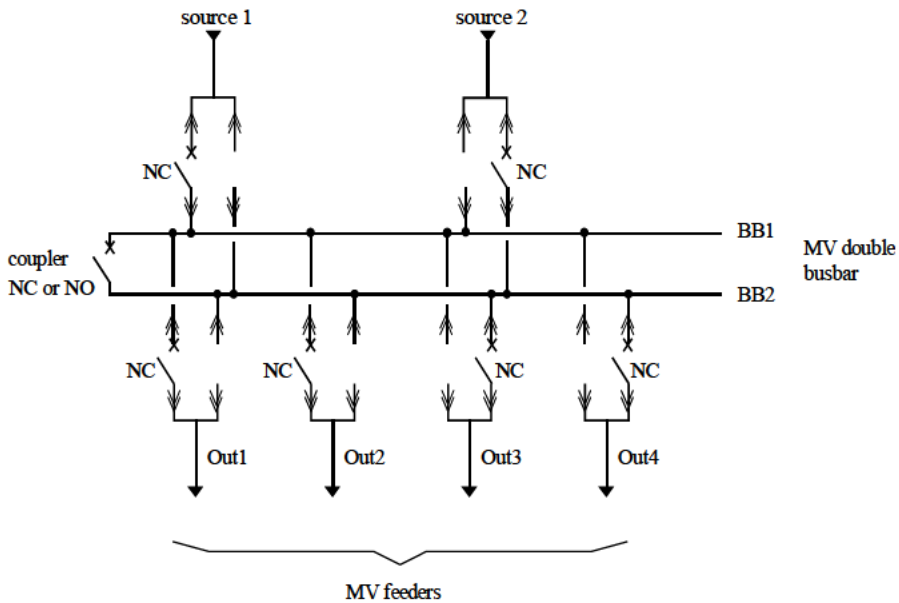
**2 interconnected double busbars (see Figure 1-15)**



**Figure 1-15:** 2 interconnected double busbars

Operation: this arrangement is almost identical to the previous one (two busbars, two connections per feeder, two supply sources). The splitting up of the double busbars into two switchboards with coupler (via CB1 and CB2) provides greater operating flexibility. Each busbar feeds a smaller number of feeders during normal operation.

**“Duplex” distribution system (see Figure 1-16)**



**Figure 1-16: “duplex” distribution system**

Operation: each source can feed one or other of the busbars via its two drawout circuit-breaker cubicles. For economic reasons, there is only one circuit-breaker for the two drawout cubicles, which are installed alongside one another. It is thus easy to move the circuit-breaker from one cubicle to the other. Thus, if source 1 is to feed busbar BB2, the circuit-breaker is moved into the other cubicle associated with source 1.

The same principle is used for the outgoing feeders. Thus, there are two drawout cubicles and only one circuit-breaker associated with each outgoing feeder. Each outgoing feeder can be fed by one or other of the busbars depending on where the circuit-breaker is positioned.

For example, source 1 feeds busbar BB1 and feeders Out1 and Out2. Source 2 feeds busbar BB2 and feeders Out3 and Out4. The bus coupler circuit-breaker can

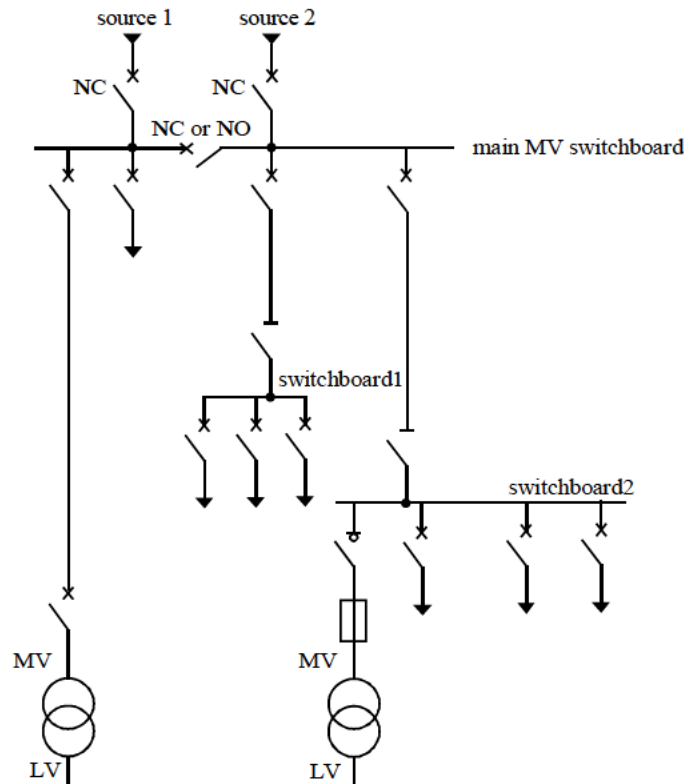
be kept closed or open during normal operation. If one source is lost, the other source provides the total power supply. If maintenance is carried out on one of the busbars, the coupler circuit-breaker is opened and each circuit-breaker is placed on the busbar in service, so that all the outgoing feeders are fed. If a fault occurs on a busbar, it is put out of service.

**1.5.2. MV network structures**

We shall now look at the main MV network structures used to feed secondary switchboards and MV/LV transformers. The complexity of the structures differs, depending on the level of power supply security required.

The following MV network supply arrangements are the ones most commonly adopted.

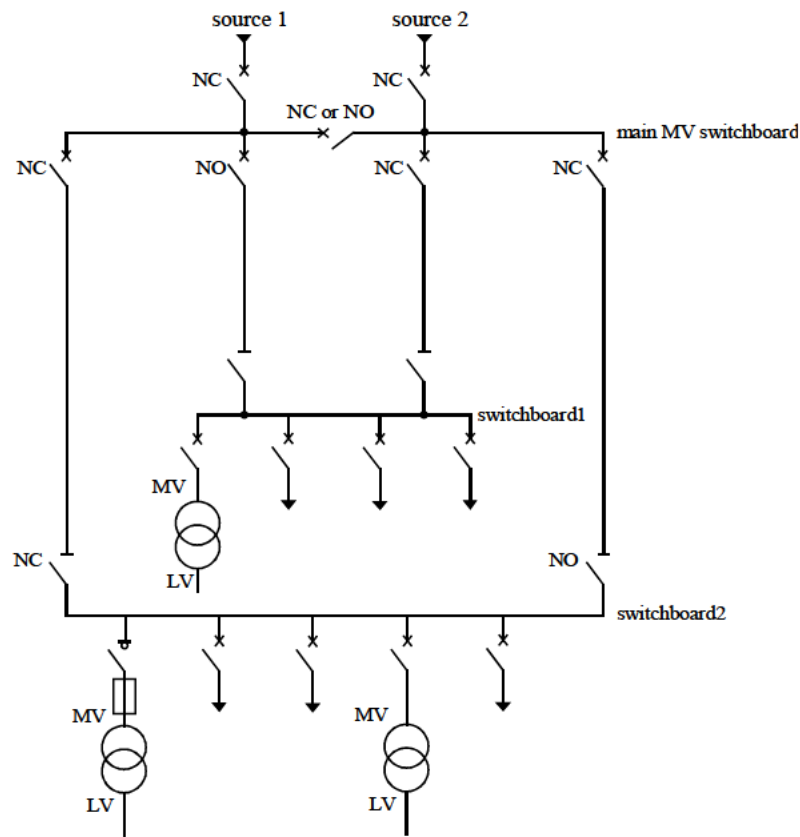
**Single fed radial network (see Figure 1-17)**



**Figure 1-17: MV single fed radial network**

- The main switchboard is fed by 2 sources with coupler.
- Switchboards 1 and 2 are fed by a single source, and there is no emergency back-up supply.
- This structure should be used when service continuity is not a vital requirement and it is often adopted for cement works networks.

**Dual fed radial network with no coupler (see Figure 1-18)**

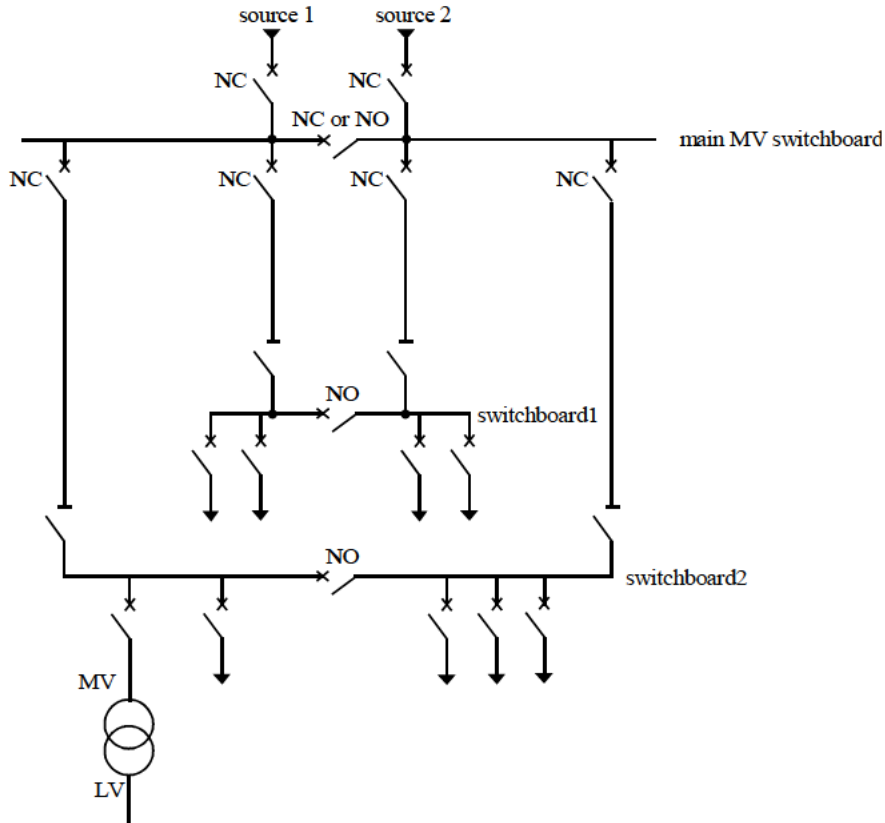


**Figure 1-18: MV dual fed radial network with no coupler**

- The main switchboard is fed by two sources with coupler.
- Switchboards 1 and 2 are fed by two sources with no coupler, the one backing up the other.
- Service continuity is good; the fact that there is no source coupler for switchboards 1 and 2 means that the network is less flexible to use.



**Dual fed radial network with coupler (see Figure 1-19)**



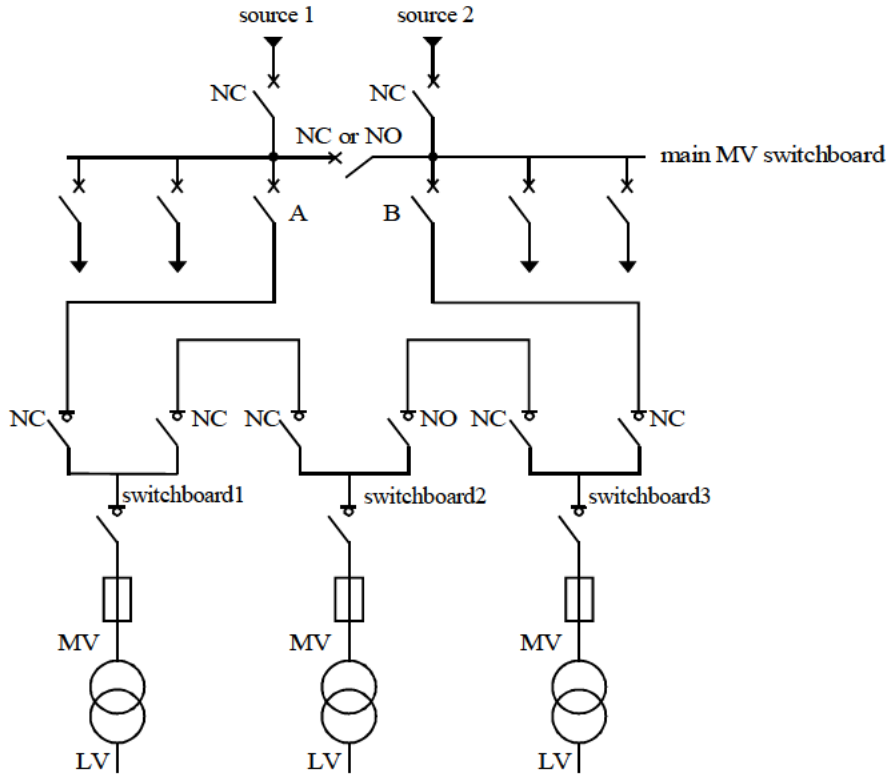
**Figure 1-19: MV dual fed radial network with coupler**

- The main switchboard is fed by two sources with coupler.
- Switchboards 1 and 2 are fed by 2 sources with coupler. During normal operation, the bus coupler circuit-breakers are open.
- Each bus section can be backed up and fed by one or other of the sources.
- This structure should be used when good service continuity is required and it is often adopted in the iron and steel and petrochemical industries.

**Loop system**

This system should be used for widespread networks with large future extensions. There are two types depending on whether the loop is open or closed during normal operation.

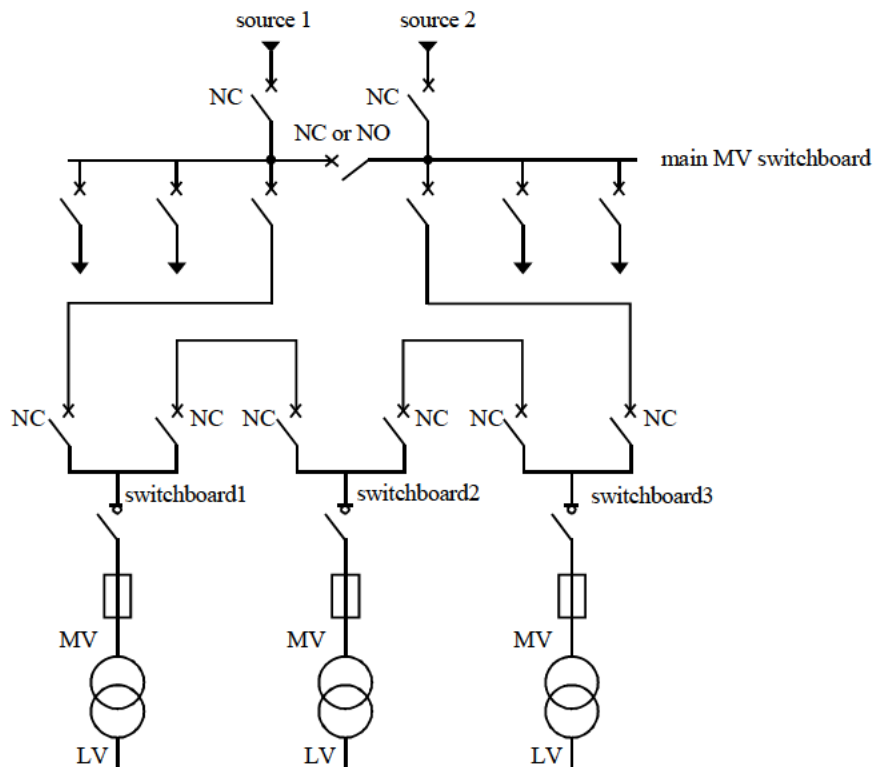
**Open loop (see Figure 1-20a)**



**Figure 1-20a: MV open loop system**

- The main switchboard is fed by two sources with coupler.
- The loop heads in A and B are fitted with circuit-breakers.
- Switchboards 1, 2 and 3 are fitted with switches.
- During normal operation, the loop is *open* (in the figure it is normally open at switchboard 2).
- The switchboards can be fed by one or other of the sources.
- Reconfiguration of the loop enables the supply to be restored upon occurrence of a fault or loss of a source (see section 10.1.7.1).
- This reconfiguration causes a power cut of several seconds if an automatic loop reconfiguration control has been installed. The cut lasts for at least several minutes or dozens of minutes if the loop reconfiguration is carried out manually by operators.

*Closed loop (see Figure 1-20b)*

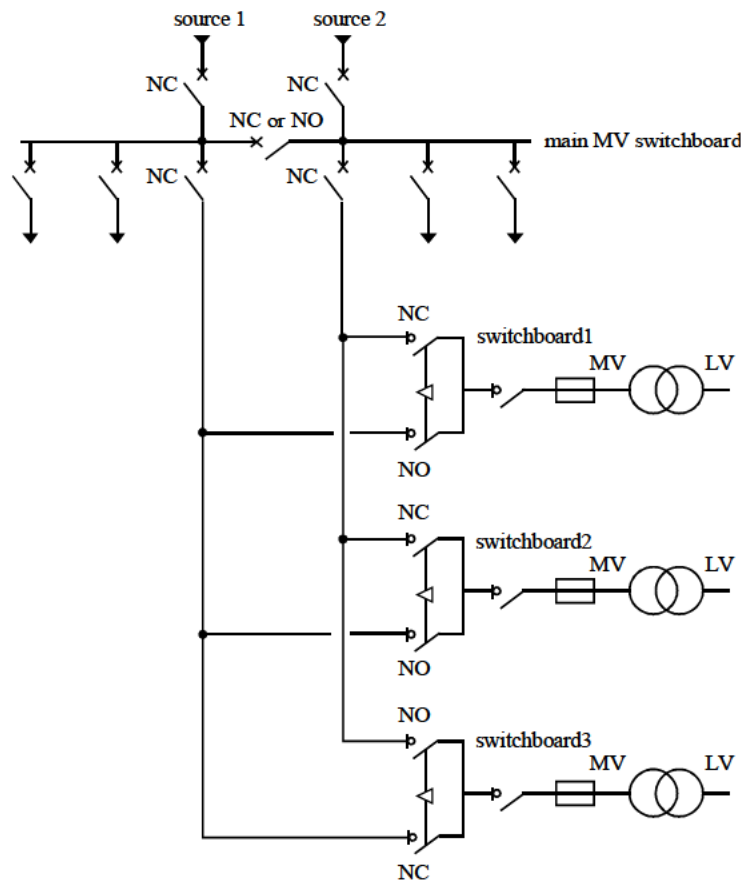


**Figure 1-20b:** *MV closed loop system*

- The main switchboard is fed by two sources with coupler.
- All the loop switching devices are circuit-breakers.
- During normal operation, the loop is closed.
- The protection system ensures against power cuts caused by a fault (see section 10.1.8).

This system is more efficient than the open loop system because it avoids power cuts. However, it is more costly since it requires circuit-breakers in each switchboard and a complex protection system.

*Parallel feeder (see Figure 1-21)*



**Figure 1-21:** *MV parallel feeder network*

- Switchboards 1, 2 and 3 can be backed up and fed by one or other of the sources independently.
- The main switchboard is fed by two sources with coupler.
- This structure should be used for widespread networks with limited future extensions and that require good supply continuity.

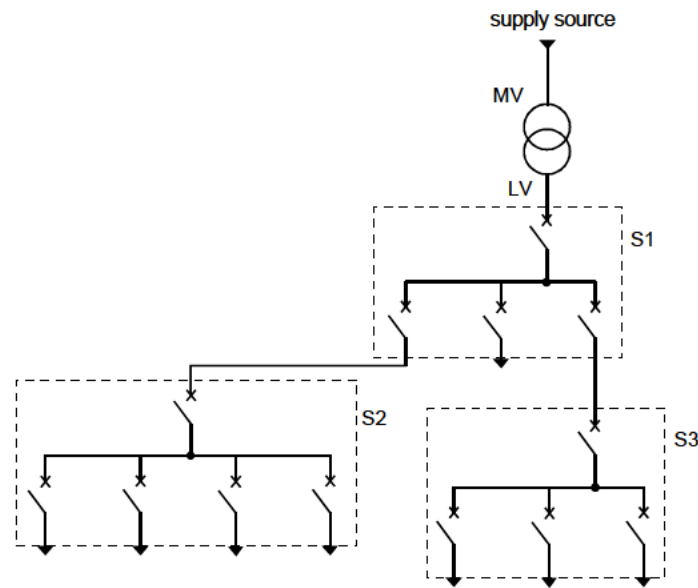
## 1.6. LV networks inside the site

We shall first of all study the different low voltage switchboard supply modes. Next, we shall look at the supply schemes for switchboards backed up by generators or an uninterruptible power supply.

### 1.6.1. LV switchboard supply modes

We are now going to study the main supply arrangements for an LV switchboard, regardless of its place in the network. The number of supply sources possible and the complexity of the switchboard differ according to the level of supply security required.

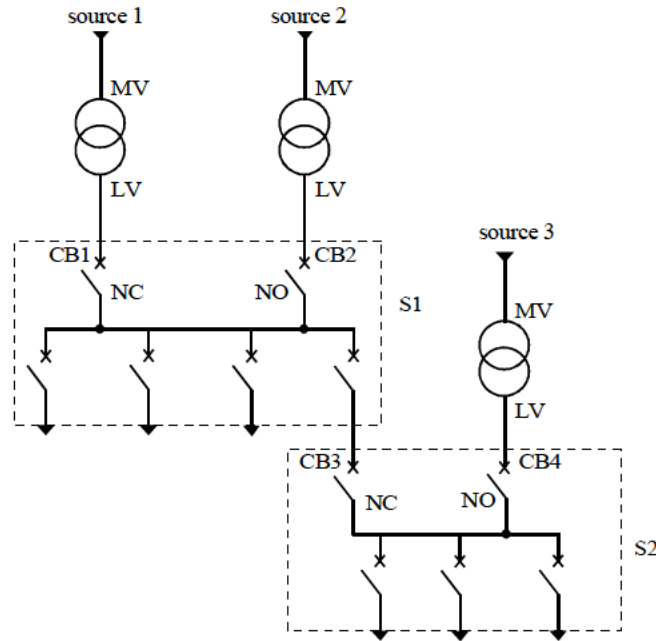
*Single fed LV switchboards (see Figure 1-22)*



**Figure 1-22:** *single fed LV switchboards*

Switchboards S1, S2 and S3 have only one supply source. The network is said to be of the *arborescent radial type*. If a switchboard supply source is lost, the switchboard is put out of service until the supply is restored.

**Dual fed LV switchboards with no coupler (see Figure 1-23)**



**Figure 1-23: dual fed LV switchboards with no coupler**

Switchboard S1 has a dual power supply with no coupler via two MV/LV transformers.

Operation of the S1 power supply:

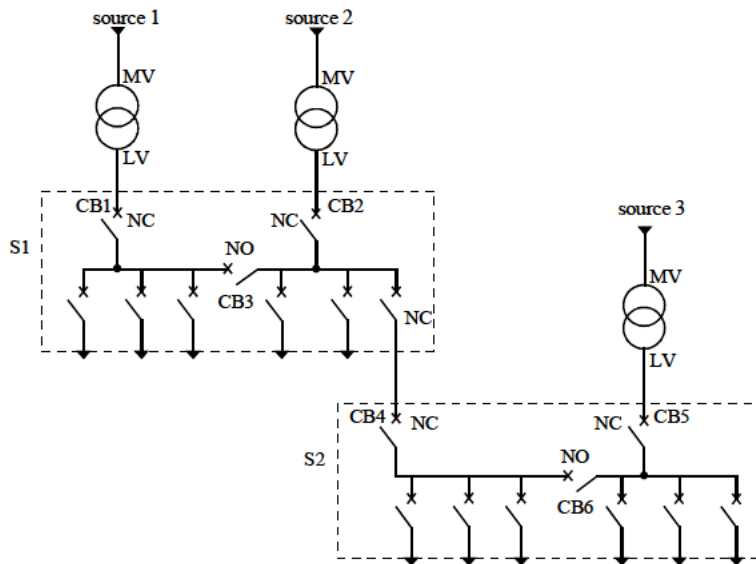
- one source feeds switchboard S1 and the second provides a back-up supply;
- during normal operation only one circuit-breaker is closed (CB1 or CB2).

Switchboard S2 has a dual power supply with no coupler via an MV/LV transformer and outgoing feeder coming from another LV switchboard.

Operation of the S2 power supply:

- one source feeds switchboard S2 and the second provides a back-up supply;
- during normal operation only one circuit-breaker is closed (CB3 or CB4).

**Dual fed LV switchboards with coupler (see Figure 1-24)**



**Figure 1-24: dual fed LV switchboards with coupler**

Switchboard S1 has a dual power supply with coupler via two MV/LV transformers.

Operation of the S1 power supply:

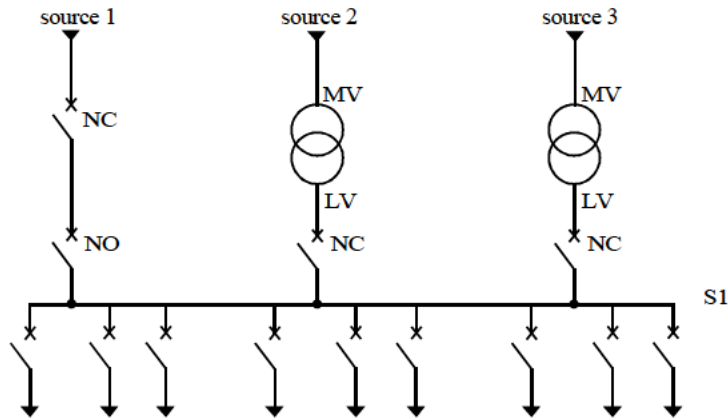
- during normal operation, the coupler circuit-breaker CB3 is open;
- each transformer feeds a part of S1;
- if a supply source is lost, the circuit-breaker CB3 is closed and a single transformer feeds all of S1.

Switchboard S2 has a dual power supply with coupler via an MV/LV transformer and an outgoing feeder coming from another LV switchboard.

Operation of the S2 power supply:

- during normal operation, the circuit-breaker CB6 is open;
- each source feeds part of S2;
- if a source is lost, the coupler circuit-breaker is closed and a single source feeds all of S2.

*Triple fed LV switchboards with no coupler (see Figure 1-25)*

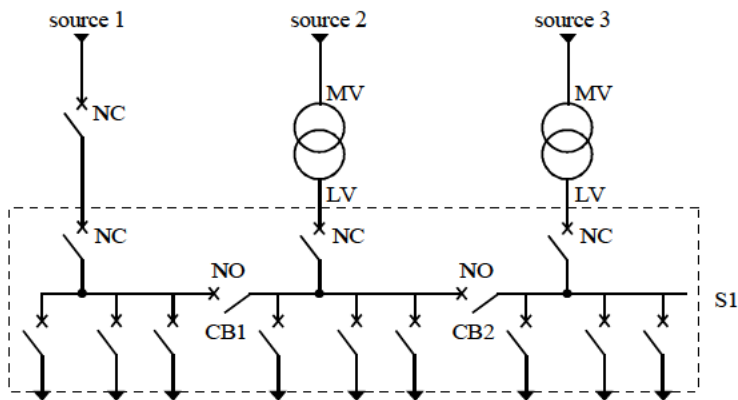


**Figure 1-25:** triple fed LV switchboards with no coupler

Switchboard S1 has a triple power supply with no coupler via two MV/LV transformers and an outgoing feeder coming from another LV switchboard.

During normal operation, the switchboard is fed by two transformers in parallel. If one or both of the transformers fail, switchboard S1 is fed by the outgoing feeder coming from another switchboard.

*Triple fed switchboards with coupler (see Figure 1-26)*



**Figure 1-26:** triple fed LV switchboards with coupler

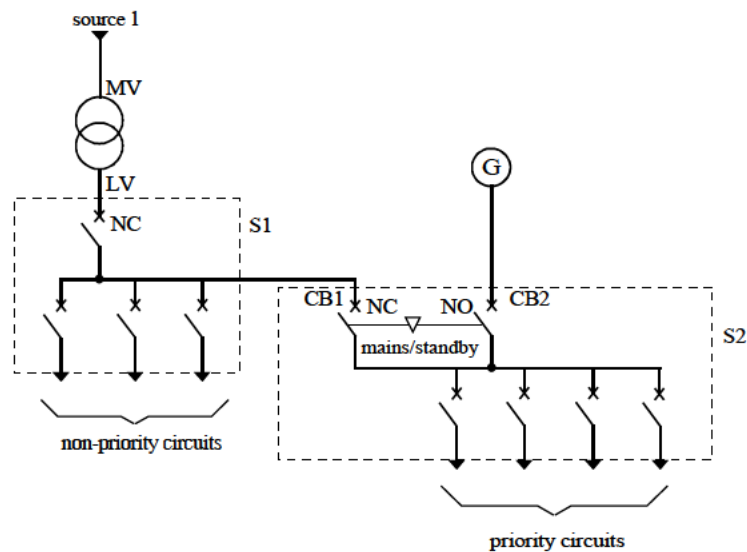
Switchboard S1 has a triple power supply with couplers via two MV/LV transformers and an outgoing feeder coming from another LV switchboard.



During normal operation, the two coupler circuit-breakers are open and switchboard S1 is fed by three supply sources. If one source fails, the coupler circuit-breaker of the associated source is closed and the incoming circuit-breaker of the source that has been lost is opened.

### 1.6.2. LV switchboards backed up by generators

*Example 1: 1 transformer and 1 generator (see Figure 1-27)*



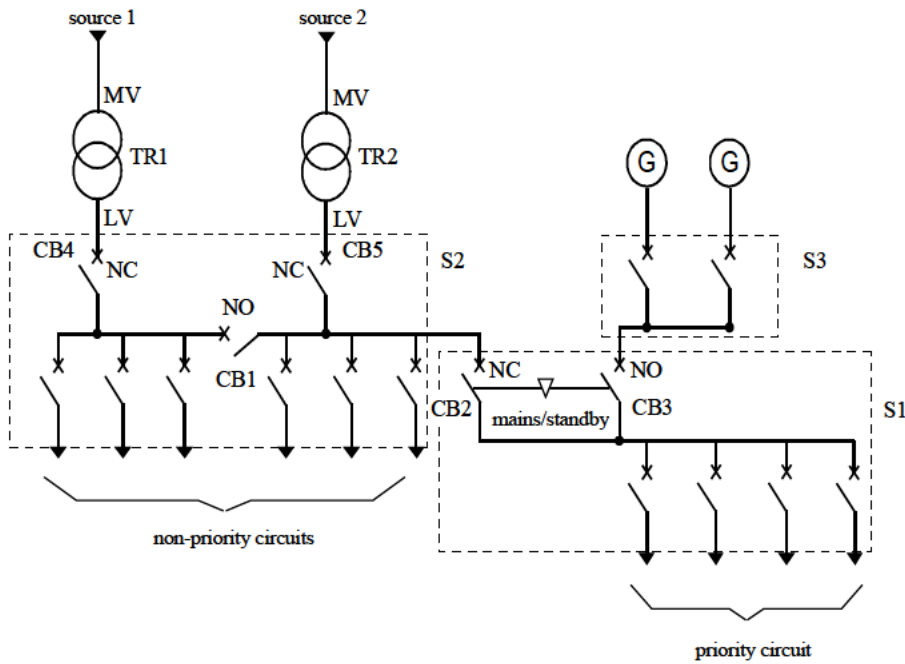
**Figure 1-27:** 1 transformer and 1 generator

During normal operation CB1 is closed and CB2 is open. Switchboard S2 is fed by the transformer. If the main source is lost, the following steps are carried out:

1. The mains/standby changeover switch is operated and CB1 is tripped.
2. Load shedding, if necessary, of part of the loads on the priority circuit in order to facilitate start-up of the generator.
3. Start-up of the generator.
4. CB2 is closed when the frequency and voltage of the generator are within the required ranges.
5. Reloading of loads which may have been shed during step 2.

Once the main source has been restored, the generator is stopped and the mains/standby changeover device switches the S2 supply to the mains.

**Example 2: 2 transformers and 2 generators (see Figure 1-28)**



**Figure 1-28: 2 transformers and 2 generators**

During normal operation, the coupler circuit-breaker CB1 is open and the mains/standby changeover device is in position CB2 closed and CB3 open. Switchboard S1 is fed by transformer TR2.

If source 2 is lost or there is a breakdown on TR2, the S1 (and part of S2) standby supply is given priority by transformer TR1, after reclosing of the coupler circuit-breaker CB1. The generators are only started up after the loss of the two main supply sources. The steps for saving the priority circuit supply are carried out in the same way as in example 1.

**1.6.3. LV switchboards backed up by an uninterruptible power supply (UPS)**

The main devices that make up a UPS system are shown in Figure 1-29 and Table 1-1.

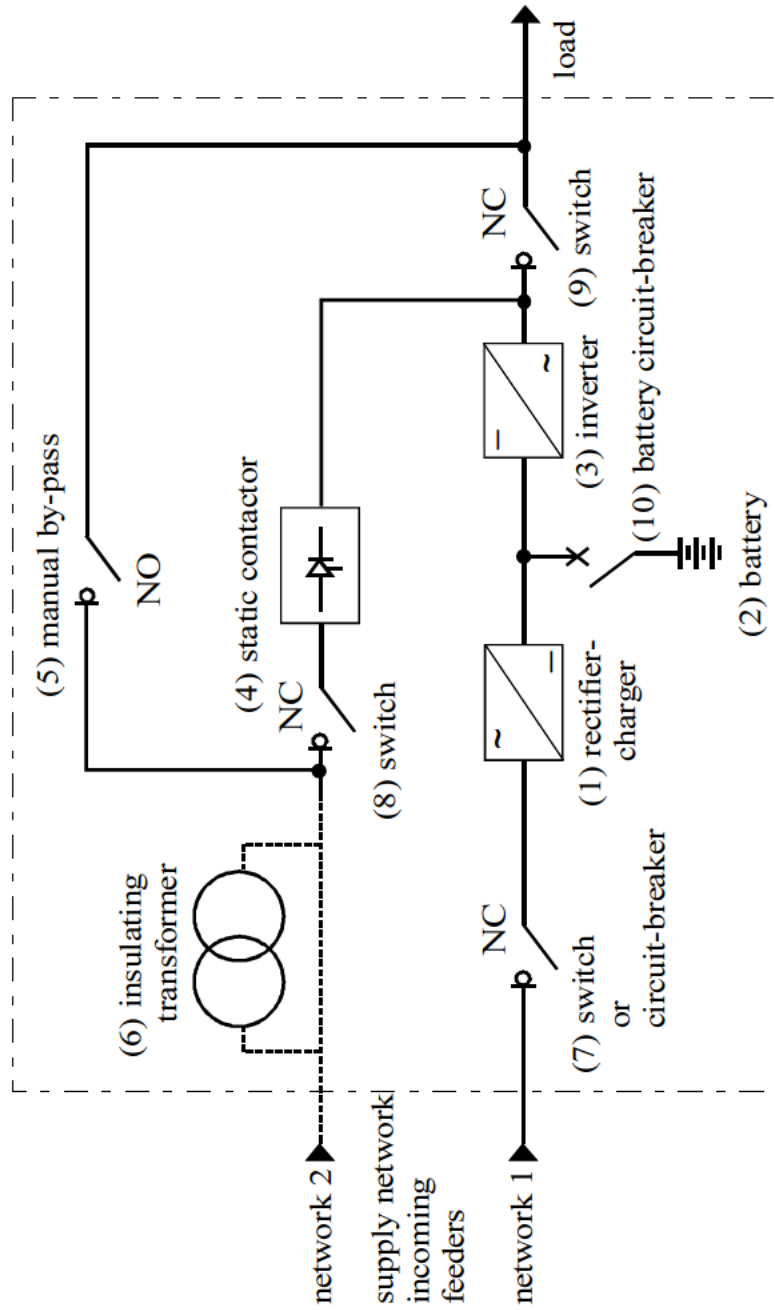


Figure 1-29: UPS system

Device name	Ref. no	Function
Rectifier-charger	(1)	Transforms the alternating voltage of a supply network into a direct voltage which will: <ul style="list-style-type: none"> <li>– feed the inverter;</li> <li>– continually provide the charge for the storage battery.</li> </ul>
Storage battery	(2)	Provides a back-up supply to feed the inverter in case: <ul style="list-style-type: none"> <li>– the supply network disappears (power cut);</li> <li>– the supply network is disturbed (disturbances leading to insufficient quality).</li> </ul>
Inverter	(3)	Transforms the direct voltage from the rectifier-charger or storage battery into three-phase alternating voltage with more severe tolerances than those of the network (supplies an alternating current close to the theoretical sine curve).
Static contactor	(4)	Switches over the load supply from the inverter to network 2 (standby) without interruption (no cut due to mechanical switching device changeover time – the switchover is carried out using electronic components in a time < 1 ms). This switchover is performed if the inverter stops working for one of the following reasons: <ul style="list-style-type: none"> <li>– switched off;</li> <li>– overload beyond the limiting capacities of the inverter;</li> <li>– internal anomaly.</li> </ul>
Manual by-pass	(5)	Manual switch which allows the user to be fed by network 2 (standby), while maintenance is being carried out. Its presence is indispensable when the network frequencies upstream and downstream of the UPS are identical.
Insulating transformer	(6)	Provides upstream and downstream insulation when the supply is via network 2. It is especially used when the upstream and downstream earthing systems are different.
Manual switches Battery circuit-breakers	(7) (8) (9) (10)	Provides insulation of the different parts when maintenance is being carried out.

**Table 1-1:** *function of different devices making up a UPS system*

*Network incoming feeder(s)*

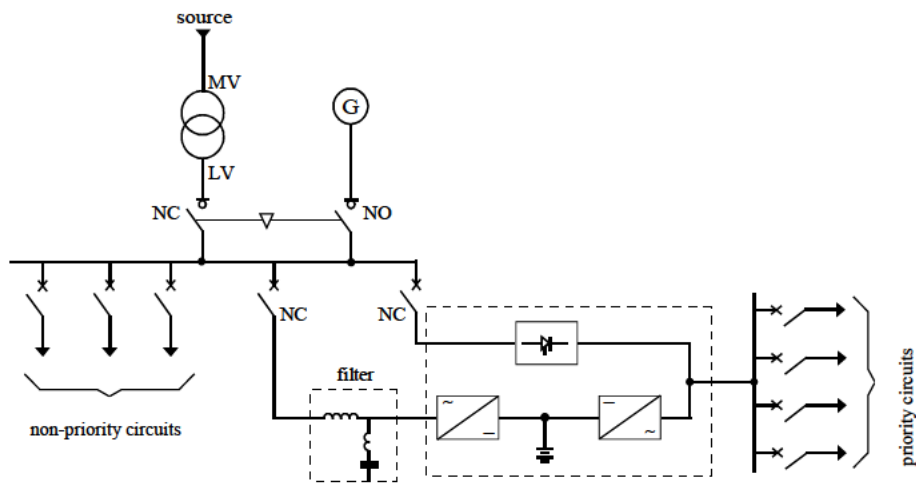
The terms network 1 and network 2 designate two independent incoming feeders on the same network:

- network 1 (or mains) designates the incoming feeder usually supplying the rectifier-charger;
- network 2 (or standby) is said to be a back-up feeder.

The inverter's frequency is synchronized with network 2, thereby allowing the load to be instantaneously fed by network 1 (in a time < 1 ms) via the static contactor.

The connection of a UPS system to a second independent network is recommended since it increases the reliability of the system. It is nevertheless possible to have only one common incoming feeder.

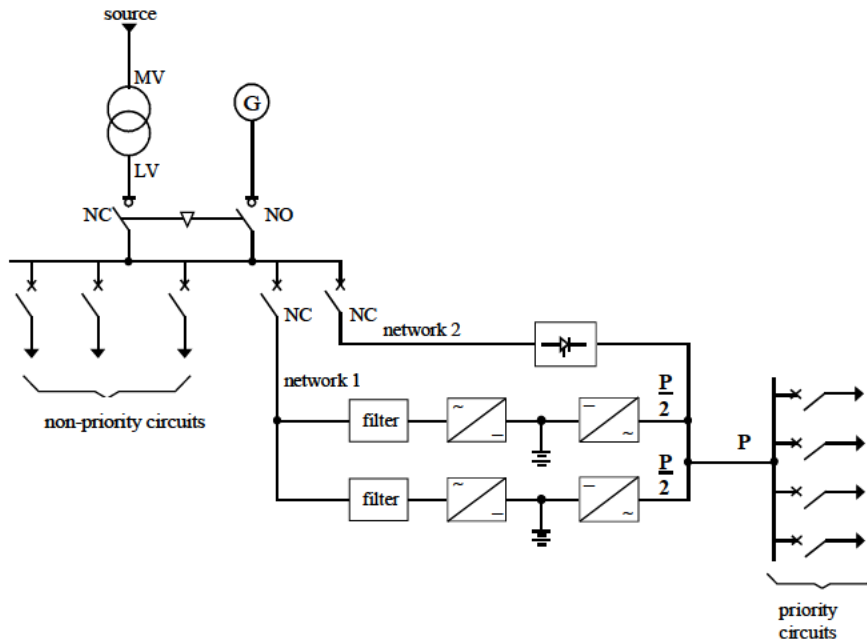
**Example 1: LV switchboard backed up by an inverter, with a generator to eliminate the problem of the limited autonomy of the battery (usually about 15 mn) (see Figure 1-30)**



**Figure 1-30: LV switchboard backed up by an inverter**

The filter allows harmonic currents traveling up the supply network to be reduced.

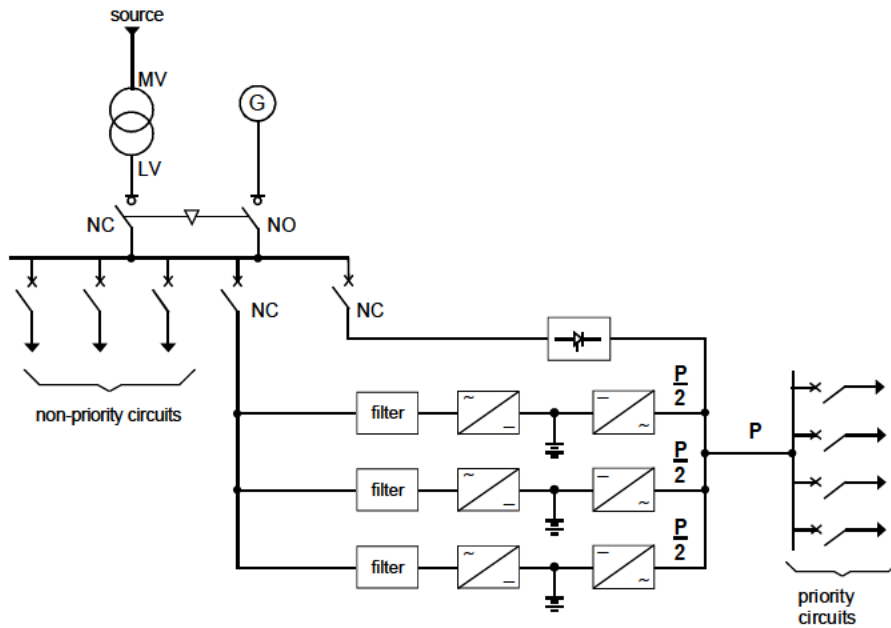
**Example 2: LV switchboard backed up by 2 inverters in parallel with no redundancy (see Figure 1-31)**



**Figure 1-31: LV switchboard backed up by 2 inverters in parallel with no redundancy**

This configuration only allows an overall power capacity above that of a single rectifier/inverter unit. The power  $P$  to be supplied is also divided between the two inverters. A fault in one of the units leads to the load being switched to network 2 without interruption, except when the network is beyond its tolerance level.

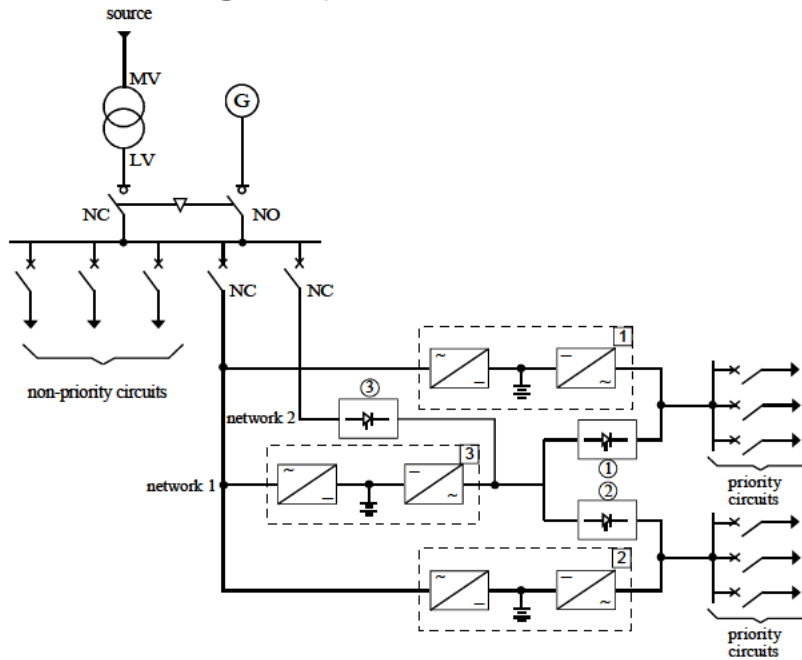
**Example 3: LV switchboard backed up by 3 inverters, one of which is actively redundant (see Figure 1-32)**



**Figure 1-32: LV switchboard backed up by 3 inverters, one of which is actively redundant**

Let  $P$  be the maximum load rating of the priority circuit. Each inverter has a rated power of  $\frac{P}{2}$ , which means that when one inverter breaks down, the other two inverters provide the total load power supply. This is referred to as a *parallel-connected unit with 1/3 active redundancy*.

**Example 4: LV switchboard backed up by 3 inverters, one of which is on standby redundancy (see Figure 1-33)**



**Figure 1-33: LV switchboard backed up by 3 inverters, one of which is on standby redundancy**

Inverter ③ is not charged; it is on standby ready to back up inverter ① or ②. There is no power cut during switchover due to static contactors ① and ②. Static contactor ③ provides back-up via network 2 in case there is a failure on network 1, or the two inverters break down. This is referred to as a *parallel-connected unit with standby redundancy*.

### 1.7. Industrial networks with internal generation

**Example (see Figure 1-34)**

Network structure:

- MV consumer substation;
- the main MV switchboard is fed by the internal generating station;
- some MV outgoing feeders are fed by the utility and cannot be backed up by the internal generating station;
- an MV loop system and some outgoing feeders are fed during normal operation by the internal generating station. If the generating station breaks down, this loop system and its outgoing feeders can be fed by the utility.



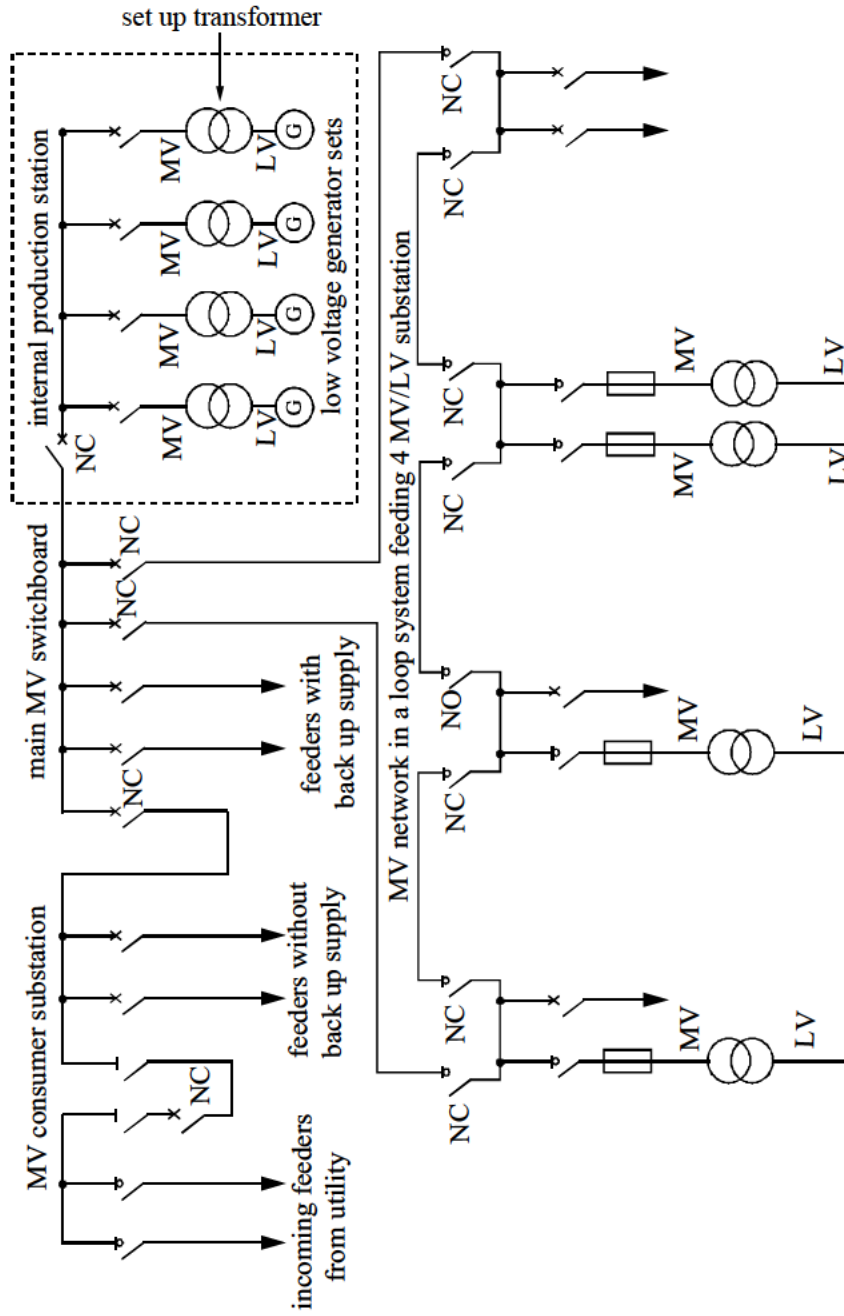


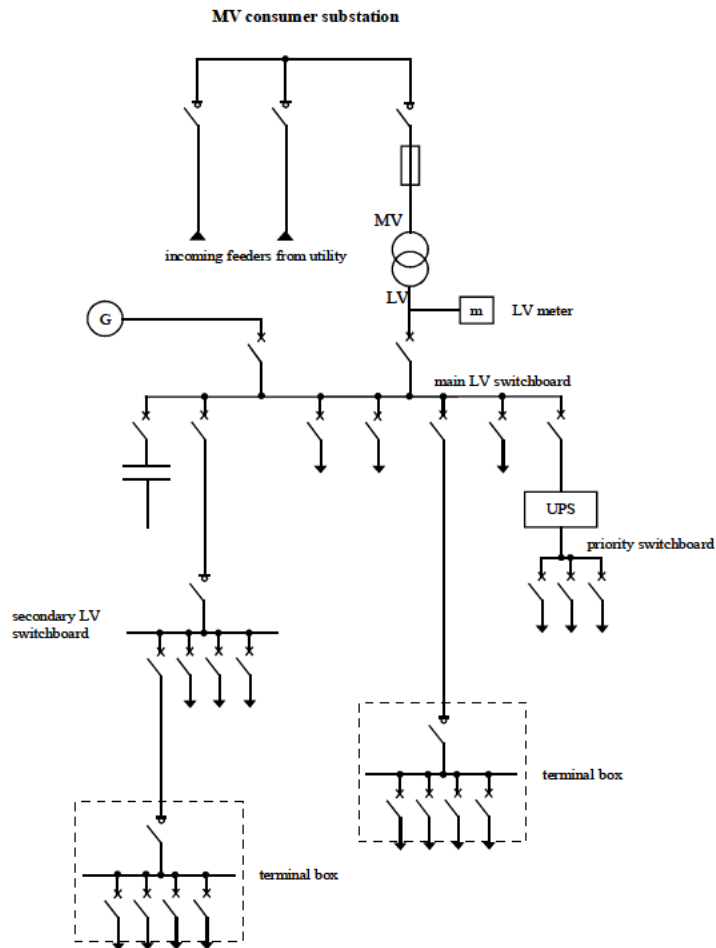
Figure 1-34: industrial network with internal generation

**1.8. Examples of standard networks**

*Example 1 (see Figure 1-35)*

Network structure:

- MV consumer substation in a ring main system with two incoming feeders;
- main low voltage switchboard backed up by a generator;
- a priority switchboard fed by a UPS;
- the low voltage network is of the arborescent radial type, and the secondary switchboard and terminal boxes are fed by a single source.



**Figure 1-35: example 1**

**Example 2 (see Figure 1-36)**

Network structure:

- MV consumer substation;
- the main MV switchboard can be backed up by a generator set and feeds three transformers;
- the main low voltage switchboards MLVS1, MLVS2 and MLVS3 are independent and each one has an outgoing feeder to an uninterruptible power supply feeding a priority circuit;
- the low voltage network is of the arborescent radial type, and the motor control centers and terminal boxes are fed by a single source.

**Example 3 (see Figure 1-37)**

Network structure:

- MV consumer substation;
- the main MV switchboard can be backed up by a generator set and it feeds two MV/LV transformers;
- the main low voltage switchboard has a dual power supply with coupler;
- each bus section of the main low voltage switchboard has a UPS system feeding a priority circuit;
- the secondary switchboards, terminal boxes and motor control centers are fed by a single source.

**Example 4 (see Figure 1-38)**

Network structure:

- MV consumer substation;
- the main MV switchboard can be backed up by a generator set. It feeds two MV/LV transformers in a single line supply system, four MV secondary switchboards in a loop system, and a secondary MV switchboard in a single line supply system;
- the low voltage network is of the *arborescent radial type*.

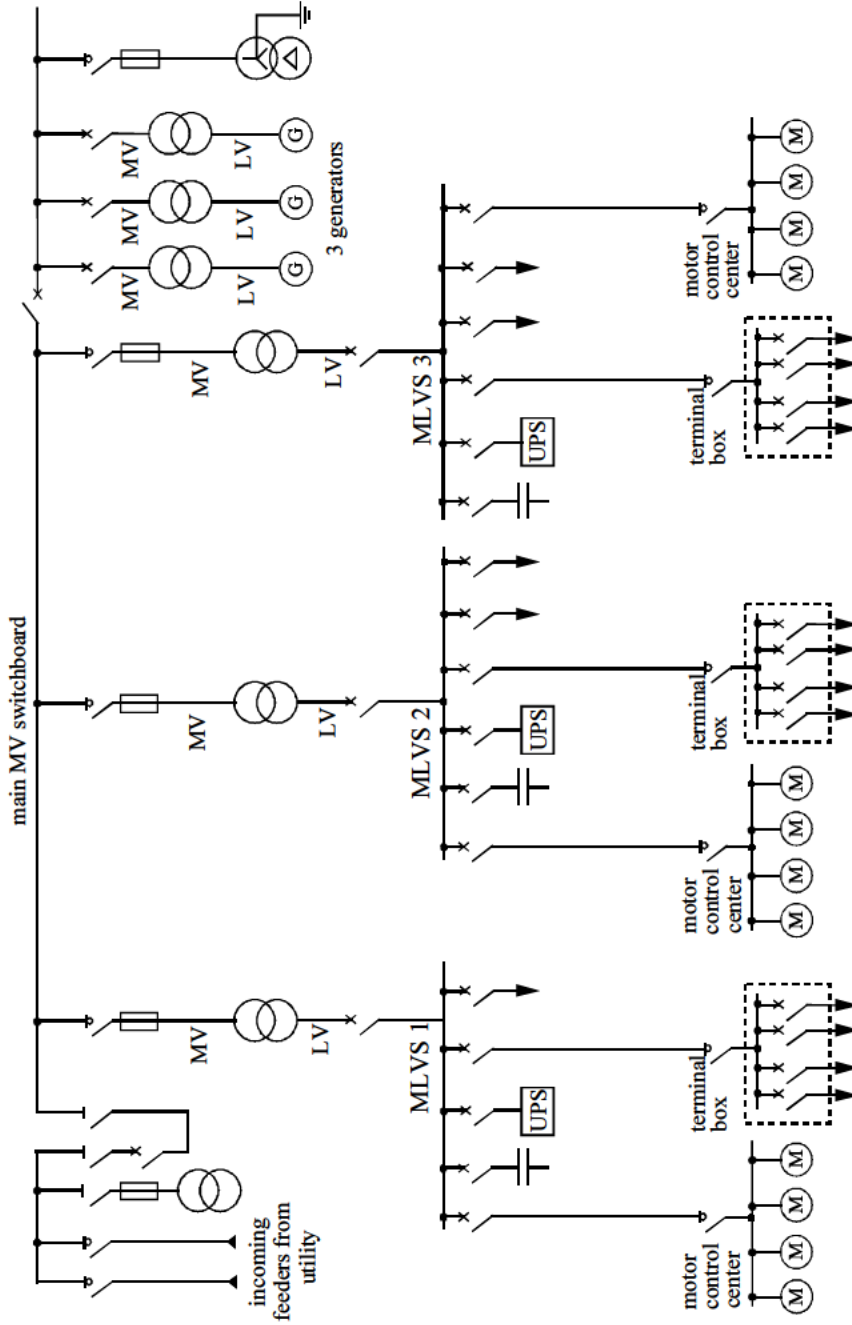


Figure 1-36: example 2

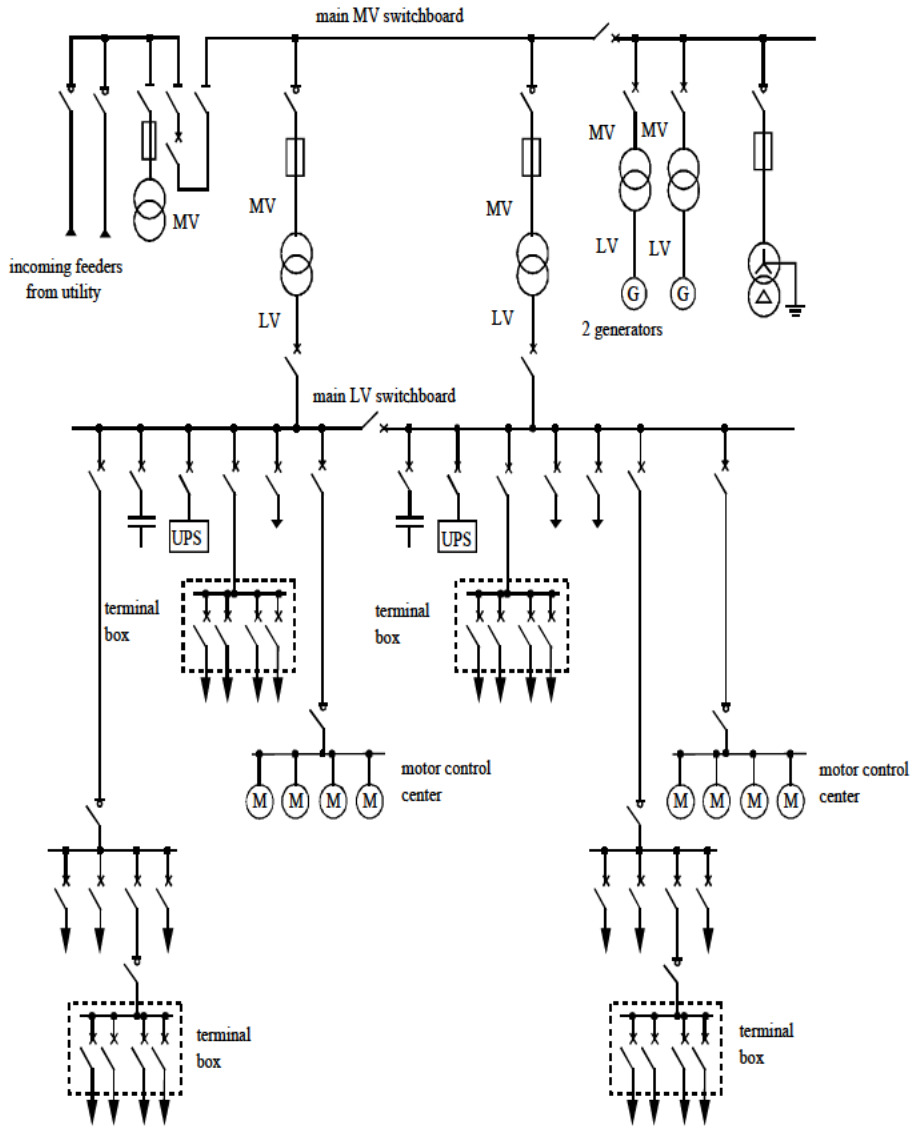


Figure 1-37: example 3: dual fed switchboard with 2/3 type transfer

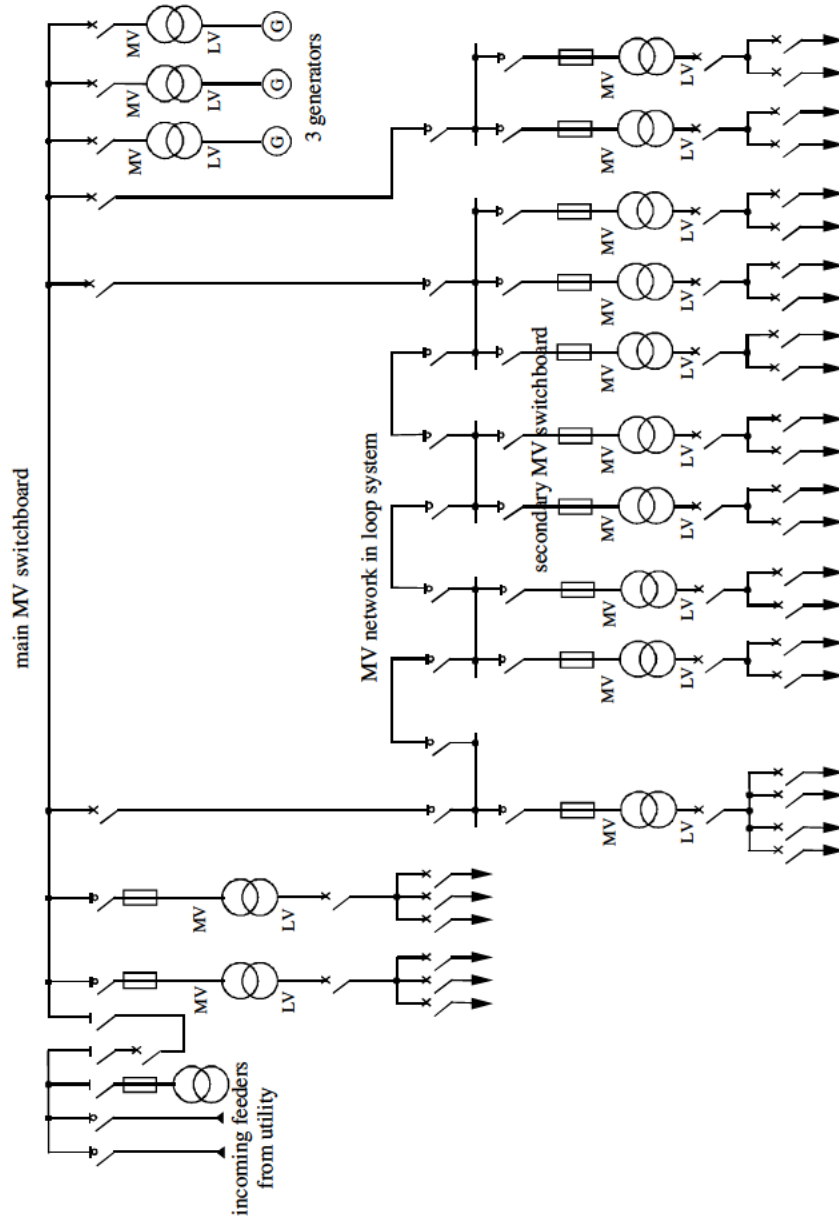


Figure 1-38: example 4

**Example 5 (see Figure 1-39)**

Network structure:

- MV consumer substation;
- two MV ratings: 20 kV and 6 kV;
- the main MV switchboard fed at 20 kV can be backed up by a set of four generators. It feeds:
  - an MV 20 kV network in a loop system comprising three secondary switchboards MV4, MV5 and MV6;
  - two 20 kV/6kV transformers in a single line supply system;
- the MV main switchboard is made up two bus sections fed at 6 kV by two sources with coupler;
  - it feeds three MV secondary switchboards and two 6 kV/LV transformers in a single line supply system;
  - the secondary switchboard MV2 is fed by two sources with coupler and is made up of two bus sections. It feeds two 6 kV motors and two 6 kV/LV transformers in a single line supply system;
  - the secondary switchboards MV1 and MV3 are fed by a single source. Each feeds a 6 kV/LV transformer and a 6 kV motor;
  - the main low voltage switchboard MLVS1 can be backed up by a generator;
  - the main low voltage switchboard MLVS2 is fed by two sources with coupler;
  - the main low voltage switchboard MLVS3 is fed by a single source;
  - the motor control centers 1 and 3 are fed by a single source;
  - the motor control center 2 is fed by 2 sources with no coupler.

**Example 6 (see Figure 1-40)**

Network structure:

- HV consumer substation fed at 90 kV by two HV sources with no coupler (isolators ISO1 and ISO2 cannot operate when loaded and are in closed position during normal operation);
- the central HV/MV transformer is used as back-up. The transformers can be connected on the MV side via the circuit-breakers (moreover, the on-load tap changers allow the currents supplied by each transformer to be balanced);
- the network has two MV ratings: 20 kV and 6 kV;
- the main MV switchboard is fed at 20 kV by three sources with coupler. It is made up of three bus sections;
- the secondary switchboards MV1, MV2 and MV3 are fed at 6 kV by two sources (transformers) with coupler coming from two different busbars;

- the main low voltage switchboards MLVS1, MLVS2, MLVS3 and MLVS4 are fed by two sources with coupler;
- the motor control centers 1, 2, 3 and 4 are fed by two sources with no coupler.

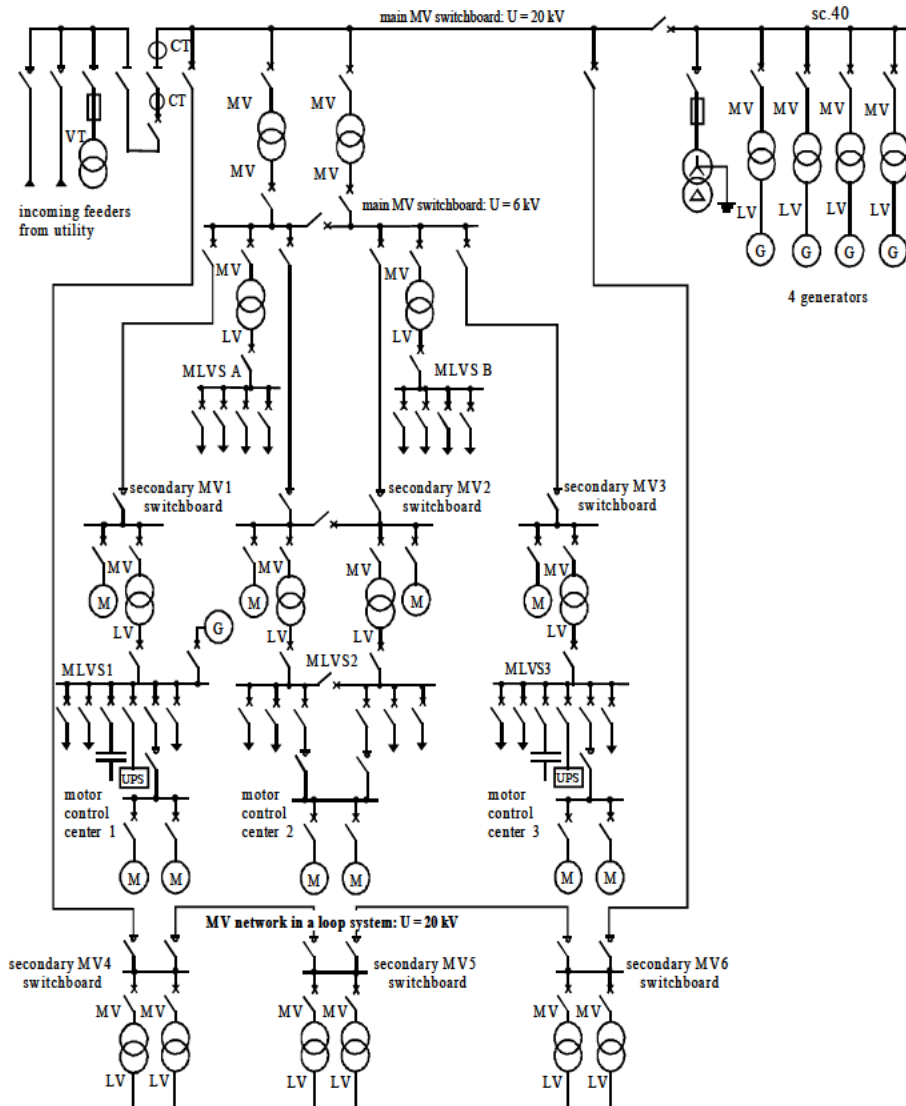


Figure 1-39: example 5



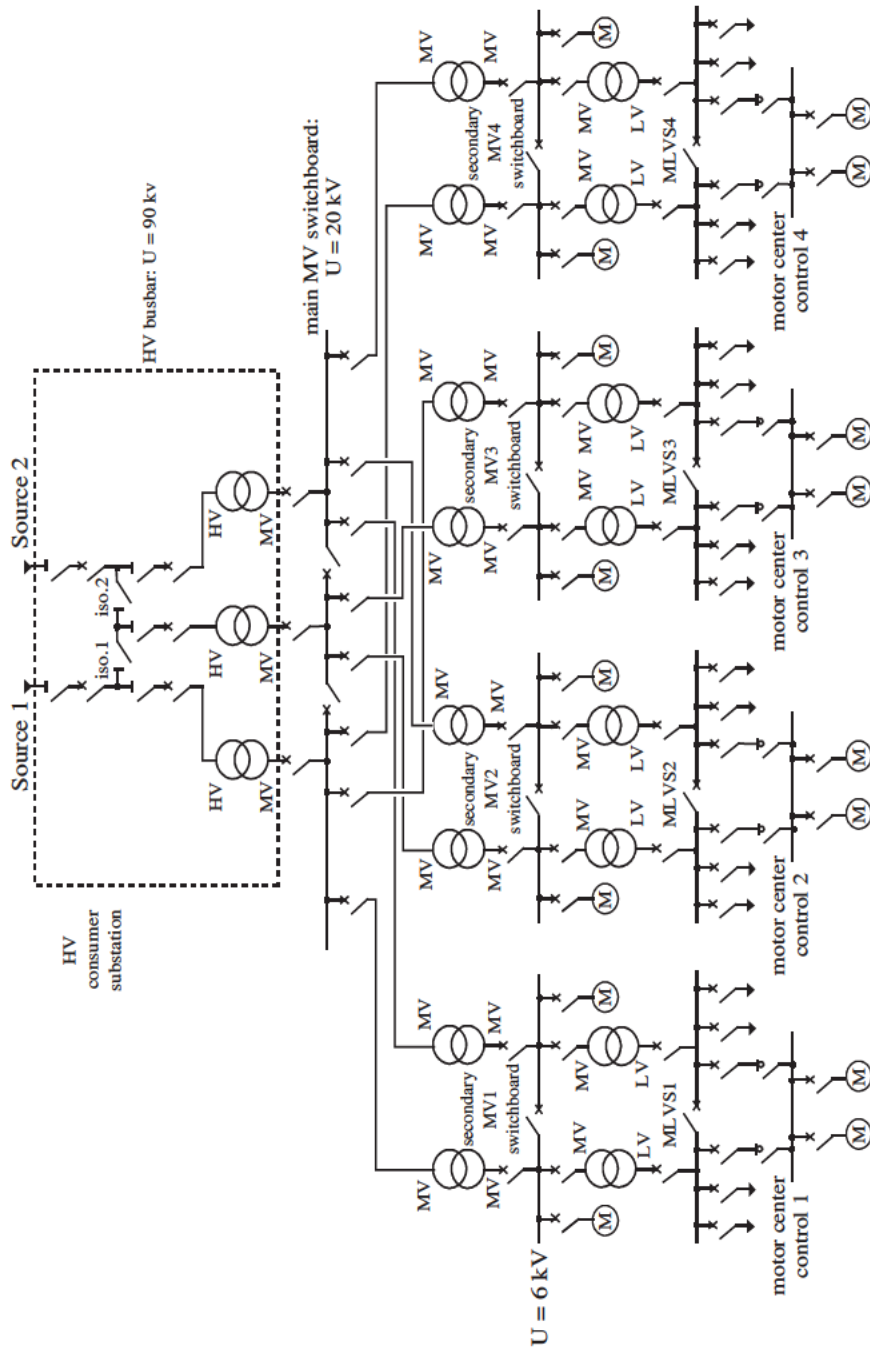


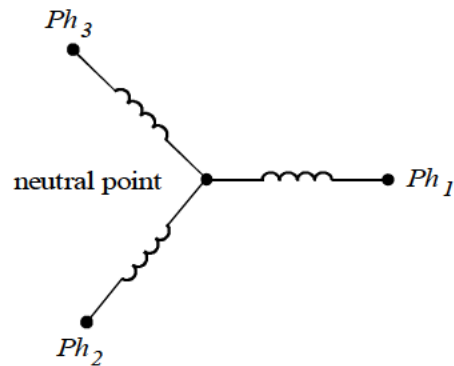
Figure 1-40: example 6

## Chapter 2

# Earthing Systems

In any medium or low voltage three-phase system there are three single voltages measured between each phase and a common point called the “neutral point”.

In actual fact, the neutral is the common point of three star-connected windings (see Figure 2-1).



**Figure 2-1:** neutral point of a three-phase star system

The neutral may or may not be accessible or distributed. Except in specific cases (e.g. networks in North America and Australia), the neutral is not distributed at medium voltage. However, the neutral is very often distributed at low voltage.

In a medium or low voltage installation, the neutral may or may not be earthed. This is why we talk about the *earthing system*.

The neutral may be directly connected to earth or connected through a resistor or a reactor. In the first case, we say that the neutral is *directly earthed* and in the second case we say that it is *impedance-earthed*.

When a connection has not been made between the neutral point and earth, we say that the neutral is *unearthed*.

In a network, the earthing system plays a very important role. When an insulation fault occurs or a phase is accidentally earthed, the values taken by the fault currents, the touch voltages and overvoltages are closely linked to the type of neutral earthing connection.

A directly earthed neutral strongly limits overvoltages but it causes very high fault currents, whereas an unearthed neutral limits fault currents to very low values but encourages the occurrence of high overvoltages.

In any installation, service continuity in the event of an insulation fault is also directly related to the earthing system. An unearthed neutral permits service continuity during an insulation fault. Contrary to this, a directly earthed neutral, or low impedance-earthed neutral, causes tripping as soon as the first insulation fault occurs.

The extent of the damage to some equipment, such as motors and generators presenting an internal insulation fault, also depends on the earthing system.

In an earthed network, a machine affected by an insulation fault suffers extensive damage due to the large fault currents.

However, in an unearthed or high impedance-earthed network, the damage is reduced, but the equipment must have an insulation level compatible with the level of overvoltages able to cope in this type of network.

The choice of earthing system in both low voltage and medium voltage networks depends on the type of installation as well as the type of network. It is also influenced by the type of loads and service continuity required.

### **2.1. Earthing systems at low voltage**

We shall first of all define the different low voltage earthing systems and then compare the advantages and disadvantages of each one.

### 2.1.1. Different earthing systems – definition and arrangements

Earthing systems are governed by standard IEC 60364-3. There are three types of systems: IT, TT and TN.

The first letter defines the neutral point in relation to earth:

- T directly earthed neutral
- I unearthed or high impedance-earthed neutral (e.g. 2,000  $\Omega$ )

The second letter defines the exposed conductive parts of the electrical installation in relation to earth:

- T directly earthed exposed conductive parts
- N exposed conductive parts directly connected to the neutral conductor

#### *IT system unearthed or impedance-earthed neutral (see Figure 2-2)*

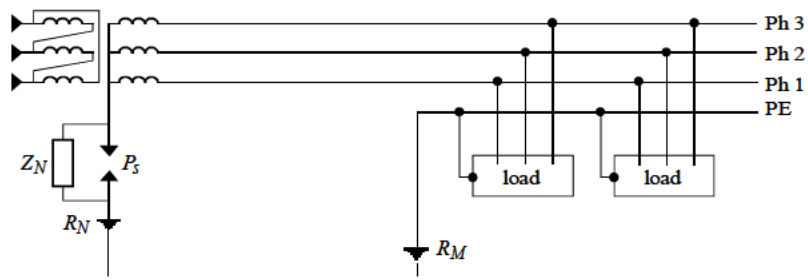
##### *Letter I*

The neutral is unearthed or connected to earth by a high impedance (an impedance of 1,700  $\Omega$  is often used).

##### *Letter T*

The exposed conductive parts of the loads are interconnected and earthed.

A group of loads can be individually earthed if it is situated far away from the other loads.



$Z_N$ : neutral earthing impedance

$P_3$ : overvoltage limiter

**Figure 2-2:** unearthed or impedance-earthed neutral (IT system) in low voltage system

Specific characteristics:

- Switching upon occurrence of a double fault is usually generated by phase-to-phase fault protective devices (circuit-breakers, fuses, etc.).
- If the short-circuit current is not large enough to activate protection against phase-to-phase faults, notably if the loads are far away, protection should be ensured by residual current devices (RCDs).
- It is not advisable to distribute the neutral (see section 4.4.1.3).
- It is compulsory to install an overvoltage limiter between the MV/LV transformer neutral point and earth. If the neutral is not accessible, the overvoltage limiter is installed between a phase and earth. It runs off external overvoltages, transmitted by the transformer, to the earth and protects the low voltage network from a voltage increase due to flashover between the transformer’s medium voltage and low voltage windings.
- A group of individually earthed loads must be protected by an RCD.

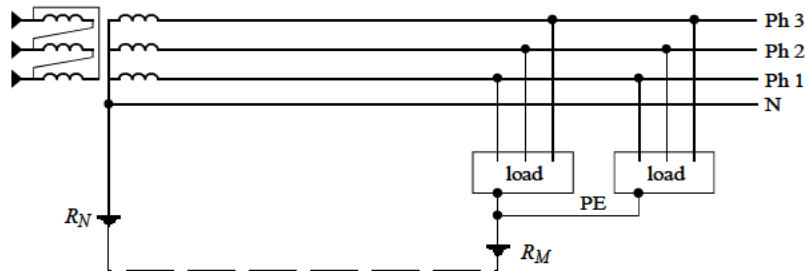
***TT system directly earthed neutral (see Figure 2-3)***

*First letter T*

The neutral is directly earthed.

*Second letter T*

The exposed conductive parts of the loads are interconnected either altogether or by a group of loads. Each interconnected group is earthed. One exposed conductive part can be individually earthed if it is far away from the others.



**Figure 2-3:** *directly earthed neutral (TT system) in low voltage*

Specific characteristics:

- The installation of RCDs is compulsory.
- All exposed conductive parts protected by the same protective device should be connected to the same earth.
- The neutral earth and the exposed conductive part earth may or may not be interconnected or combined.
- The neutral may or may not be distributed.

***TN system neutral-connected exposed conductive part***

*Letter T*

The neutral is directly earthed.

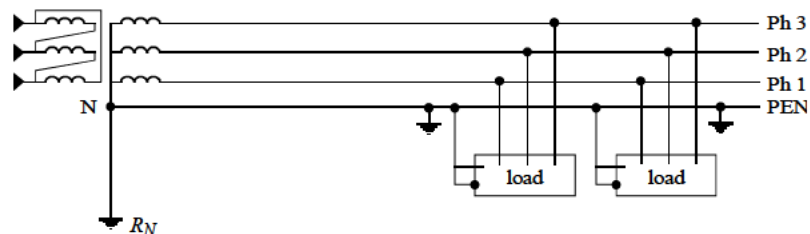
*Letter N*

The exposed conductive parts of the loads are connected to the neutral conductor.

There are two types of systems, possibly depending on whether the neutral conductor and protective conductor (PE) are combined or not:

- *Case 1:* The neutral and protective conductors are combined in a single conductor called PEN. The system is identified by a third letter C and is called TNC (see Figure 2-4). Earthing connections must be evenly placed along the length of the PEN conductor to avoid potential rises in the exposed conductive parts if a fault occurs. This system must not be used for copper cross-sections of less than 10 mm<sup>2</sup> and aluminium cross-sections of less than 16 mm<sup>2</sup>, as well as downstream of a TNS system (see IEC 60364-5, section 546-2). Nor must it be used for moveable trunkings (see IEC 60364-4, section 413.1.3.2).

- *Case 2:* The neutral conductor and protective conductor are separate. The system is identified by a third letter S and is called TNS (see Figure 2-5). Earthing connections must be evenly placed along the length of the protection conductor PE to avoid potential rises in the exposed conductive parts if a fault occurs. This system must not be used upstream of a TNC system.



**Figure 2-4:** TNC system

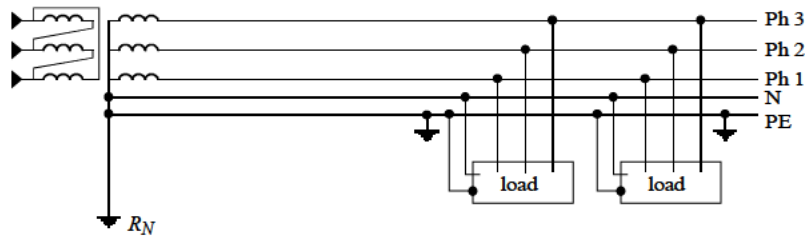


Figure 2-5: TNS system

Specific characteristics of TNS and TNC systems:

- Fault switching is obtained by devices providing protection against phase-to-phase faults (circuit-breakers, fuses, etc.).

Note: both TNS and TNC systems can be used in the same installation. The TNC system (4 wires), however, must never be downstream of the TNS system (5 wires).

### 2.1.2. Comparison of different earthing systems in low voltage

The three earthing systems are different in the way they operate and afford protection. Each has its advantages and disadvantages which we shall now consider.

#### 2.1.2.1. Unearthed or impedance-earthed neutral (IT system) (see Figure 2-2)

Operating technique:

- Permanent insulation monitoring.
- First insulation fault indication.
- Compulsory fault location and clearance.
- Switching if two insulation faults occur at the same time (double fault).

Technique for protecting persons:

- Interconnection and earthing of exposed conductive parts.
- First fault monitoring by a permanent insulation monitor (see section 2.4.1).
- Switching upon occurrence of the second fault by overcurrent protective devices (circuit-breakers or fuses).

Advantages:

- System providing the best service continuity during use.
- When an insulation fault occurs, the short-circuit current is very low.

## Disadvantages:

- Requires maintenance personnel to monitor the system during use.
- Requires a good level of network insulation (which means that the network must be broken up if widespread, and that loads with high leakage current must be supplied by insulating transformers).
- Tripping checks for two simultaneous faults should be carried out if possible when the network is being designed using calculation, and must be performed during commissioning using measurement.
- Overvoltage limiters must be installed.
- Requires all the installation's exposed conductive parts to be equipotentially bonded; if this is not possible RCDs must be installed.
- Avoid distributing the neutral conductor. In the IT system, it is in fact recommended not to distribute the neutral for the following reasons:
  - if the neutral conductor is distributed, a fault affecting it will eliminate the advantages attached to the IT system;
  - if the neutral is distributed, it must be protected (except for specific cases);
  - the fact of not distributing the neutral facilitates the choice of overcurrent protective devices (see section 4.4.1.3) and fault location.
- Locating faults is difficult in widespread networks.
- When an insulation fault in relation to the earth occurs, the voltage of the two unaffected phases in relation to the earth takes on the value of the phase-to-phase voltage (see section 7.16). Equipment must therefore be selected with this in mind.

2.1.2.2. *Directly earthed neutral (TT system)*

## Operating technique:

- Switching upon occurrence of the first insulation fault.

## Technique for protecting persons:

- Earthing of exposed conductive parts combined with the compulsory use of RCDs (at least one at the head of the installation).
- All exposed conductive parts protected by the same RCD must be connected to the same earth.
- Simultaneously accessible exposed conductive parts must be connected to the same earth.

## Advantages:

- The simplest system to design, implement, monitor and use.



- Does not require permanent monitoring during use (only a periodic inspection test of the RCDs may be necessary).
- Moreover, the presence of RCDs prevents the risk of fire when their sensitivity is below or equal to 500 mA (see standard IEC 60364-4, section 482.2.10).
- Easy location of faults.
- Upon occurrence of an insulation fault, the short-circuit current is small.

Disadvantages:

- Switching upon occurrence of the first insulation fault.
- Use of an RCD on each outgoing feeder to obtain total selectivity.
- Special measures must be taken for the loads or parts of the installation causing high leakage currents during normal operation in order to avoid spurious tripping (feed the loads by insulating transformers or use high threshold RCDs, compatible with the exposed conductive part earth resistance).

2.1.2.3. *Connecting the exposed conductive parts to the neutral (TNC – TNS systems)*

Operating technique:

- Switching upon occurrence of the first insulation fault.

Technique for protecting persons:

- Imperative interconnection and earthing of exposed conductive parts.
- Switching on occurrence of the first fault via an overcurrent protective device (circuit-breaker or fuse).

Advantages:

- The TNC system may be less costly upon installation (elimination of one switchgear pole and one conductor).
- Use of overcurrent protective devices to ensure protection against indirect contact.

Disadvantages:

- Switching on occurrence of the first insulation fault.
- The TNC system involves the use of fixed and rigid trunkings (see section 413.1.3.2 of standard IEC 60364-4).
- Requires earthing connections to be evenly placed in the installation so that the protective conductor remains at the same potential as the earth.
- A tripping check on occurrence of the insulation fault should be carried out, if possible, when the network is being designed using calculations, and must be performed during commissioning using measurements; this check is the only

guarantee that the system operates both on commissioning and during operation, as well as after any kind of work on the network (modification, extension).

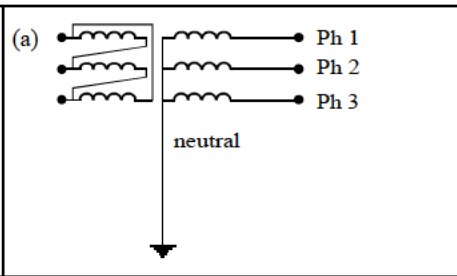
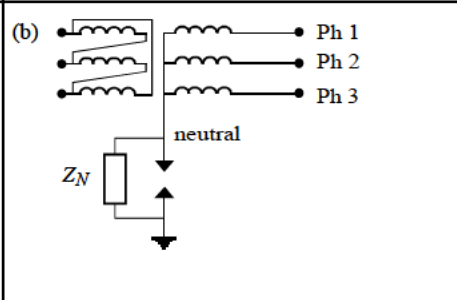
- Passage of the protective conductor in the same trunkings as the live conductors of the corresponding circuits.
- Often requires extra equipotential bonding.
- Third and multiples of third harmonics circulate in the protective conductor (TNC system).
- The fire risk is higher and, moreover, it cannot be used in places presenting a fire risk (TNC system).
- Upon occurrence of an insulation fault, the short-circuit current is high and may cause damage to equipment or electromagnetic disturbance.

**2.2. Medium voltage earthing systems**

We shall first define the different medium voltage earthing systems and then compare the advantages and disadvantages of each one.

**2.2.1. Different earthing systems – definitions and arrangements**

Earthing systems in medium voltage (see Table 2-1) can be differentiated according to the neutral point connection method.

<p>Directly earthed neutral</p> <p>An electrical connection is made between the neutral point and earth.</p>	 <p>(a)</p>
<p>Unearthed neutral</p> <p>There is no electrical connection between the neutral point and earth, except for measuring or protective devices.</p> <p>High impedance earthing</p> <p>A high impedance is inserted between the neutral point and earth.</p>	 <p>(b)</p>

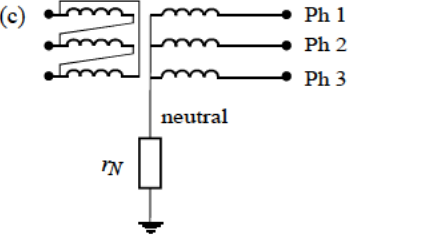
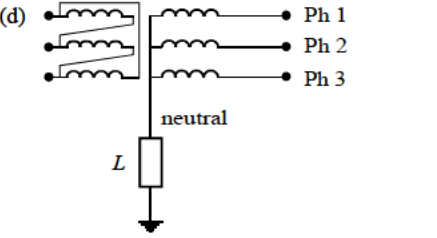
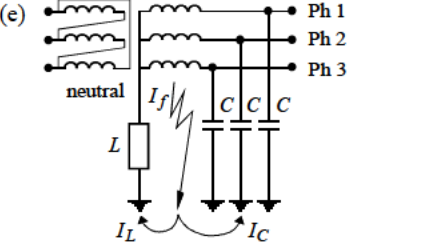
<p>Resistance earthing A resistor is inserted between the neutral point and earth.</p>	<p>(c)</p> 
<p>Reactance earthing A reactor is inserted between the neutral point and earth.</p>	<p>(d)</p> 
<p>Petersen coil earthing A reactor L tuned to the network capacities is inserted between the neutral point and earth so that if an earth fault occurs, the fault current is zero.</p>	<p>(e)</p>  $\vec{I}_f = \vec{I}_L + \vec{I}_C$ <p><math>I_f</math> : fault current</p> <p><math>I_L</math> : current in the neutral earthing reactor</p> <p><math>I_C</math> : current in the phase-earth capacitances</p>

Table 2-1: neutral point connection methods

### **2.2.2. Comparison of different medium voltage earthing systems**

The various earthing systems in medium voltage systems are different in the way they operate and each has its advantages and disadvantages, which we shall now consider.

#### *2.2.2.1. Direct earthing (see Table 2-1(a))*

Operating technique:

- Compulsory switching on occurrence of the first insulation fault.

Advantages:

- Reduces the risk of overvoltages occurring.
- Authorizes the use of equipment with a normal phase to earth insulating level.

Disadvantages:

- Compulsory tripping upon occurrence of the first fault.
- Very high fault currents leading to maximum damage and disturbance (creation of induced currents in telecommunication networks (see section 5.7) and auxiliary circuits).
- The risk for personnel is high while the fault lasts; the touch voltages which develop being high.
- Requires the use of differential protection devices (see section 7.6) so that the fault clearance time is not long. These systems are costly.

#### *2.2.2.2. Unearthed (see Table 2-1(b))*

Operating technique:

- No switching on occurrence of the first insulation fault – it is thus compulsory:
  - to carry out permanent insulation monitoring;
  - to indicate the first insulation fault;
  - to locate and clear the first insulation fault;
  - to switch upon occurrence of the second insulation fault (double fault).

Advantages:

- Provides continuity of service by only tripping upon occurrence of the second fault, subject to the network capacity not leading to a high earth fault current that would be dangerous for personnel and loads on occurrence of the first fault.

Disadvantages:

– The unearthed neutral involves:

- the use of equipment whose phase-to-earth insulation level is at least equal to that of the phase-to-phase level; indeed, when a permanent phase-earth fault occurs, the voltage of both unaffected phases in relation to earth takes on the value of the phase-to-phase voltage if tripping is not triggered on occurrence of the first fault (see section 7.16); cables, rotating machines, transformers and loads must therefore be chosen with this in mind;

- the risk of high internal overvoltages making it advisable to reinforce the equipment insulation;

- the compulsory insulation monitoring, with visual and audible indication of the first fault if tripping is not triggered until the second fault occurs;

- the presence of maintenance personnel to monitor and locate the first fault during use;

- some difficulties implementing selective protection devices upon occurrence of the first fault (see section 7.4.3, directional earth fault protection);

- the risk of ferro-resonance.

#### 2.2.2.3. *Limiting resistance earthing (see Table 2-1(c))*

Operating technique:

– Switching upon occurrence of the first fault.

Advantages:

– Limits fault currents (reduced damage and disturbance).

– Dampens overvoltages of internal origin in that the limiting current  $I_\ell$  is twice as high as the capacitive current  $I_C$  giving  $I_\ell > 2I_C$ .

– Does not require the use of equipment, and in particular cables, having a special phase/earth insulation level.

– Allows the use of simple selective protection devices.

Disadvantages:

– Tripping on the first fault.

#### 2.2.2.4. *Limiting reactance earthing (see Table 2-1(d))*

Operating technique:

– Switching upon occurrence of the first insulation fault.

## Advantages:

- Limits the fault currents (reduced damage and disturbance).
- Allows the implementation of simple selective protection devices if  $I_L \gg I_C$ .
- The coil, being of low resistance, does not have to dissipate a high heat load.

## Disadvantages:

- May cause high overvoltages during earth fault clearance.
- Compulsory tripping upon occurrence of the first fault.

## 2.2.2.5. Petersen coil earthing (see Table 2-1(e))

## Operating technique:

- No switching upon occurrence of the first fault.

## Advantages:

- If the reactance is such that  $3 L_0 C_0 \omega^2 = 1$  is respected, the phase-earth fault current is zero:
  - spontaneous clearance of non-permanent earth faults;
  - the installation continues to operate in spite of there being a permanent fault, with tripping necessarily occurring on the second fault;
  - the first fault is indicated by the detection of the current flowing through the coil. The coil is dimensioned so that permanent operation is possible.

## Disadvantages:

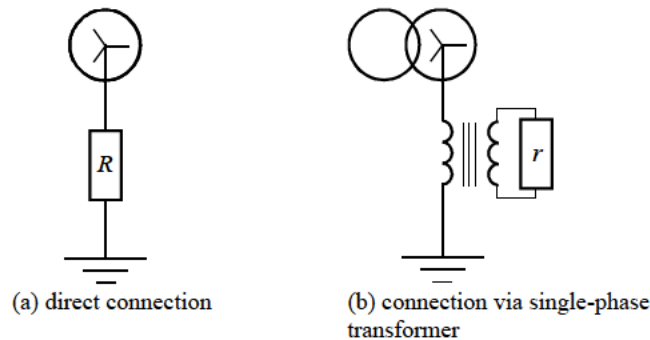
- Difficulties establishing the condition  $3 L_0 C_0 \omega^2 = 1$  due to uncertain knowledge of the network's capacity: the result is that throughout the duration of the fault, a residual current circulates in the fault. Care must be taken to make sure this current is not dangerous for personnel and equipment.
- The risk of overvoltages occurring is high.
- Requires the presence of monitoring personnel.
- Impossible to provide selective protection upon occurrence of the first fault if the coil has been tuned to  $3 L_0 C_0 \omega^2 = 1$ ; if it is systematically out of tune ( $3 L_0 C_0 \omega^2 \neq 1$ ) selective protection upon occurrence of the first fault is complex and costly (see section 7.5, directional earth fault protection for compensated neutral systems).
- Risk of ferro-resonance.

### 2.3. Creating neutral earthing

#### 2.3.1. MV installation resistance earthing

##### *Earthing when the neutral is accessible*

A resistor is inserted between the neutral outlet terminal and the earthing connection, either directly (see Figure 2-6(a)), or via a single-phase transformer connected to the secondary via an equivalent resistor (see Figure 2-6(b)). This system is applied when the network is fed by a transformer with a star-connected secondary and an accessible neutral, or by a generator with an accessible neutral.



**Figure 2-6:** earthing when the neutral is accessible

##### *Earthing by creating an artificial neutral*

When the source neutral is not accessible (delta winding), the system is earthed by creating an artificial neutral (also referred to as an earthing transformer).

The artificial neutral can also be used when there are several parallel sources.

The earthing transformer can be made in various ways:

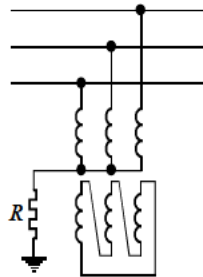
- using a star-delta transformer, the limiting resistor is connected between the primary neutral point and earth, the delta being closed in on itself (see Figure 2-7(a));

- using a star-delta transformer whose primary neutral point is directly earthed, a fault current limiting resistor is inserted in the secondary delta (see Figure 2-7(b)). This system is economically preferable in case (a) since the resistor is in LV and not in MV;

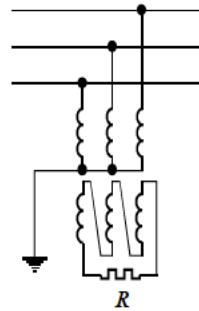
- using a zig-zag coil, the limiting resistor being connected between the neutral point of the coil and earth (see Figure 2-7(c));

– using a neutral point transformer, this type of earthing transformer includes an extra winding which creates a power outlet: for example, a primary star winding with earthed neutral, a secondary delta winding closed by a fault current limiting resistor and another secondary star winding allowing the loads as well as the auxiliaries of an HV/MV substation to be fed (see Figure 2-7(d)).

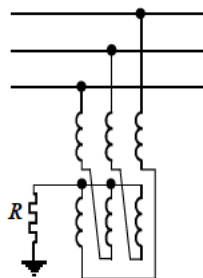
– the systems adopted the most often are (b) and (c).



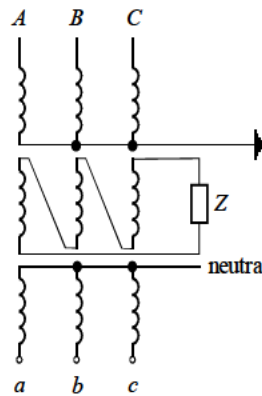
(a) Use of a star-delta transformer with neutral earthing resistor



(b) Use of a star-delta transformer with resistor in the delta



(c) Use of zig-zag coil



(d) Neutral point transformer with compensation delta

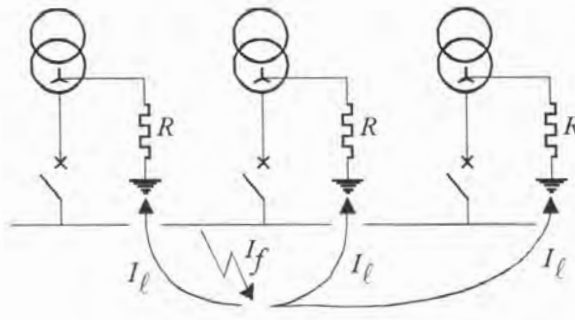
**Figure 2-7:** main methods for creating an artificial neutral point at medium voltage



**Problem of resistance earthing when several transformers operate in parallel on one busbar**

*Case 1:* Each transformer has a non-disconnectable earthing resistor.

The earth fault current varies according to the number of transformers in service (see Figure 2-8a), which may pose difficulties for the motors or for setting the threshold of earth fault protection devices. Moreover, directional earth fault protection devices must be used (see section 7.4) to locate faults coming from connections linking the transformers to the busbars (see section 10.1.5.2).

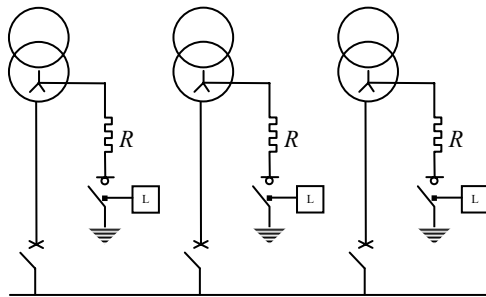


**Figure 2-8a:** direct earthing of each neutral point

*Case 2:* Each transformer has a disconnectable earthing resistor.

A switching device makes it possible to have a single earthed neutral point whatever the number of transformers in service (see Figure 2-8b). The protective system is complex since it uses logical selectivity, taking into account the position of the switching devices and the state of the different earth fault protection devices.

This system is used very little.

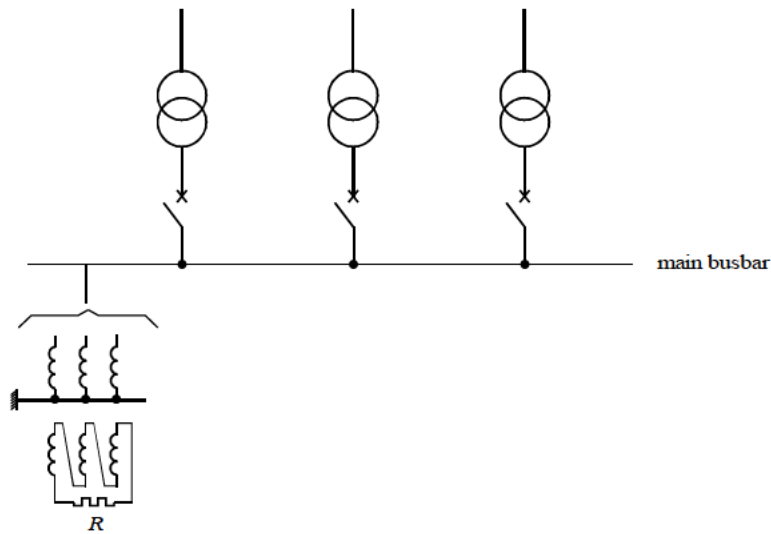


L: control logic taking into account the network configuration

**Figure 2-8b:** earthing of each neutral point using a switching device

*Case 3: No transformer has an earthing resistor.*

An artificial neutral point is created on the main switchboard busbar (see Figure 2-9). This method eliminates the problems of cases 1 and 2. Indeed, the fault current is constant, whatever the number of transformers in service; the protection devices to be implemented are simple since they do not require the use of directional or complex logic protection devices (see section 10.1.5.2).



**Figure 2-9:** earthing transformer on main busbar

Note: the problem is identical when an internal generation set is made up of several generators.

***Problem of resistance earthing when several transformers operate in parallel on two busbars***

The two busbars may or may not be coupled depending on the operating mode. It is therefore necessary to install an artificial neutral on each busbar. When the busbars are separate, the two neutral points are in service. When the two busbars are coupled, only one artificial neutral must be connected (see Figure 2-10) so that the fault current is not doubled. A control logic must then be installed to put one of the two artificial neutrals out of service when the coupler circuit-breaker is closed. This logic may be indispensable when some loads, especially motors, cannot withstand high fault currents.

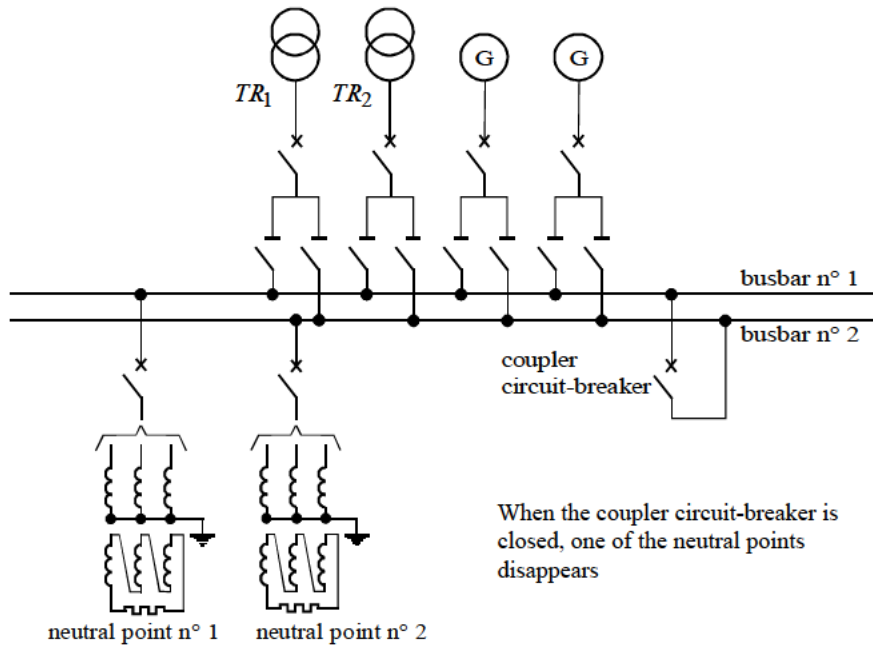


Figure 2-10: artificial neutral point switching

### 2.3.2. Reactance or Petersen coil earthing of an MV installation

The method of using an accessible neutral or creation of an artificial neutral is identical to that used for resistance earthing except that a reactor is used instead of a resistor (see Figures 2-6 and 2-7).

### 2.3.3. Direct earthing of an MV or LV installation

The neutral must be accessible and is directly earthed.

## 2.4. Specific installation characteristics in LV unearthed systems

As we saw in section 2.1.2.1, the LV unearthed system requires permanent insulation monitoring, first fault location and an overvoltage limiter. We shall now look at how this is done.

#### 2.4.1. Installing a permanent insulation monitor (see Figure 2-11)

In an unearthed system, a device must permanently monitor the insulation level so that a fault does not last indefinitely. This is necessary to avoid any partial deterioration of equipment over the course of time and avoid tripping if a second insulation fault occurs (this would constitute a phase-to-phase fault). The first fault must be located and cleared by operating personnel.

The permanent insulation monitor ensures insulation monitoring.

It applies a direct voltage between the neutral and earth, or on a phase if the neutral is not accessible, which creates a leakage current in the insulation resistors whatever the cable capacities (with direct current, the capacitors have an infinite impedance). If an insulation fault occurs, a direct current flows through the monitor and causes an alarm to go off.

#### 2.4.2. Installing an overvoltage limiter (see Figure 2-11)

The job of an overvoltage limiter is to run off to earth dangerous overvoltages that are likely to occur, such as a lightning impulse or flashover between the MV and LV windings of a transformer.

It is installed between the neutral and earth of a transformer or between a phase and earth if the neutral is not accessible.

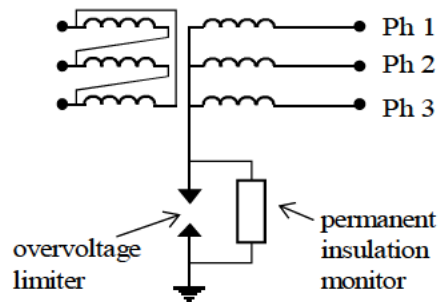


Figure 2-11: installation of an overvoltage limiter and a permanent insulation monitor in an IT system

#### 2.4.3. Location of earth faults by a low frequency generator (2–10 Hz)

This device allows earth faults to be located while energized (see Figure 2-12).

A low frequency generator between 2 and 10 Hz (1) injects a current between the network and the earth. When an insulation fault occurs on an outgoing feeder, a low frequency leakage current is run off to earth. This current can be detected:

- manually using a clip-on ammeter (2) connected to a selective amplifier (3) tuned to the generator frequency. Each feeder is thus tested until the amplifier detects a current.
- by Tore transformers (4) (see section 7.2) installed on each outgoing feeder. These are connected to a selective switch (5) which determines the faulty feeder.
- The switch is connected to a selective amplifier (3) tuned to the generator frequency.

Note: an injection of direct current cannot be used to locate an earth fault since a tore transformer or clip-on ammeter can only detect alternating current. The selective amplifier is generally able to discriminate between a resistive current due to an insulation fault and the capacitive current of a healthy feeder (if a fault occurs, the healthy feeders have a capacitive current proportional to the cable capacity (see section 4.3)). If the selective amplifier cannot perform this task, the capacitive currents of some healthy feeders (the longer ones) are likely to be as great as the fault current, thereby making it difficult to locate the fault. The Vigilohm range from Schneider can perform this task and furthermore it is insensitive to harmonic disturbances.

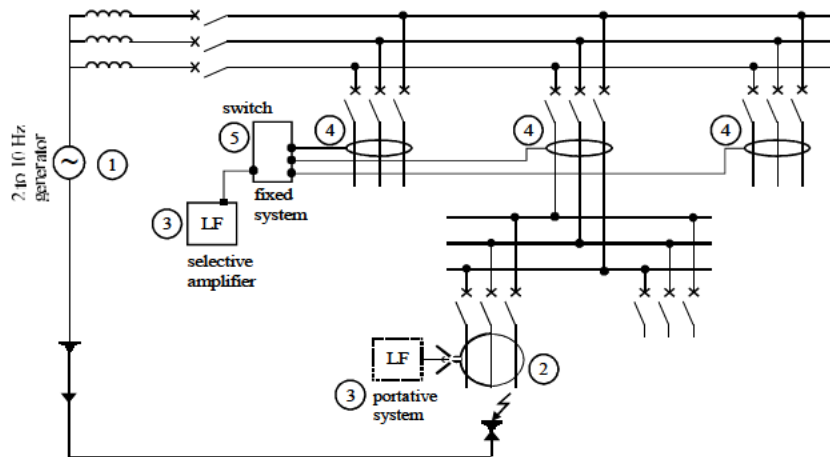


Figure 2-12: location of an insulation fault using a low frequency generator

**2.5. Specific installation characteristics of an MV unearthed system**

As shown in section 2.2.2.1, the MV unearthed system must be fitted with insulation monitoring and first insulation fault location.

**2.5.1. Insulation monitoring**

This can be done using residual overvoltage protection or an insulation monitor.

***Insulation monitoring via residual overvoltage protection (see section 7.16)***

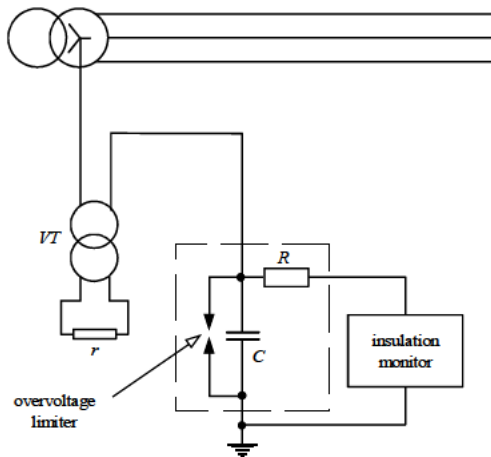
This detects a rise in neutral point potential which is characteristic of an earth fault.

***Insulation monitoring via an insulation monitor***

The insulation monitor applies a direct voltage between the neutral and earth, or between a phase and earth if the neutral is not accessible. If an insulation fault occurs, a direct current goes through the monitor, causing an alarm to go off.

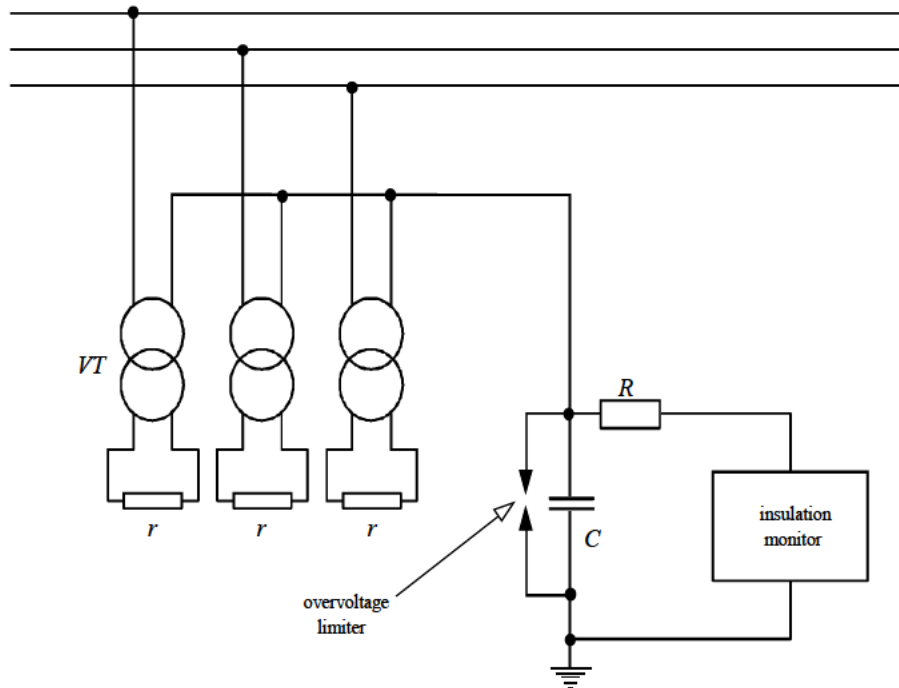
The monitor is connected to the network via voltage transformers, so that the voltage applied to it is not too high.

In the case of an accessible neutral, it is connected to the voltage transformer primary measuring the neutral potential (see Figure 2-13).



**Figure 2-13:** installation of an insulation monitor in the case of an accessible neutral

In the case of an inaccessible neutral, it is connected to the primary, on the neutral point of the three voltage transformers (see Figure 2-14).



**Figure 2-14:** installation of an insulation monitor in the case of an inaccessible neutral

For Schneider equipment, a standard plate is connected in parallel and is made up of:

- a capacitor allowing the neutral potential of the voltage transformers to be fixed to earth without the direct current injected by the monitor being shunted;
- an overvoltage limiter allowing overvoltages to be run off to earth;
- a resistor allowing the voltage withstood by the monitor to be reduced.

Note: the voltage transformers must be loaded to avoid ferro-resonance phenomena from occurring in an unearthed system. This is what the secondary-connected  $r$  resistors are used for (see Figures 2-13 and 2-14).

If there are other star-connected voltage transformers in the same network, the following must be installed:

- a capacitor between the neutral of the voltage transformers and earth so that the monitor does not deliver a direct current via the voltage transformers (if this was the case, it would continually detect a fault). The advisable value of the capacitor is 2.5  $\mu\text{F}$  with an insulation voltage of 1,600 V.

- an overvoltage limiter allowing overvoltages to be run off to earth.

When two networks with an insulation monitor can be coupled, a logic must be made so that the two monitors cannot operate in parallel because, if they did, one would deliver current into the other and they would continually detect a fault.

#### ***2.5.2. Location of the first insulation fault***

This can be done in one of two of the following ways:

- by an efficient selectivity system (see sections 10.1.4.2, 10.1.5.2 and 10.1.6.2);
- by successive tripping of each feeder until the fault is cleared.

The latter method is not recommended as it leads to switching on the healthy feeders and overvoltages able to generate a double fault.



## Chapter 3

# Main Faults Occurring in Networks and Machines

### 3.1. Short-circuits

#### 3.1.1. *Short-circuit characteristics*

Short-circuits can be defined according to three main characteristics:

– Their origin:

- they may be mechanical: breakdown of conductors or accidental electrical connection between two conductors via a foreign body such as a tool or animal;

- they may be electrical: following the degradation of the insulation between phases, or between phase and frame or earth, or resulting from internal overvoltages (switching surges) or atmospheric overvoltages (stroke of lightning);

- they may be due to an operating error: earthing of a phase, connection between two different voltage supplies or different phases or closing of a switching device by mistake.

– Their location:

- the short-circuit may be generated inside equipment (cable, motor, transformer, switchboard, etc.), and it generally leads to deterioration;

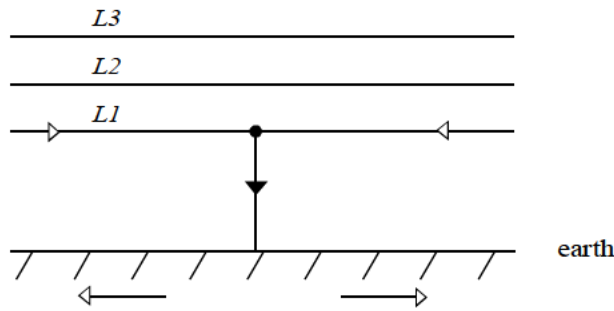
- the short-circuit may be generated outside equipment (cable, motor, transformer, switchboard, etc.). The consequences are limited to disturbances which may, in the course of time, lead to deterioration of the equipment in question and thereby cause an internal fault.

– Their duration:

- *self-extinguishing*: the fault disappears on its own;
- *fugitive*: the fault disappears due to the action of protective devices and does not reappear when the equipment is started up again (the fault is “burnt out” after re-energization);
- *permanent*: these faults require de-energization of a cable, machine, etc., and intervention by the operating personnel.

### 3.1.2. Different types of short-circuits

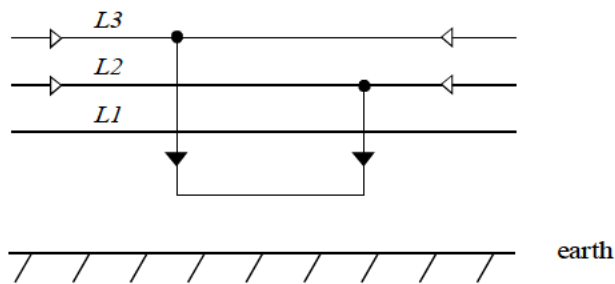
*Phase-to-earth*: 80% of cases\* (see Figure 3-1)



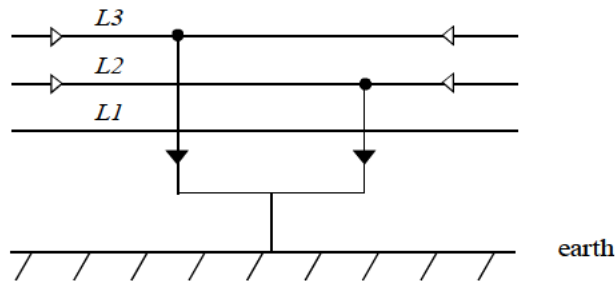
**Figure 3-1:** phase-to-earth short-circuit

*Phase-to-phase*: 15% of cases\* (see Figures 3-2 and 3-3)

These faults often degenerate into three-phase faults.

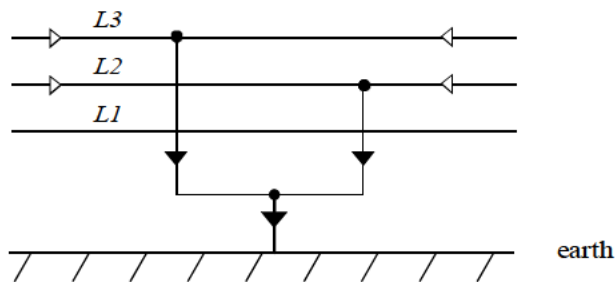


**Figure 3-2:** phase-to-phase short-circuit clear of earth



**Figure 3-3:** *two-phase-to-earth short-circuit*

*Three-phase: 5% of cases (originating as such)\* (see Figure 3-4)*



**Figure 3-4:** *three-phase short-circuits*

See Chapter 4 for the method of calculating short-circuit currents.

### 3.1.3. Causes of short-circuits

- Degradation of insulating materials due to:
  - degradation in surface quality (pollution);
  - excessive temperature;
  - partial discharge in the vacuoles (micropockets) inside the insulating materials.

---

\* The percentages given are for guidance only. They come from fault statistics on public distribution networks. The order of magnitudes must be approximately equivalent in industrial networks. It may be observed therefore that phase-to-earth short circuits are the ones most frequently occurring and that three-phase faults are fairly rare.

- Accidental reduction in electrical insulation (presence of animals, tree branches, tools left by carelessness on a busbar, etc.).
- Destruction due to external causes (hit by a shovel, etc.).
- Overvoltages causing a breakdown in equipment insulation (switching surges or lightning strike).

### **3.2. Other types of faults**

- On motors:
  - too many successive start-ups leading to overheating and mechanical shocks on couplings;
  - excessive start-up time or rotor locking leading to the same result;
- On generators:
  - loss of excitation due to a fault in the rotor circuit (cut, short-circuit, etc.), leading to overheating of the rotor and stator and loss of synchronism with the network;
  - variations in frequency due to an overload or faulty operation of a frequency regulator (for a generator operating cut-off from the utility network).
- Phase opposition connection of a generator with the network or of two parts of a network coming from different sources.
- Overvoltages due to a lightning strike.
- Switching surges (of a switch or circuit-breaker).
- Overloads on cables, transformers, motors or generators.
- Reversal of the direction of energy flow in the absence of an electrical fault. In the event of a power cut or a drop in voltage caused by the utility, an internal generation plant may supply energy to the utility.
- Variations in voltage due to faulty operation of the on-load tap changers of a transformer, or network under or overload.
- The presence of a negative-phase component due to a non-symmetrical voltage source, a large single-phase consumer, a connection error or phase cutting leads to overheating of the motors or generators, and a loss in generator synchronism.

## Chapter 4

# Short-circuits

All electrical installations must be protected against short-circuits every time there is an electrical connection, which is generally when there is a change in conductor cross-section. The short-circuit current value must be calculated at every stage of installation for different possible network configurations. This is done to determine the characteristics of the equipment that must withstand or switch the fault current.

In order to choose the appropriate switching devices (circuit-breakers or fuses) and set the protection functions, four short-circuit values must be known:

***The root mean square value of the maximum short-circuit current (symmetrical three-phase short-circuit)***

This determines:

- the breaking capacity of the circuit-breakers and fuses;
- the temperature stress that the equipment must withstand.

It corresponds to a short-circuit in the immediate vicinity of the downstream terminals of the switching device. It must be calculated to include a good safety margin (maximum value).

***The peak value of the maximum short-circuit current (value of the first peak of the transient period)***

This determines:

- the making capacity of the circuit-breakers and switches;
- the electrodynamic withstand of the trunkings and switchgear.

***The minimum phase-to-phase short-circuit current***

This must be known in order to choose the tripping curve of the circuit-breakers or fuses or set the thresholds of the overcurrent protection devices, especially when:

- the cables are long or when the source has a relatively high internal impedance (e.g. generators);
- protection of persons relies on the phase overcurrent protective devices operating. This is essentially the case in low voltage for TN or IT earthing systems;
- the network requires a study of protection selectivity.

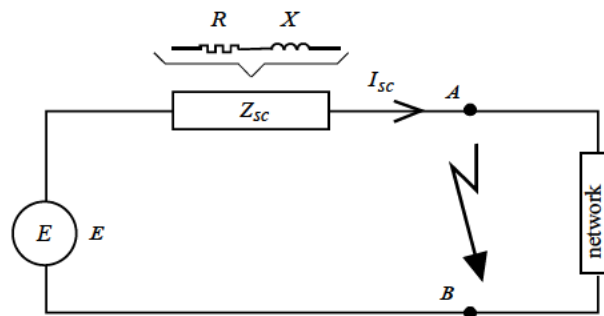
***The value of the phase-to-earth short-circuit current***

It mainly depends on the earthing system and determines the setting of earth fault protections.

**4.1. Establishment of short-circuit currents and wave form**

The network upstream of a short-circuit can be shown in the form of an equivalent diagram having one constant alternating voltage source  $E$  and a series impedance  $Z_{sc}$  (see Figure 4-1).

$Z_{sc}$  represents the sum of cable, line and transformer impedances through which the short-circuit current flows. Each impedance must be recalculated for voltage  $E$  basis.



$E$  : r.m.s. single-phase voltage

**Figure 4-1:** *equivalent diagram of the network upstream of the short-circuit*

A negligible impedance fault between A and B gives rise to a short-circuit current  $I_{sc}$  limited by impedance  $Z_{sc}$ :

$$Z_{sc} = \sqrt{R^2 + X^2} \quad \text{where } X = L\omega$$

In steady-state conditions, the short-circuit current is:  $I_{sc} = \frac{E}{Z_{sc}}$

The real short-circuit current  $I_{sc}$  is established according to a transient state having a non-periodic component and a higher amplitude than during the steady state.

We shall consider two cases because the transient state differs according to whether the short-circuit is located on the power utility's supply (in this case the generators are far enough apart for their effects to be ignored), or whether it is located at the terminals of a generator.

#### 4.1.1. Establishment of the short-circuit at the utility's supply terminals

A voltage of  $e = E\sqrt{2}\sin(\omega t + \alpha)$  is applied to a circuit comprising a resistor and reactor in series.

$\alpha$  represents a switching angle defining the voltage phase upon occurrence of the fault (the voltage sinusoidal phase the moment the fault occurs).

If  $\varphi$  is the phase angle between the voltage and the current, then  $\text{tg } \varphi = \frac{X}{R}$ .

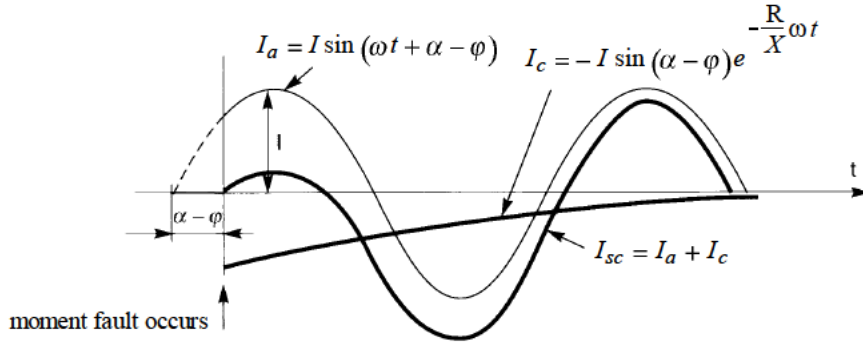
The current expression is shown to be (see Appendix A):

$$I_{sc} = \frac{E\sqrt{2}}{Z_{sc}} \left[ \sin(\omega t + \alpha - \varphi) - \sin(\alpha - \varphi) e^{-\frac{R}{X}\omega t} \right]$$

where:

$$Z_{sc} = \sqrt{R^2 + X^2}$$

$$\text{tg } \varphi = \frac{X}{R}$$



**Figure 4-2:** breakdown of the short-circuit current established at the utility's supply terminals

The current  $I_{sc}$  is the sum of a sinusoidal current:

$$I_a = \frac{E\sqrt{2}}{Z_{sc}} \sin(\omega t + \alpha - \varphi)$$

and an aperiodic current tending towards 0 exponentially (see Figure 4-2):

$$I_c = \frac{E\sqrt{2}}{Z_{sc}} \sin(\alpha - \varphi) e^{-\frac{R}{X}\omega t}$$

If  $\alpha = \varphi$  at the moment the fault occurs, the aperiodic component is zero and the state is said to be symmetrical.

If  $\alpha - \varphi = \frac{\pi}{2}$  at the moment the fault occurs, the aperiodic component is at its maximum and the state is referred to as a maximum asymmetrical state, which is the condition that leads to the highest current peak value, thus:

$$I_{sc} = \frac{E\sqrt{2}}{Z_{sc}} \left[ \sin\left(\omega t + \frac{\pi}{2}\right) - e^{-\frac{R}{X}\omega t} \right]$$

The current value is peak for  $\sin\left(\omega t + \frac{\pi}{2}\right) = -1$  hence  $\omega t = \pi$ .

The peak value of the current is thus:

$$\hat{I} = \frac{E\sqrt{2}}{\sqrt{R^2 + X^2}} \left[ 1 + e^{-\frac{R}{X}\pi} \right]$$



Let us define the coefficient  $K$  which characterizes the ratio of the peak transient current to the steady-state r.m.s. current:

$$\hat{I} = K I_a \quad \text{where } I_a = \frac{E}{Z_{sc}} \text{ steady-state r.m.s. current}$$

$$K = \sqrt{2} \left( 1 + e^{-\frac{R}{X}\pi} \right)$$

Note: the factor  $\sqrt{2}$  comes from the fact that a *peak* current is being compared to a steady-state *root mean square* current.

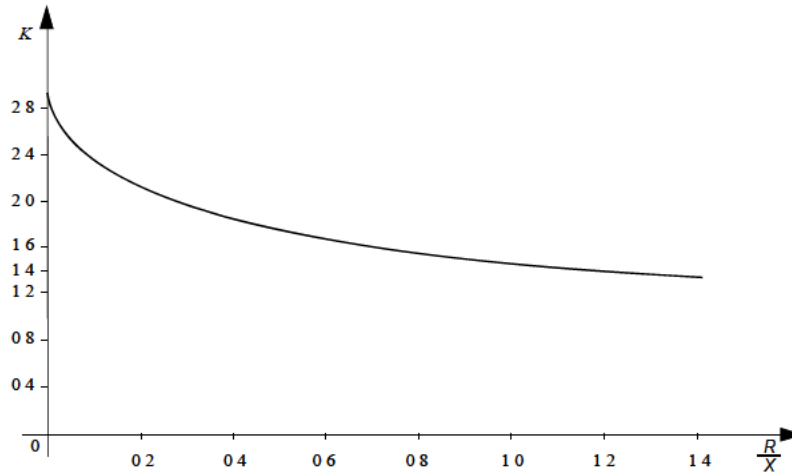
It is interesting to define  $K$  in relation to the ratio  $\frac{R}{X}$ , which characterizes the network (see Table 4-1 and Figure 4-3).

Generally the ratio  $\frac{R}{X}$  is:

- between 0.05 and 0.3 for HV or MV;
- between 0.3 and 0.6 for LV (near transformers).

$\frac{R}{X}$	0	0.05	0.1	0.2	0.3	0.4	0.5	0.6	$\infty$
$K$	2.83	2.62	2.45	2.17	1.97	1.82	1.71	1.63	1.41
$\frac{K}{\sqrt{2}}$	2	1.85	1.73	1.53	1.39	1.29	1.21	1.15	1

**Table 4-1:**  $K$  values, ratio between the peak transient current and the steady-state current, according to  $\frac{R}{X}$



**Figure 4-3:** development of  $K$ , ratio between the peak transient current and the steady-state current, with respect to  $\frac{R}{X}$

**Example**

Development of the current peak values, ratio  $\frac{\hat{I}}{I_a}$  in relation to time (see Table

4-2).  $I_a$  is the steady-state r.m.s. current:

$$\frac{\hat{I}}{I_a} = \sqrt{2} \left[ \sin \left( \omega t + \frac{\pi}{2} \right) - e^{-\frac{R}{X} \omega t} \right]$$

The peak values occur at time:

$$t = \left( p + \frac{1}{2} \right) T$$

where  $p$  is an integer and  $T = \frac{2\pi}{\omega}$  is voltage period ( $T = 20$  ms for  $f = 50$  Hz), thus:

$$\frac{\hat{I}}{I_a} = \sqrt{2} \left[ 1 + e^{-\frac{R}{X} \omega t} \right] = \sqrt{2} \left[ 1 + e^{-\frac{R}{X} (2p+1)\pi} \right]$$

t (ms)	10 (p = 0)	30 (p = 1)	50 (p = 2)	70 (p = 3)	$\infty$
0.05	2.62	2.30	2.06	1.89	1.41
0.1	2.45	1.97	1.71	1.57	1.41
0.2	2.17	1.63	1.48	1.43	1.41
0.3	1.97	1.50	1.43	1.42	1.41

**Table 4-2:** development of  $\frac{\hat{I}}{I_a}$  in relation to the time for ratios  $\frac{R}{X}$  equal to 0.05, 0.1, 0.2 and 0.3

### Conclusion

When a short-circuit occurs in an installation fed by a distribution network (far from the generators), a transient current occurs which lasts for several periods, i.e. between 20 and 80 ms. However, when circuit-breakers are not time-delayed, they generally have a lower tripping time than the duration of the aperiodic current and should therefore be able to break the aperiodic component (see section 8.2 for MV circuit-breakers and section 8.1 for LV circuit-breakers). For LV circuit-breakers, the breaking capacity is defined in relation to  $\cos \varphi = \frac{R}{\sqrt{X^2 + R^2}}$  (Table 8-2).

The peak value of the transient current is 1.6 to 2.5 times higher than the short-circuit current value in steady-state conditions. It determines the electrodynamic forces that the trunkings and switchgear must withstand and the making capacity of the switching devices (see section 5.2).

#### 4.1.2. Establishment of the short-circuit current at the terminals of a generator

It is assumed that the short-circuit is close enough to the generator for the cable impedance to be ignored compared with the generator impedance.

Calculations on transient states of synchronous machines show that the current is expressed by:

$$i(t) = E \sqrt{2} \left[ \left( \frac{1}{X_d''} - \frac{1}{X_d'} \right) e^{-t/T_d''} + \left( \frac{1}{X_d'} - \frac{1}{X_d} \right) e^{-t/T_d'} + \frac{1}{X_d} \right] \cos(\omega t + \alpha) - \frac{E \sqrt{2}}{X_d'} e^{-t/T_d} \cos \alpha$$

$\alpha$  represents a switching angle defining the voltage phase upon occurrence of the fault (the voltage sine curve phase at the moment the fault occurs). Current  $i(t)$  is maximum for  $\alpha = 0$ .

Thus:

$$i(t) = E \sqrt{2} \left[ \left( \frac{1}{X_d''} - \frac{1}{X_d'} \right) e^{-t/T_d''} + \left( \frac{1}{X_d'} - \frac{1}{X_d} \right) e^{-t/T_d'} + \frac{1}{X_d} \right] \cos \omega t - \frac{E \sqrt{2}}{X_d''} e^{-t/T_a}$$

$E$  : single-phase r.m.s. voltage at the generator terminals

$X_d''$  : subtransient reactance

$X_d'$  : transient reactance

$X_d$  : synchronous reactance

$T_d''$  : subtransient time constant

$T_d'$  : transient time constant

$T_a$  : aperiodic time constant

The current is the sum of the aperiodic current:

$$i_c = -\frac{E \sqrt{2}}{X_d''} e^{-t/T_a}$$

and of a damped sinusoidal current:

$$i_a = E \sqrt{2} \left[ \left( \frac{1}{X_d''} - \frac{1}{X_d'} \right) e^{-t/T_d''} + \left( \frac{1}{X_d'} - \frac{1}{X_d} \right) e^{-t/T_d'} + \frac{1}{X_d} \right] \cos \omega t$$

The aperiodic component has a high value but a very short duration, from 10 to 60 ms (see Tables 4-3, 4-4 and 4-5 showing the aperiodic time constant values  $T_a$ ).

For the damped sinusoidal component, the electrical variables evolve as if the machine reactance was variable and developed according to the three following periods:

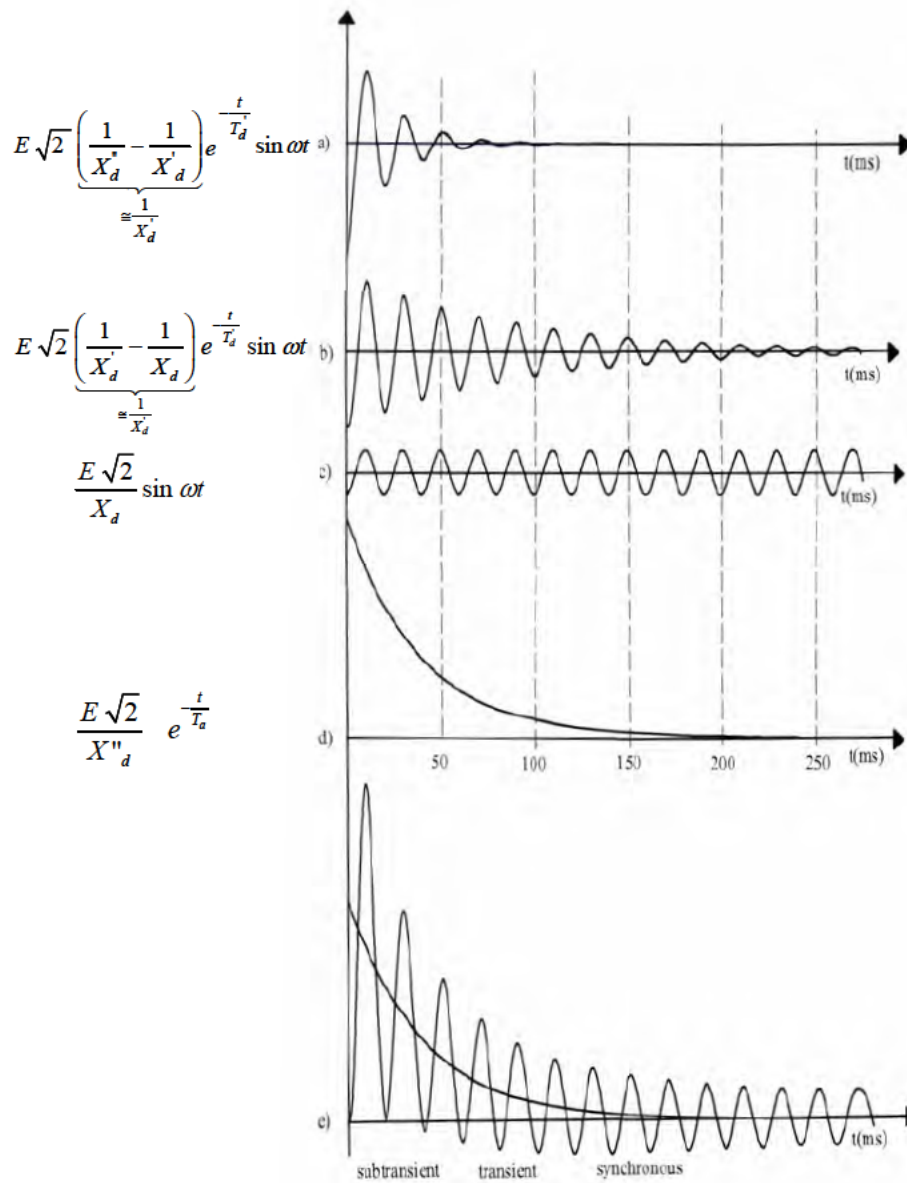
- subtransient ( $X_d''$ ): lasting 10 to 20 ms after the start of the fault;
- transient ( $X_d'$ ): lasting up to 100 to 400 ms;
- synchronous ( $X_d$ ): synchronous reactance to be considered after the transient period.

Let us note that in the order given, this reactance takes a higher value for each period:

$$X_d'' < X_d' < X_d$$

This leads to a gradual decrease in the short-circuit current.

The short-circuit current is thus the sum of four components (see Figure 4-4).



**Figure 4-4:** contribution to the total short-circuit current  $I_{sc}$  of a) subtransient reactance; b) transient reactance; c) steady-state or synchronous reactance; d) aperiodic component

It should be noted that the decrease in generator reactance is faster than that of the aperiodic component. This rare case may raise switching difficulties for the circuit-breakers and saturation problems for the magnetic circuits as the current does not reach zero until after several periods.

**Standard electrical characteristics of generators**

The values  $X_d''$ ,  $X_d'$  and  $X_d$  are expressed as percentages (see section 4.2.1.3).

S (kVA)	75	200	400	800	1,600	2,500
$X_d''$ (%)	10.5	10.4	12.9	10.5	18.8	19.1
$X_d'$ (%)	21	15.6	19.4	18	33.8	30.2
$X_d$ (%)	280	291	358	280	404	292
$T_a$ (ms)	9	15	22	28	47	65
$T_d''$ (ms)	6	10	14	18	22	23
$T_d'$ (ms)	80	30	140	160	235	320

**Table 4-3:** electrical characteristics of Leroy-Somer 75 to 2,500 kVA three-phase, four-pole generators with a phase-to-phase voltage of 400 V and frequency of 50 Hz

S (kVA)	2,200	2,800	3,500
$X_d''$ (%)	15.5	14	13
$X_d'$ (%)	25.5	24.5	23
$X_d$ (%)	235	230	225
$T_a$ (ms)	50	54	57
$T_d''$ (ms)	22	24	26
$T_d'$ (ms)	240	260	280

**Table 4-4:** electrical characteristics of Leroy-Somer 2,200, 2,800 and 3,500 kVA three-phase, four-pole generators with a phase-to-phase voltage of 6 kV and frequency of 50 Hz

S (kVA)	1,500	2,500	3,250
$X_d''$ (%)	15.5	14.5	14
$X_d'$ (%)	27.5	26.5	25.5
$X_d$ (%)	255	255	250
$T_a$ (ms)	37	46	52
$T_d''$ (ms)	21	24	26
$T_d'$ (ms)	230	260	280

**Table 4-5:** electrical characteristics of Leroy-Somer 1,500, 2,500 and 3,250 kVA three-phase, four-pole generators with a phase-to-phase voltage of 11 kV and frequency of 50 Hz

**Development of short-circuit current peak values,  $\frac{\hat{I}}{\sqrt{2}I_n}$  in relation to the time**

(see Table 4-6)

$I_n$  is the nominal current of the generator.

The peak values occur at times  $t = \left(p + \frac{1}{2}\right)T$

where  $p$  is an integer and  $T = \frac{2\pi}{\omega}$  is voltage period ( $T = 20$  ms for  $f = 50$  Hz), thus:

$$\frac{\hat{I}}{\sqrt{2}I_n} = \left[ \left( \frac{100}{X_d''} - \frac{100}{X_d'} \right) e^{-t/T_d''} + \left( \frac{100}{X_d'} - \frac{100}{X_d} \right) e^{-t/T_d'} + \frac{100}{X_d} \right] + \frac{100}{X_d''} e^{-t/T_a}$$

where the values  $X_d''$ ,  $X_d'$  and  $X_d$  are expressed as percentages (see section 4.2.1.3).

t(ms)	10	30	50	90	150	310	610	$\infty$
S (kVA)								
75	8.3	3.8	2.8	1.8	1	0.45	0.36	0.36
200	10.81	4.04	1.86	0.67	0.39	0.344	0.344	0.344
400	11	6.5	4.6	3	2	0.81	0.34	0.28
800	14.2	8.7	6	3.7	2.4	1.1	0.47	0.36

**Table 4-6:** development of  $\frac{\hat{I}}{\sqrt{2}I_n}$  in relation to the time for the 75, 200, 400 and 800 kVA generators defined in Table 4-3

***Holding the short-circuit current at approximately  $3 I_n$  for several seconds***

When the subtransient and transient periods are over, i.e. after a time of 0.5 to 1 second, the short-circuit current is lower than the nominal current, i.e. from 0.3 to  $0.5 I_n$  (see Table 4-6).

The values given above are design values.

In practice, manufacturers like Leroy-Somer have methods for holding the short-circuit current at approximately  $3 I_n$  for several seconds to allow the protective devices to operate when they are time-delayed, for selectivity reasons, for a time greater than  $T_d' \approx 100$  ms. The holding value  $3 I_n$  is close to the current value during the transient period where:

$$I_{sc} \approx \frac{E}{X_d'} \quad \text{where } X_d' \approx 30\%$$

$I_{sc}$  is thus close to  $3 I_n$ .

When the current is not held at  $3 I_n$ , protection against short-circuits may be provided by voltage restrained overcurrent protection (see section 7.24).

Note: the method generally used to hold the short-circuit current at  $3 I_n$  is compound excitation, i.e. series-parallel excitation. The parallel voltage drops when a short-circuit occurs, leading to a drop in parallel excitation; the short-circuit current, however, is higher than the nominal current and the series excitation increases. Combined, the two phenomena lead to a short-circuit current held at  $3 I_n$  for several seconds.

**4.2. Short-circuit current calculating method**

The short-circuit current calculating method presented in this document is the impedance method. It is applied to calculations by hand and produces sufficiently accurate results for most applications.

It helps with the understanding of more accurate methods, such as IEC 60909, which are generally applied using computer software programs.

The aim of this section is to give all the elements needed to calculate the following short-circuits:

- symmetrical three-phase fault;



- phase-to-earth fault;
- phase-to-phase fault clear of earth;
- two-phase-to-earth fault;

at any point in a network.

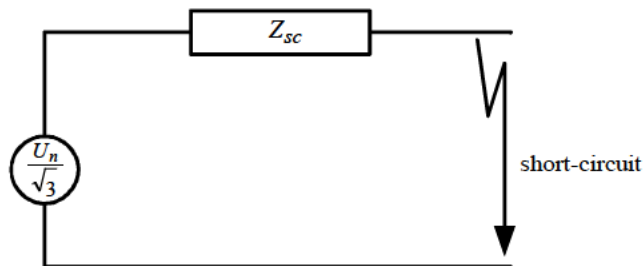
A detailed calculation of the symmetrical three-phase short-circuit at different points in a network is provided as an example at the end of section 4.2.1.

#### 4.2.1. Symmetrical three-phase short-circuit

This fault corresponds to that shown in Figure 3-4.

In general, it causes the greatest fault currents. It must therefore be calculated for the appropriate equipment to be chosen (maximum current and electrodynamic stress to be withstood).

The three-phase short-circuit current calculation is simple due to the symmetrical nature of the short-circuit. The short-circuit current has the same value in each phase. A calculation can thus be made using an equivalent single-phase diagram of the network upstream of the short-circuit (see Figure 4-5), as can be done under normal operating conditions.



**Figure 4-5:** equivalent single-phase diagram of the network upstream of the short-circuit

The three-phase short-circuit value  $I_{sc3}$  is thus: 
$$I_{sc3} = \frac{U_n}{\sqrt{3} Z_{sc}}$$

where:

$U_n$ : phase-to-phase voltage

$Z_{sc}$ : impedance equivalent to all the impedances through which the fault current flows, from the source up to the presumed fault

$$Z_{sc} = \sqrt{(\Sigma R)^2 + (\Sigma X)^2}$$

$\Sigma R$  : sum of series resistances through which the fault current flows

$\Sigma X$  : sum of series reactances through which the fault current flows

In practice, the equivalent supply source impedance is calculated first (power supply provided by the utility or generator), then the impedances of each transformer, cable or line through which the fault flows.

Each impedance must be recalculated for the voltage level of the presumed fault (see section 4.2.1.1).

Note: in medium and high voltage, standard IEC 60909 (Table 1) applies a coefficient of 1.1 to the nominal voltage in order to calculate the maximum short-circuit current, thereby giving:

$$I_{sc3} = \frac{1.1 U_n}{\sqrt{3} Z_{sc}} \quad (\text{in MV and HV})$$

#### 4.2.1.1. Equivalent impedance of an element across a transformer

For example, for a low voltage fault, the contribution of a cable upstream of the MV/LV transformer will be:

$$R_{LV} = R_{HV} \left( \frac{U_{LV}}{U_{HV}} \right)^2$$

and

$$X_{LV} = X_{HV} \left( \frac{U_{LV}}{U_{HV}} \right)^2$$

thus:

$$Z_{LV} = Z_{HV} \left( \frac{U_{LV}}{U_{HV}} \right)^2$$

This formula can be applied whatever the cable voltage level, i.e. even across several transformers in series.

Example (see Figure 4-6)

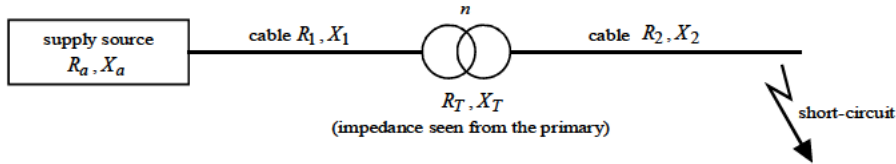


Figure 4-6: equivalent impedance of elements across a transformer

$n$  : transformation ratio

Impedance seen from the short-circuit perspective:

$$\sum R = R_2 + \frac{R_T}{n^2} + \frac{R_1}{n^2} + \frac{R_a}{n^2}$$

$$\sum X = X_2 + \frac{X_T}{n^2} + \frac{X_1}{n^2} + \frac{X_a}{n^2}$$

#### 4.2.1.2. Impedance of parallel links

If the fault current flows through two parallel links with impedances  $Z_1$  and  $Z_2$ , the equivalent impedance is:

$$Z_{eq} = \frac{Z_1 Z_2}{Z_1 + Z_2}$$

If impedances  $Z_1$  and  $Z_2$  are different, a complex numerical calculation should then be made.

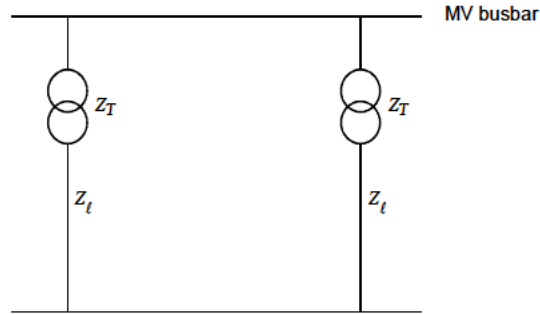
If:

$$Z_1 = Z_2$$

then:

$$Z_{eq} = \frac{Z_1}{2} = \frac{Z_2}{2}$$

*Example (see Figure 4-7)*



**Figure 4-7:** equivalent impedance of two identical parallel links

$Z_T$  : impedance of transformers seen by the secondary

$Z_l$  : impedance of links

The total impedance  $Z_{eq}$  is:

$$Z_{eq} = \frac{Z_T + Z_l}{2}$$

For  $n$  parallel links of the same impedance  $Z$ ,  $Z_{eq} = \frac{Z}{n}$ .

#### 4.2.1.3. Expression of impedances as a percentage and short-circuit voltage as a percentage

##### **Transformers**

Instead of giving the impedance value of transformers in ohms, the manufacturer gives the short-circuit voltage  $U_{sc}$  expressed as a percentage.

This short-circuit voltage represents the primary voltage which, when applied to the secondary short-circuited transformer, gives a current equal to the nominal current.

Thus:

$$\frac{U_{sc} (\%)}{100} V_n = Z I_n$$

hence:

$$Z = \frac{U_{sc} (\%) V_n}{100 I_n}$$

$V_n$ : single-phase nominal voltage

Transformer manufacturers give the apparent nominal power  $S_n$  in kVA:

$$S_n = 3 V_n I_n$$

$$Z = \frac{U_{sc} (\%) 3V_n^2}{100 S_n}$$

$$Z = \frac{U_{sc} (\%) U_n^2}{100 S_n}$$

$U_n$ : phase-to-phase nominal voltage =  $\sqrt{3} V_n$

Note: for transformers fitted with tap changers, the voltage  $U_n$  is that obtained for the main position of the changer (see IEC 60909, section 8.3.2.2).

### **Rotating machines**

Instead of giving the characteristic impedance values ( $X_d$ ,  $X_d'$ ,  $X_d''$ ) of motors and generators in ohms, manufacturers give them as a percentage ( $X_d$  (%),  $X_d'$  (%),  $X_d''$  (%)). By definition, the following relation applies:

$$X(\Omega) = \frac{X(\%) V_n}{100 I_n}$$

Manufacturers of rotating machines give the apparent nominal power  $S_n$  in kVA:

$$S_n = 3 V_n I_n$$

$$X(\Omega) = \frac{3V_n^2}{S_n} \frac{X(\%)}{100}$$

$$X(\Omega) = \frac{U_n^2}{S_n} \frac{X(\%)}{100}$$

$U_n$ : nominal phase-to-phase voltage

Thus:

$$X_d (\Omega) = \frac{U_n^2}{S_n} \frac{X_d (\%)}{100}$$

$$X'_d (\Omega) = \frac{U_n^2}{S_n} \frac{X'_d (\%)}{100}$$

$$X''_d (\Omega) = \frac{U_n^2}{S_n} \frac{X''_d (\%)}{100}$$

#### 4.2.1.4. Impedance values of different network elements

##### **Upstream network impedance**

Knowledge of the upstream network is generally limited to the indications supplied by the utility, i.e., the short-circuit power  $S_{sc}$  (in MVA) only:

$$Z_a = \frac{U_n^2}{S_{sc}}$$

$U_n$ : network nominal phase-to-phase voltage

The upstream network is generally considered to be a pure reactance, i.e.  $Z_a \cong X_a$ .

We saw in section 4.1.1 that the ratio  $\frac{R_a}{X_a}$  is between 0.05 and 0.3 for MV.

Let us take, for example  $\frac{R_a}{X_a} = 0.3$ , thus:

$$Z_a^2 = R_a^2 + X_a^2 = \left( (0.3)^2 + 1 \right) X_a^2 = 1.09 X_a^2$$

hence:

$$X_a = 0.96 Z_a$$

As a first approximation, we shall thus take  $Z_a = X_a$ .

Note: the approximation  $Z_a = X_a$  is better the lower the ratio  $\frac{R_a}{X_a}$  is.

**Generator power supply impedance**

In section 4.1.2, we saw that the short-circuit current developed in the following three periods:

- i) subtransient ( $X_d''$ ): lasting 10 to 20 ms after the start of the fault;
- ii) transient ( $X_d'$ ): lasting up to 100 to 400 ms;
- iii) synchronous ( $X_d$ ): synchronous reactance to be considered after the transient period;

– To check electrodynamic stress, the maximum short-circuit current is calculated on the basis of the subtransient reactance:

$$I_{sc3} = \frac{U_n}{\sqrt{3} X_d''}$$

$U_n$  : nominal phase-to-phase voltage

– To check heat stress in equipment, the maximum short-circuit current is calculated on the basis of the transient reactance:

$$I_{sc3} = \frac{U_n}{\sqrt{3} X_d'}$$

– To set the threshold of phase overcurrent protective devices, notably when the generator is able to operate cut-off from the utility network, the minimum short-circuit current (see section 4.4.2) is calculated on the basis of the transient reactance and the negative sequence reactance  $X_{(2)}$  (see section 4.2.2.1).

$$I_{sc2,\min} = \frac{U_n}{X_d' + X_{(2)}}$$

The steady state is not generally taken into account, assuming that the protective devices switch the current during the transient state or that the short-circuit current is held at  $3 I_n$  (see section 4.1.2). The protection threshold is therefore set below this value. If this is not the case, restrained voltage overcurrent protection is used (see section 7.24):

– To determine the breaking capacity of low voltage circuit-breakers, the maximum short-circuit current is calculated on the basis of the subtransient

reactance  $I_{sc3} = \frac{U_n}{\sqrt{3} X_d''}$ . It is generally lower than the short-circuit current supplied

by the utility.

– To determine the breaking capacity of high voltage circuit-breakers, the periodic component value and the aperiodic component value must be calculated

during the minimum opening time of the circuit-breaker, to which is added a half period of the rated frequency. These values must be passed on to the manufacturer for approval or tests (see section 8.2).

*Standard generator subtransient, transient, synchronous and negative-sequence impedance values (Tables 4-7, 4-8 and 4-9)*

S (kVA)	75	200	400	800	1,600	2,500
$X_d''$ (%)	10.5	10.4	12.9	10.5	18.8	19.1
$X_d'$ (%)	21	15.6	19.4	18	33.8	30.2
$X_d$ (%)	280	291	358	280	404	292
$X_{(2)}$ (%)	13.1	11.3	15.1	11.7	22.2	21.2

**Table 4-7:** subtransient, transient, synchronous and negative-sequence impedances of Leroy-Somer four-pole generators with a phase-to-phase voltage of 400 V and frequency of 50 Hz

S (kVA)	2,200	2,800	3,500
$X_d''$ (%)	15.5	14	13
$X_d'$ (%)	25.5	24.5	23
$X_d$ (%)	235	230	225
$X_{(2)}$ (%)	17	15.5	14.5

**Table 4-8:** subtransient, transient, synchronous and negative-sequence impedances of Leroy-Somer four-pole generators with a phase-to-phase voltage of 6 kV and frequency of 50 Hz

S (kVA)	1,500	2,500	3,250
$X_d''$ (%)	15.5	14.5	14
$X_d'$ (%)	27.5	26.5	25.5
$X_d$ (%)	255	255	250
$X_{(2)}$ (%)	17.5	16.5	16

**Table 4-9:** subtransient, transient, synchronous and negative-sequence impedances of Leroy-Somer four-pole generators with a phase-to-phase voltage of 11 kV and frequency of 50 Hz



Note: the resistance of the windings is negligible compared with the reactance  $R \ll X_d$ ,  $R \ll X_d'$  and  $R \ll X_d''$ .

### **Transformer impedances**

This is calculated using the short-circuit voltage  $U_{sc}$  expressed as a percentage and indicated on the transformer rating plate (see section 4.2.1.3).

$$Z_T = \frac{U_{sc}}{100} \frac{U_n^2}{S_n}$$

$U_n$ : no-load phase-to-phase voltage of the transformer  
 $S_n$ : apparent power of the transformer

If  $U_n$  is taken to be the primary voltage of the transformer, its impedance detected by the primary is found, and if  $U_n$  is taken to be the no-load secondary voltage of the transformer, its impedance detected by the secondary is found (see section 4.2.1.1).

In general:

$$R_T \ll X_T.$$

For MV/LV transformers,  $\frac{R_T}{X_T}$  is approximately 0.3, thus:

$$Z_T^2 = X_T^2 + R_T^2 = X_T^2 + (0.3)^2 X_T^2 = 1.09 X_T^2$$

hence:

$$X_T = 0.96 Z_T.$$

As a first approximation, we shall consider that  $Z_T = X_T$ .

Note: for HV/MV transformers,  $\frac{R_T}{X_T}$  is approximately 0.05, thus  $Z_T \cong X_T$ .

The internal impedance of a transformer is therefore often considered to be a pure reactance.

For 100 to 3,150 kVA France Transfo liquid-insulated MV/LV transformers, the short-circuit voltages are given in Table 4-10.

For 160 to 2,000 kVA France Transfo TRIHAL type dry-insulated transformers, the short-circuit voltage is 6% (see Table 4-11).

kVA rating	100	160	250	315	400	500	630	800	1,000	1,250	1,600	2,000	2,500	3,150
$U_{sc}$ (%)	4	4	4	4	4	4	4	4.5	5	5.5	6	6.5	7	7
Losses due to the load at 75°C (w)	2,100	2,350	3,250	3,900	4,600	5,500	6,500	10,200	12,100	15,000	18,100	22,000	28,000	33,000
$R_T$ (mΩ)	35.30	15.43	8.74	6.61	4.83	3.7	2.75	2.68	2.03	1.61	1.19	0.92	0.75	0.56
$X_T$ (mΩ)	57.23	39.10	25.44	20.30	16.10	12.93	10.31	9.07	8.16	7.22	6.19	5.38	4.65	3.70
$Z_T$ (mΩ)	67.24	42.03	26.90	21.35	16.81	13.45	10.67	9.46	8.41	7.40	6.30	5.46	4.71	3.74

**Table 4-10:** electrical characteristics of France Transfo liquid-insulated MV/LV transformers for a nominal voltage  $U_n = 410V$

kVA rating	160	250	400	630	800	1,000	1,250	1,600	2,000
$U_{sc}$ (%)	6	6	6	6	6	6	6	6	6
Losses due to the load at 75°C (w)	2,300	3,400	4,800	6,800	8,200	9,600	11,500	13,900	16,000
$R_r$ (mΩ)	15.10	9.14	5.04	2.88	2.15	1.61	1.24	0.91	0.67
$X_r$ (mΩ)	63.04	40.34	25.22	16.01	12.61	10.09	8.07	6.30	5.04
$Z_r$ (mΩ)	61.20	39.29	24.71	15.75	12.43	9.86	7.97	6.23	5.00

**Table 4-11:** electrical characteristics of TRIHAL dry-insulated MV/LV transformers for a nominal voltage  $U_n = 410V$

Note 1: when  $n$  equal transformers are in parallel, the value of the equivalent impedance is that of a transformer divided by  $n$ .

$$Z_{eq} = \frac{Z_T}{n}$$

If the transformers are not equal, the impedance of each transformer in parallel must be considered. For example, for two transformers:

$$Z_{eq} = \frac{Z_{T1} Z_{T2}}{Z_{T1} + Z_{T2}}$$

Note 2: the value of the transformer resistance  $R_T$  is determined by the Joule losses or copper losses due to the load, indicated on the rating plate. The value  $X_T$  is thereby deduced. Knowing the value  $R_T$  is especially important for small transformers,  $R_T$  is thus approximately  $X_T$  and  $Z_T \neq X_T$ .

$$Loss = 3 R_T I_n^2$$

$$R_T = \frac{Loss}{3 I_n^2}$$

$$R_T = \frac{U_n^2}{S_n^2} \times Loss$$

thus:

$$X_T = \sqrt{Z_T^2 - R_T^2}$$

### **Impedance of links**

*Resistance of overhead lines, cables and busbars*

This is easily calculated using the following formula:

$$R = \frac{\rho L}{S}$$

$L$ : length of the link in m

$S$ : cross-section of the conductor in mm<sup>2</sup>

$\rho$ : resistivity of the conductor material

In order to take into account the temperature of the conductor material during the short-circuit, the resistivity  $\rho$  is taken to be equal to:

– 1.25 times the resistivity of the conductors at 20°C when calculating the maximum short-circuit currents, i.e. 0.0225  $\Omega \text{ mm}^2/\text{m}$  for copper and 0.036  $\Omega \text{ mm}^2/\text{m}$  for aluminum.

– 1.5 times the resistivity of the conductors at 20°C when calculating the minimum short-circuit currents, i.e. 0.027  $\Omega \text{ mm}^2/\text{m}$  for copper and 0.043  $\Omega \text{ mm}^2/\text{m}$  for aluminum.

#### *Reactance of overhead lines*

The reactance per unit of length of overhead lines is approximately that of a vacuum:

$$\mu_0 \omega \left( \mu_0 = 4 \pi \times 10^{-7} \right).$$

The following values should be used:

- $X = 0.3 \Omega/\text{km}$  for LV and MV lines;
- $X = 0.4 \Omega/\text{km}$  for HV lines.

#### *Reactance of cables*

The reactance of cables is calculated using the following formula:

$$X = \left[ 0.0157 + 0.144 \text{Log} \left( \frac{d}{r} \right) \right] \text{ in } \Omega/\text{km}$$


$d$ : average distance between conductors

$r$ : radius of conductive cores


Log: decimal logarithm

The values to be used are:

– For low voltage:

– 0.08  $\Omega/\text{km}$  for three-core cables 

– 0.09  $\Omega/\text{km}$  for single-core flat  or triangular  cable bundles

– 0.15  $\Omega/\text{km}$  for single-core cables with  $d = 8r$  spacing 

– For medium and high voltage:

– 0.1 to 0.15  $\Omega/\text{km}$ .

*Busbar reactance*

For busbars, the value to be used is:  $0.15 \times 10^{-3} \Omega/m$ .

4.2.1.5. *Contribution of motors to the short-circuit current value*

When a short-circuit occurs, the motors feed the fault for a period corresponding to the flux clearance. The currents supplied by the motors are added to the current supplied by the source. The short-circuit current value is the algebraic sum of the currents supplied by the motors and sources (the phase angles between the currents are neglected and the algebraic sum maximizes the current value).

**Synchronous motors**

These contribute to the short-circuit current value in the same way as the generators since, upon occurrence of a short-circuit, they work as a generator. They are therefore equivalent to a voltage source with an internal impedance  $X'_d$  or  $X''_d$  (see section 4.2.1.4, “generator power supply impedance”).

**Asynchronous motors**

When a short-circuit occurs, these motors have a current that decreases fairly rapidly, with a time constant of approximately:

- 10 ms for single-cage motors up to 100 kW;
- 20 ms for double-cage motors and motors over 100 kW;
- 30 to 50 ms for very big slip ring rotor motors (1,000 kW).

They are equivalent to a voltage source to which a transient impedance  $X'_M$  is attributed, equal to the start-up impedance:

$$X'_M = \frac{U_n^2}{P} \frac{I_n}{I_{st}} \eta \cos \varphi$$

where:

$$P = S \eta \cos \varphi \quad \text{and} \quad X'_M (\%) = \frac{S}{U_n^2} X'_M (\Omega) \times 100 \quad (\text{see section 4.2.1.3})$$

$$\text{Hence: } X'_M (\%) = \frac{I_n}{I_{st}} \times 100$$

$\eta$  : motor efficiency

$\cos \varphi$ : motor power factor

- $\frac{I_n}{I_{st}}$  : ratio of the rated current to the motor start-up current  
 $P$  : mechanical power supplied by the motor  
 $S$  : apparent power of the motor ( $S = \sqrt{3}U_n I_n$ )

In the absence of more accurate information, we may take  $\eta \cos \varphi = 0.8$  and  $\frac{I_{st}}{I_n} = 6$ , which gives us  $X'_M = 17\%$ .

The large number of LV motors in industrial networks and the difficulty of knowing the average number of motors in service and the link impedances to be taken into account make it difficult to calculate the contribution of motors.

This is why it is usual to consider an overall motor contribution to the short-circuit current. This equivalent current is taken to be equal to three times the sum of the nominal currents of all the motors installed, each current being recalculated for the voltage level considered.

#### 4.2.1.6. Example of a symmetrical three-phase short-circuit calculation

Let us take an 11 kV utility network which supplies an MV/LV substation via a 1.5 km overhead line. The substation has two 1,000 kVA transformers in parallel which feed the main low voltage switchboard (MLVS).

A secondary LV switchboard feeds five 50 kW motors, all connected via identical cables. They are all operating when the fault appears.

The installation diagram is shown in Figure 4-8. We shall calculate the value of the symmetrical three-phase short-circuit current at different points in the installation, i.e.:

- at A on the MV busbar;
- at B on the MLVS 10 m from the transformers;
- at C on the secondary LV switchboard feeding the motors;
- at D at the terminals of a motor.

Next, we shall calculate the motor return current at points D, C, B and A.

In Table 4-12, we determine the values of reactances  $X$  and resistances  $R$  of each electrical element, at their supply voltage level. To determine the value of an impedance across a transformer, it must be multiplied by the square of the voltage ratio (see section 4.2.1.1).

upstream network:

$$U_n = 11 \text{ kV}$$

$$S_{sc} = 200 \text{ MVA}$$

$$\frac{R}{X} = 0.3$$

1.5 km overhead link  $3 \times 95 \text{ mm}^2$   
copper

two 1,000 kVA transformers

$$11 \text{ kV} / 400 \text{ V} \Rightarrow n = 27.5$$

$$U_{sc} = 5\%$$

busbar: three  $400 \text{ mm}^2$  copper bus sections  
length: 10 m

link 1:  
 $3 \times 400 \text{ mm}^2$  aluminum, single-core  
flat cable bundles  
length: 80 m

link 2:  $3 \times 25 \text{ mm}^2$  copper, three-  
core cables

length: 30 m

five 50 kW motors

$$\frac{I_{st}}{I_n} = 6$$

$$\eta \cos \phi = 0.8$$

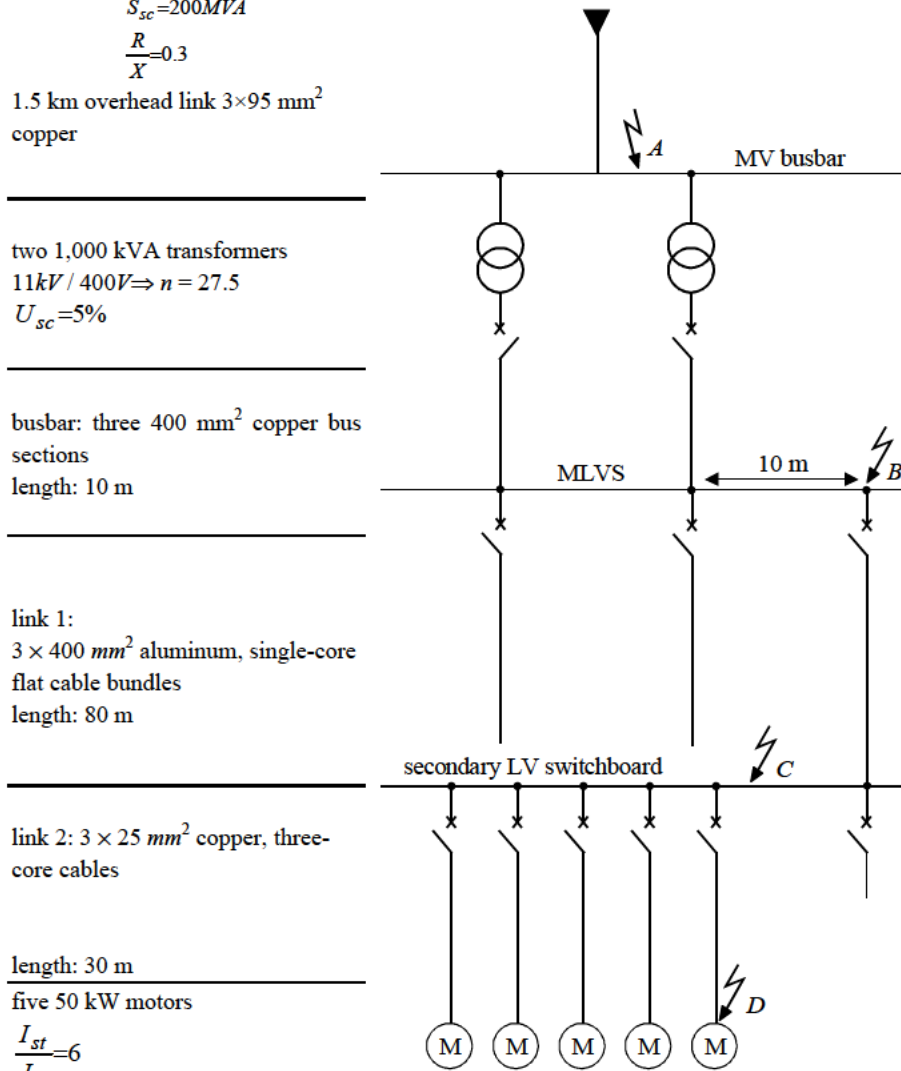


Figure 4-8: installation diagram for the symmetrical three-phase short-circuit calculation example



Element	Calculations	$X (\Omega)$ , Ref.	$R (\Omega)$ , Ref.
<b>Upstream</b>	$Z = \frac{(11 \times 10^3)^2}{200 \times 10^6} = 0.605$ $X = 0.96 Z$ $R = 0.3 X$	0.58 ①	0.17 ②
<b>Overhead line</b>	$X = 1.5 \times 0.3$ $R = \frac{0.0225 \times 1,500}{95}$	0.45 ③	0.36 ④
<b>Two transformers in parallel</b>	$X = \frac{8.16}{2} \times 10^{-3} \text{ see Table 4-10}$ $R = \frac{2.03}{2} \times 10^{-3}$	$4.08 \times 10^{-3}$ ⑤(*)	$1.015 \times 10^{-3}$ ⑥(*)
<b>Busbar</b>	$X = 0.15 \times 10^{-3} \times 10$ $R \text{ negligible}$	$1.5 \times 10^{-3}$ ⑦	$\cong 0$ ⑧
<b>Link 1</b>	$X = 0.15 \times 10^{-3} \times 80$ $R = \frac{0.036 \times 80}{400}$	$12 \times 10^{-3}$ ⑨	$7.2 \times 10^{-3}$ ⑩
<b>Link 2</b>	$X = 0.08 \times 10^{-3} \times 30$ $R = \frac{0.0225 \times 30}{25}$	$2.4 \times 10^{-3}$ ⑪	$27 \times 10^{-3}$ ⑫
<b>50 kW motors</b>	$X'_M = \frac{(400)^2}{50 \times 10^3} \times \frac{0.8}{6}$	0.427 ⑬	$R \cong 0$ ⑭

(\*) These values correspond to the transformer impedances detected by the LV side.

**Table 4-12:** values of reactances  $X$  and resistances  $R$  of each element

**Calculating the symmetrical three-phase short-circuit current***Fault at A on the MV busbar*

$$X_A = \textcircled{1} + \textcircled{3} = 0.58 + 0.45 = 1.03 \Omega$$

$$R_A = \textcircled{2} + \textcircled{4} = 0.17 + 0.36 = 0.53 \Omega$$

$$Z_A = \sqrt{(1.03)^2 + (0.53)^2} = 1.16 \Omega$$

$$I_{sc,A} = \frac{11,000}{\sqrt{3} \times 1.16} = 5,475 \text{ A}$$

Let us determine the short-circuit current peak value (see section 4.1.1):

$$\frac{R_A}{X_A} = \frac{0.53}{1.03} = 0.51$$

hence:

$$K_A = \sqrt{2} (1 + e^{-0.51\pi}) = 1.7$$

$$\hat{I}_{sc,A} = 1.7 \times 5,475 = 9,308 \hat{A}$$

*Fault at B on the MLVS*

The impedances calculated in MV must be recalculated for LV:

$$X_B = \frac{X_A}{n^2} + \textcircled{5} + \textcircled{7} = \frac{1.03}{(27.5)^2} + (4.08 + 1.5) \times 10^{-3} = 6.94 \times 10^{-3} \Omega$$

$$R_B = \frac{R_A}{n^2} + \textcircled{6} + \textcircled{8} = \frac{0.53}{(27.5)^2} + (1.015 + 0) \times 10^{-3} = 1.72 \times 10^{-3} \Omega$$

$$Z_B = \sqrt{(6.94)^2 + (1.72)^2} \times 10^{-3} = 7.15 \times 10^{-3} \Omega$$

$$I_{sc,B} = \frac{400}{\sqrt{3} \times 7.15 \times 10^{-3}} = 32,300 \text{ A}$$

Let us determine the short-circuit current peak value (see section 4.1.1):

$$\frac{R_B}{X_B} = \frac{1.72}{6.94} = 0.25$$

hence:

$$K_B = \sqrt{2} (1 + e^{-0.25\pi}) = 2.06$$

$$\hat{I}_{sc,B} = 2.06 \times 32,300 = 66,538 \hat{A}$$

*Fault at C on the secondary LV switchboard*

$$X_C = X_B + \textcircled{9} = (6.94 + 12) \times 10^{-3} = 18.94 \times 10^{-3} \Omega$$

$$R_C = R_B + \textcircled{10} = (1.72 + 7.2) \times 10^{-3} = 8.92 \times 10^{-3} \Omega$$

$$Z_C = \sqrt{(18.94)^2 + (8.92)^2} \times 10^{-3} = 20.94 \times 10^{-3} \Omega$$

$$I_{sc,C} = \frac{400}{\sqrt{3} \times 20.94 \times 10^{-3}} = 11029 \text{ A}$$

Let us determine the short-circuit current peak value (see section 4.1.1):

$$\frac{R_C}{X_C} = 0.47$$

hence:

$$K_C = \sqrt{2} (1 + e^{-0.47 \pi}) = 1.74$$

$$\hat{I}_{sc,C} = 1.74 \times 11,029 = 19,190 \hat{A}$$

*Fault at D at the terminals of a motor*

$$X_D = X_C + \textcircled{11} = (18.94 + 2.4) \times 10^{-3} = 21.34 \times 10^{-3} \Omega$$

$$R_D = R_C + \textcircled{12} = (8.92 + 27) \times 10^{-3} = 35.92 \times 10^{-3} \Omega$$

$$Z_D = \sqrt{(21.34)^2 + (35.92)^2} \times 10^{-3} = 41.78 \times 10^{-3} \Omega$$

$$I_{sc,D} = \frac{400}{\sqrt{3} \times 41.78 \times 10^{-3}} = 5,528 \text{ A}$$

Let us determine the short-circuit current peak value (see section 4.1.1):

$$\frac{R_D}{X_D} = 1.68$$

hence:

$$K_D = \sqrt{2} (1 + e^{-1.68 \pi}) = 1.42$$

$$\hat{I}_{sc,D} = 1.42 \times 5,528 = 7,850 \hat{A}$$

Note: the coefficient  $K$  characterizes the ratio of the peak current to the steady-state current. For an identical voltage level, it gradually decreases as the fault point moves away from the source:

$$K_D < K_C < K_B$$

The aperiodic component is thus greater when the fault point is near the transformer.

**Calculating the return current of motors (see section 4.2.1.5)**

Motors are considered to be independent sources. The return current of the motors is thus equal to the sum of currents supplied by each motor.

*Fault at D at the terminals of a motor*

Contribution of the motor at the terminal at which the fault occurs:

$$X_{D,mf} = \textcircled{13}$$

$$R_{D,mf} = \textcircled{14} \cong 0$$

$$I_{D,mot,f} = \frac{400}{\sqrt{3} \times 0.427} = 541 \text{ A}$$

Contribution of the other four motors:

$$X_{D,mi} = \textcircled{13} + 2 \times \textcircled{11} = 432 \times 10^{-3} \Omega$$

$$R_{D,mi} = \textcircled{14} + 2 \times \textcircled{12} = 54 \times 10^{-3} \Omega$$

$$Z_{D,mi} = \sqrt{(432)^2 + (54)^2} \times 10^{-3} = 0.435 \Omega$$

$$I_{D,mot,i} = 4 \times \frac{400}{\sqrt{3} \times 0.435} = 2124 \text{ A}$$

The short-circuit current supplied by the five motors is:

$$I_{D,mot} = I_{D,mot,f} + I_{D,mot,i} = 2,665 \text{ A}$$

For a short-circuit at D, the contribution of the five motors to the short-circuit current is:

$$\frac{I_{D,mot}}{I_{sc,D}} = 48\%$$

*Fault at C on the secondary LV switchboard*

$$X_{C,m} = X_{D,m} + \textcircled{11} = 0.427 + 2.4 \times 10^{-3} = 0.429 \Omega$$

$$R_{C,m} = R_{D,m} + \textcircled{12} = 0 + 27 \times 10^{-3} = 27 \times 10^{-3} \Omega$$

$$Z_{C,m} = \sqrt{(0.429)^2 + (27 \times 10^{-3})^2} = 0.430 \Omega$$

The short-circuit current supplied by the five motors is:

$$I_{C,mot} = 5 \times \frac{400}{\sqrt{3} \times 0.430} = 2,685 A$$

For a short-circuit at C, the contribution of the five motors to the short-circuit current is:

$$\frac{I_{C,mot}}{I_{sc,C}} = 24\%$$

*Fault at B on the MLVS*

$$X_{B,m} = X_{C,m} + \textcircled{9} = 0.429 + 12 \times 10^{-3} = 0.441 \Omega$$

$$R_{B,m} = R_{C,m} + \textcircled{10} = (27 + 7.02) \times 10^{-3} = 34.02 \times 10^{-3} \Omega$$

$$Z_{B,m} = \sqrt{(0.441)^2 + (34.02 \times 10^{-3})^2} = 0.442 \Omega$$

The short-circuit current supplied by the 5 motors is:

$$I_{B,mot} = 5 \times \frac{400}{\sqrt{3} \times 0.442} = 2,612 A$$

For a short-circuit at B, the contribution of the 5 motors to the short-circuit current is:

$$\frac{I_{B,mot}}{I_{sc,B}} = 8\%$$

*Fault at A on the MV busbar*

The impedances calculated for LV must be recalculated for MV:

$$X_{A,m} = n^2 X_{B,m} + n^2 \textcircled{5} = (27.5)^2 \times (0.441 + 4.08 \times 10^{-3}) = 337 \Omega$$

$$R_{A,m} = n^2 R_{B,m} + n^2 \textcircled{6} = (27.5)^2 \times (34.02 + 1.015) \times 10^{-3} = 26.5 \Omega$$

$$Z_{A,m} = \sqrt{(337)^2 + (26.5)^2} = 338 \Omega$$

The short-circuit current supplied by the five motors is:

$$I_{A,mot} = 5 \times \frac{11,000}{\sqrt{3} \times 338} = 94 \text{ A}$$

For a short-circuit at A, the contribution of the five motors to the short-circuit current is:

$$\frac{I_{A,mot}}{I_{sc,A}} = 1.7\%$$

The contribution of the LV motors can in general be neglected for a short-circuit on the MV side. On the other hand, for LV, it may be great and must therefore be taken into account when choosing switching devices and protection settings.

#### 4.2.2. Solid phase-to-earth short-circuit (zero fault impedance)

This is the fault shown in Figure 3-1. The fault current value is strongly influenced by the earthing system (see section 4.3).

The method for calculating the phase-to-earth short-circuit is more complex than that of symmetrical three-phase short-circuits.

Indeed, the dissymmetrical nature of currents  $I_1 = I_{sc}$  and  $I_2 = I_3 = 0$  means that an equivalent single-phase diagram can no longer be used. This is due to the mutual cable-to-cable and cable-to-earth impedances which are no longer balanced.

The calculation method used is the symmetrical component method.

#### *Calculating using the symmetrical component method*

This consists of breaking down an unbalanced three-phase system into the sum of three balanced three-phase systems: positive-sequence, negative-sequence and zero-sequence (see Figure 4-9).

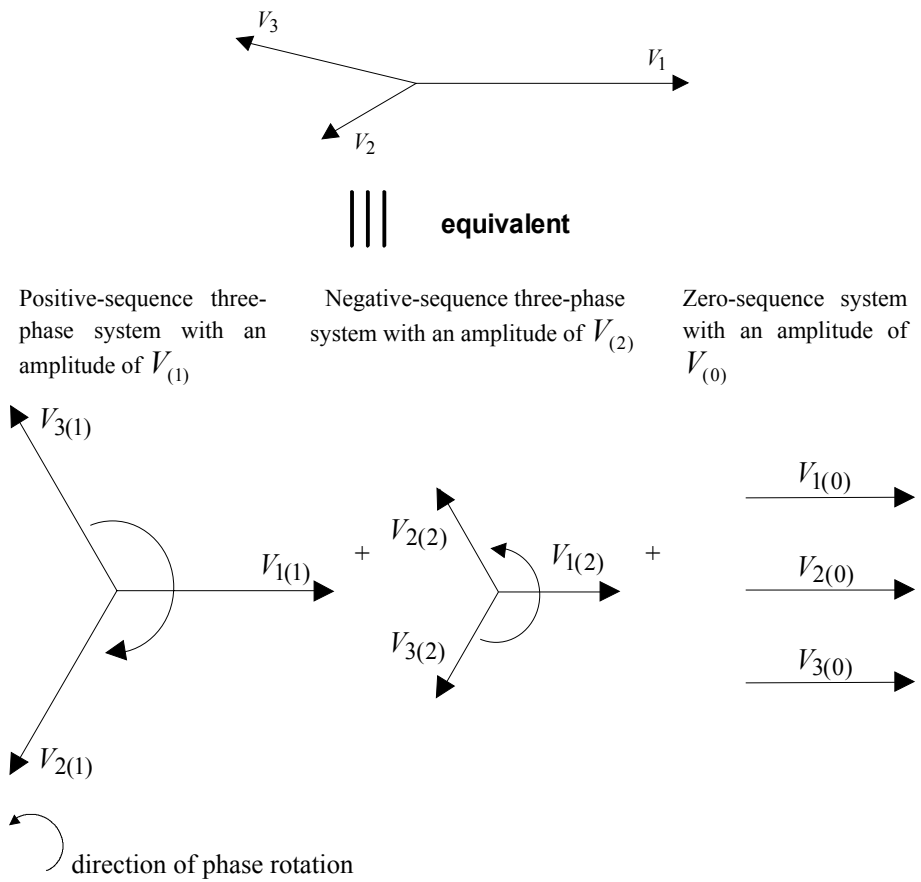
For example, for a solid phase-to-earth fault on phase 1, at the fault location:  $V_1 = 0$ ,  $V_2 \neq 0$  and  $V_3 \neq 0$ .

*The positive-sequence system* is the “normal” system comprising three equivalent voltages  $120^\circ$  out of phase clockwise:  $V_{1(1)}$ ,  $V_{2(1)}$  and  $V_{3(1)}$ .

*The negative-sequence system* is the system comprising three equivalent voltages  $120^\circ$  out of phase anti-clockwise:  $V_{1(2)}$ ,  $V_{2(2)}$  and  $V_{3(2)}$ .

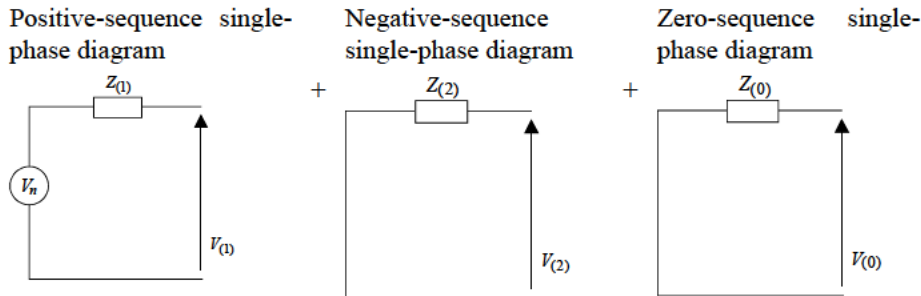
The zero-sequence system is the system comprising three equivalent phase-to-earth voltages with no phase angle:  $V_{1(0)}$ ,  $V_{2(0)}$  and  $V_{3(0)}$ .

*Unbalanced three-phase system*



**Figure 4-9:** breakdown of an unbalanced three-phase system into the sum of three balanced three-phase systems: positive-sequence, negative-sequence and zero-sequence

The network is therefore equivalent to the sum of three single-phase systems (see Figure 4-10).



**Figure 4-10:** equivalent network positive, negative and zero-sequence single-phase diagrams

$V_n$ : single-phase network voltage

$V_{(1)}$ ,  $V_{(2)}$ ,  $V_{(0)}$ : voltages of the three positive, negative and zero-sequence systems

$Z_{(1)}$ ,  $Z_{(2)}$ ,  $Z_{(0)}$ : equivalent impedances in positive, negative and zero-sequence systems, referred to as positive, negative and zero-sequence impedance.

Note: the supply source is a positive-sequence three-phase system and it therefore appears as the voltage source of the positive-sequence single-phase system. The negative and zero-sequence single-phase systems do not *a priori* have a voltage source.

Impedances  $Z_{(1)}$ ,  $Z_{(2)}$ ,  $Z_{(0)}$  are the values given by manufacturers (cables, lines, transformers, generators, etc.) and the utility.

Furthermore, in spite of the rather abstract nature of the method of calculation, these impedances can be easily measured and have a concrete physical nature:

– To measure *the positive-sequence impedance* of an electrical element (cable, transformer, rotating machine, etc.), a positive-sequence three-phase voltage system is applied to the terminals of the three phases and the current is then measured.

– To measure *the negative-sequence impedance* of an electrical element (cable, transformer, rotating machine, etc.), a negative-sequence three-phase voltage system is applied to the terminals of the three phases and the current is then measured.

– To measure *the zero-sequence impedance* of an electrical element (cable, transformer, rotating machine, etc.), a phase-to-earth voltage is applied to the terminals of the three cables in parallel and the current is then measured.

The method of calculation used to determine the phase-to-earth short-circuit current value is fairly long and complex, we shall therefore deal only with the result.



The *phase-to-earth short-circuit* current value is:

$$I_{sc0} = \frac{3V_n}{Z_{(1)} + Z_{(2)} + Z_{(0)}}$$

$V_n$ : single-phase network voltage

$$Z_{(1)} = \sqrt{(\sum R_{(1)})^2 + (\sum X_{(1)})^2}$$

$$Z_{(2)} = \sqrt{(\sum R_{(2)})^2 + (\sum X_{(2)})^2}$$

$$Z_{(0)} = \sqrt{(\sum R_{(0)})^2 + (\sum X_{(0)})^2}$$

$Z_{(1)}$ ,  $Z_{(2)}$ ,  $Z_{(0)}$  are the impedances equivalent to the positive, negative and zero-sequence impedances through which the short-circuit current flows

$X_{(1)}$ ,  $X_{(2)}$ ,  $X_{(0)}$  are the positive, negative and zero-sequence reactances of each electrical element

$R_{(1)} = R_{(2)} = R_{(0)}$  are the positive, negative and zero-sequence resistances of each electrical element and are always equal

#### 4.2.2.1. *Positive, negative and zero-sequence impedance values of different network elements*

##### **General note on positive-sequence impedances**

$Z_{(1)}$  is the positive-sequence impedance of a network element and it corresponds to the impedance measured when a positive-sequence three-phase voltage system is applied (voltage system under normal conditions) to this element. It is the same as the impedance  $Z_{sc}$  of the element when a symmetrical three-phase short-circuit occurs (a positive-sequence three-phase voltage system is applied upon occurrence of a symmetrical three-phase short-circuit).

$$\text{Result: } Z_{(1)} = Z_{sc}$$

for any type of equipment other than a rotating machine for which transient phenomena modify  $Z_{(1)}$  (see section 4.1.2).

##### **General note on negative-sequence impedances**

The symmetrical nature of cables, lines and transformers leads to the negative-sequence impedance being equal to the positive-sequence impedance for this equipment.

$$\text{Result: } Z_{(2)} = Z_{(1)} = Z_{sc}$$

for cables, transformers, lines and loads without motors, i.e. for all equipment other than rotating machines.

**Positive, negative and zero-sequence impedance of rotating machines**

The resistance is negligible compared with the reactance ( $R \ll X$ ) for different positive, negative and zero-sequence impedances of rotating machines.

*Synchronous machines (generators and large motors sometimes)*

– Positive-sequence: this is equal to the short-circuit impedance defined in section 4.2.1.4, i.e.  $X_d$ ,  $X'_d$  or  $X''_d$  depending on the short-circuit period considered (see Tables 4-7, 4-8 and 4-9).

– Negative-sequence: the magnetic field produced by a negative-sequence three-phase system of current rotates in the opposite direction to that of the machine. The negative-sequence impedance is the actual reactance of the inductive circuit, i.e.  $Z_{(2)} \approx X''_d$  (see Tables 4-7, 4-8 and 4-9).

– Zero-sequence: when a zero-sequence three-phase voltage system is applied to a stator, the flux induced in the rotor is zero (since there is no rotating field). This impedance only depends therefore on the stator winding, is thus low and considered to be a pure reactance (see Tables 4-13, 4-14 and 4-15 giving the standard zero-sequence impedance values).

S (kVA)	75	200	400	800	1,600	2,500
$X_{(0)}$ (%)	10	2.5	3.7	3	3.7	9.1

**Table 4-13:** zero-sequence impedances of Leroy-Somer four-pole generators with a phase-to-phase voltage of 400 V and frequency of 50 Hz

S (kVA)	2,200	2,800	3,500
$X_{(0)}$ (%)	7.5	6.5	6

**Table 4-14:** zero-sequence impedances of Leroy-Somer four-pole generators with a phase-to-phase voltage of 6 kV and frequency of 50 Hz

S (kVA)	1,500	2,500	3,250
$X_{(0)}$ (%)	7.5	7	6.5

**Table 4-15:** zero-sequence impedances of Leroy-Somer four-pole generators with a phase-to-phase voltage of 11 kV and frequency of 50 Hz

Note: when a phase-to-earth short-circuit occurs, it is important to know whether the machine is earthed or unearthed in order to determine the zero-sequence impedance of the generator together with the neutral earthing impedance  $Z_{tog}$ :

- when the neutral is directly earthed  $Z_{tog} = j X_{(0)}$ ;
- when the neutral is earthed via an impedance  $Z_N$ ,  $Z_{tog} = 3Z_N + j X_{(0)} \cong 3Z_N$ , as generally  $X_{(0)} \ll Z_N$ ;
- when the neutral is unearthed  $Z_{tog} = \infty$ .

Impedance  $Z_N$  is multiplied by a factor of 3. This is explained in the note in the paragraph on “zero-sequence impedance of transformers” below.

#### ***Asynchronous machines (usually motors)***

- Positive-sequence: this is equal to the short-circuit impedance defined in section 4.2.1.4, i.e. a transient impedance  $X'_M$  of the order of 10 to 20%.

$$Z_{(1)} = X'_M$$

- Negative-sequence: this is not very different from the positive-sequence impedance.

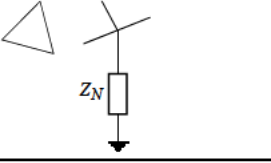
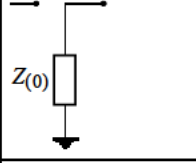
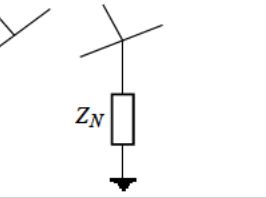
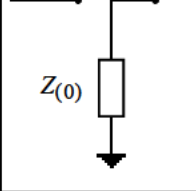
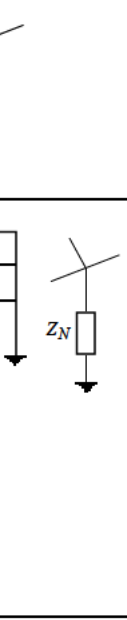


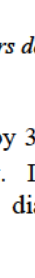

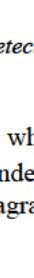

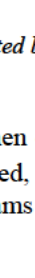
$$Z_{(2)} = Z_{(1)} = X'_M$$

- Zero-sequence: as for synchronous motors, this impedance only depends on the stator winding and is thus low. For zero-sequence calculations, it is not used since the motor neutral is usually unearthed. It therefore appears as infinite. When the motor is fed by a delta-connected secondary transformer, limiting resistance earthing can be made at the point where the stator neutral is located (if it is star-connected). The motor zero-sequence impedance is therefore equal to three times the limiting resistance.

#### ***Zero-sequence impedance of transformers***

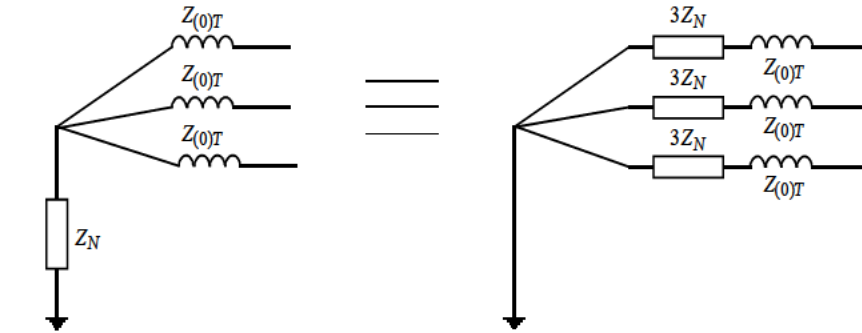
The zero-sequence impedance of transformers depends on whether it is possible to reclose earth fault currents.

Table 4-16 indicates the zero-sequence impedance of transformers detected by the secondary in relation to the coupling method.

Transformer coupling	Zero-sequence impedance detected by the secondary	Equivalent diagram
	$Z_{(0)} = Z_{(1)} + 3Z_N$ if $Z_N = 0$ (directly earthed neutral, then $Z_{(0)} = Z_{(1)}$ )	
	$Z_{(0)} = 10Z_{(1)} + 3Z_N$ for a driven flux transformer (which is generally the case) if $Z_N = 0$ (directly earthed neutral), then $Z_{(0)} = 10Z_{(1)}$	
	$Z_{(0)} = Z_{(1)} + 3Z_N$ in the case where the network upstream of the transformer has an earthed neutral allowing the primary earth current to be reclosed.  <i>Important:</i> in this case, with the primary and secondary neutrals being earthed, there is no galvanic insulation between the primary and secondary. The overvoltages thus spread through the transformer.	
	$Z_{(0)} = \infty$	
	$Z_{(0)} = \infty$	
	$Z_{(0)} = \infty$	

**Table 4-16:** zero-sequence impedance of transformers detected by the secondary

Note: the earthing impedance  $Z_N$  is multiplied by 3 when calculating the zero-sequence impedance detected by the secondary. Indeed, the zero-sequence impedance is determined for a phase and the two diagrams in Figure 4-11 are equivalent.



$Z_{(0)T}$  : transformer zero-sequence impedance  
 $3Z_N$  : the neutral earthing zero-sequence impedance

**Figure 4-11:** neutral earthing zero-sequence impedance

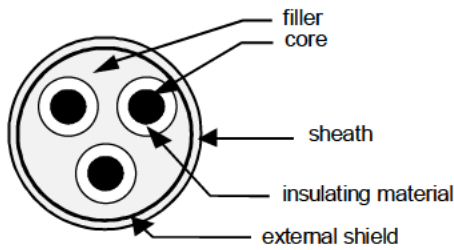
**Zero-sequence reactance of cables**

- In MV and HV, this is more or less equal to three times the positive-sequence impedance  $X_{(0)} \approx 3 X_{(1)}$  in MV and HV.
- In LV, it is approximately  $X_{(1)}$ , and  $X_{(0)} = X_{(1)}$  is used for the calculations.

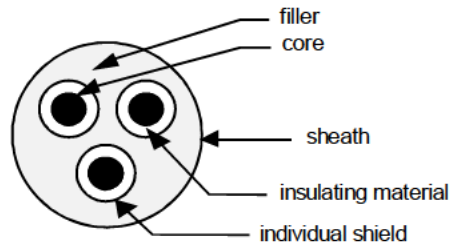
**Zero-sequence capacitance of cables**

This is difficult to determine as it depends on numerous parameters such as the type of insulating material, the voltage, the cable cross-section, and whether the cable is individually or collectively shielded.

A cable is said to be collectively shielded when the shield surrounds all the conductors (see Figure 4-12), and to be individually shielded when each conductor is surrounded by a shield (see Figure 4-13). A single-core armored cable is obviously individually shielded.



**Figure 4-12:** collectively shielded cable



**Figure 4-13:** individually shielded cable

The capacitance of *individually shielded* cables is given in the following formula:

$$C = \frac{\mathcal{E}_r}{18Ln\left(\frac{D}{d}\right)} \quad \text{in } \mu\text{F} / \text{km}$$

$\mathcal{E}_r$  : relative permittivity of the insulating material

$D$  : insulating material diameter under the external shield

$d$  : shield diameter

$Ln$  : naperian logarithm

The relative permittivity values of the main insulating materials are given in Table 4-17.

type of insulating material	PE	PR	EPR	PVC
$\mathcal{E}_r$	2.3	2.5	2.8	6

**Table 4-17:** relative permittivity of insulating materials

Tables 4-18 and 4-19 give the approximate values in  $\mu\text{F}/\text{km}$  for individually EPR or PE shielded cables.

<b>kV rating</b>			
<b>cross-section mm<sup>2</sup></b>	5.5	10	20
35	0.29	0.21	\
70	0.35	0.26	0.17
120	0.44	0.31	0.20
240	0.58	0.41	0.26

**Table 4-18:** capacitance of individually EPR shielded cables in  $\mu\text{F}/\text{km}$

kV rating			
cross-section mm <sup>2</sup>	5.5	10	20
35	0.27	0.17	\
70	0.34	0.21	0.14
120	0.42	0.26	0.17
240	0.54	0.34	0.21

**Table 4-19:** capacitance of individually PE shielded cables in  $\mu\text{F}/\text{km}$

#### **Collectively shielded cables**

There is no simple formula that can be used to determine the capacitances of *collectively shielded* cables. As an example, for SILEC cables the following applies:

- PR insulated low voltage cables
  - 16 mm<sup>2</sup>  $\Rightarrow C = 0.2 \mu\text{F}/\text{km}$
  - 35 mm<sup>2</sup>  $\Rightarrow C = 0.16 \mu\text{F}/\text{km}$
- PVC insulated 3.2 kV phase-to-phase cables
  - 10 mm<sup>2</sup>  $\Rightarrow C = 0.16 \mu\text{F}/\text{km}$
  - 25 mm<sup>2</sup>  $\Rightarrow C = 0.18 \mu\text{F}/\text{km}$
  - 35 mm<sup>2</sup>  $\Rightarrow C = 0.17 \mu\text{F}/\text{km}$
- PVC insulated 6 kV phase-to-phase cables
  - 16 mm<sup>2</sup>  $\Rightarrow C = 0.14 \mu\text{F}/\text{km}$
  - 50 mm<sup>2</sup>  $\Rightarrow C = 0.21 \mu\text{F}/\text{km}$
  - 95 mm<sup>2</sup>  $\Rightarrow C = 0.30 \mu\text{F}/\text{km}$

*In practice*, to assess the maximum value of capacitive currents when the type of each cable is not known (which is generally the case), a maximum value of  $0.5 \mu\text{F}/\text{km}$  can be taken.

#### **Zero-sequence reactance of overhead lines**

The zero-sequence reactance of overhead lines is more or less equal to three times the positive-sequence reactance:

$$X_{(0)} \approx 3 X_{(1)}$$

**Zero-sequence capacitance of overhead lines**

This is approximately 5 nF/km. It is therefore much lower than the capacitance of cables (100 times lower).

**Zero-sequence impedance of the utility**

This is directly related to the utility's earthing system:

- if the neutral is earthed via a Petersen coil, the zero-sequence impedance is considered to be infinite since the earth fault current is zero (see section 4.3.3);
- if the neutral is directly earthed, the zero-sequence impedance is more or less equal to the positive-sequence impedance (except if the HV/MV transformer primary is star-connected and unearthed) (see Table 4-16);
- if the neutral is earthed via a resistance, the zero-sequence impedance is more or less equal to three times this resistance since the transformer and link impedances are negligible compared with the limiting resistance. Figure 4-11 explains the presence of the factor 3:

$$Z_{(0)} = 3Z_N$$

**French example**

- For an overhead network, the zero-sequence current is limited to  $I_\ell = 300 \text{ A}$ . If the phase-to-phase voltage is  $U_n = 20 \text{ kV}$ , then:

$$Z_{(0)} = 3Z_N$$

where  $Z_N = \frac{U_n}{\sqrt{3}I_\ell}$

hence:

$$Z_{(0)} = 3 \times \frac{20,000}{\sqrt{3}} \times \frac{1}{300} = 115 \Omega$$

- For an underground network, the zero-sequence current is limited to  $I_\ell = 1,000 \text{ A}$ . If the phase-to-phase voltage is  $U_n = 20 \text{ kV}$ , then:

$$Z_{(0)} = 3Z_N$$

where  $Z_N = \frac{U_n}{\sqrt{3}I_\ell}$



hence:

$$Z_{(0)} = 3 \times \frac{20,000}{\sqrt{3}} \times \frac{1}{1,000} = 35 \Omega$$

#### 4.2.3. *The phase-to-phase short-circuit clear of earth*

The phase-to-phase short-circuit clear of earth is shown in Figure 3-2.

This is a dissymmetrical fault. The symmetrical component method must be used as for the phase-to-earth fault.

For a fault between phases 2 and 3:

$$I_2 = I_3 = \frac{\sqrt{3}V_n}{Z_{(1)} + Z_{(2)}}$$

$Z_{(1)}$ ,  $Z_{(2)}$  are the impedances equivalent to the sum of all the positive and negative-sequence impedances through which the fault current flows.

If there is no generator:

$$Z_{(1)} = Z_{(2)}$$

and

$$I_2 = I_3 = \frac{\sqrt{3}V_n}{2Z_{(1)}}$$

#### 4.2.4. *The two-phase-to-earth short-circuit*

The two-phase-to-earth short-circuit is shown in Figure 3-3.

It is a dissymmetrical fault. The symmetrical component method must be used as for the phase-to-earth fault.

For a fault between phases 2 and 3:

$$I_2=I_3=\frac{\sqrt{Z_{(2)}^2+Z_{(0)}Z_{(2)}+Z_{(0)}^2}}{Z_{(1)}Z_{(2)}+Z_{(2)}Z_{(0)}+Z_{(0)}Z_{(1)}}\sqrt{3}V_n$$

$Z_{(1)}$ ,  $Z_{(2)}$ ,  $Z_{(0)}$  are the impedances equivalent to the sum of all the positive, negative and zero-sequence impedances through which the fault current flows.

If there is no generator:

$$Z_{(1)} = Z_{(2)}$$

and

$$I_2=I_3=\frac{\sqrt{Z_{(1)}^2+Z_{(0)}Z_{(1)}+Z_{(0)}^2}}{Z_{(1)}^2+2Z_{(1)}Z_{(0)}}\sqrt{3}V_n$$

### 4.3. Circulation of phase-to-earth fault currents

Let us consider a low or medium voltage three-phase network (see Figure 4-14). The neutral may or may not be earthed. The earthing system depends on the value of the earthing impedance  $Z_N$ .

As indicated in Table 2-1:

- if  $Z_N$  is approximately zero (several milliohms), the neutral is directly earthed;
- if  $Z_N$  is very high, which may even include no connection between the neutral and earth, the neutral is unearthed or highly impedant;
- if  $Z_N$  is different from zero, but of low value (several tenths to several hundredths of ohms depending on the voltage level and the type of network), the network is said to have *limiting impedance earthing*.
- $Z_N$  may be a resistance, a fixed reactance or a variable reactance (Petersen coil).

In the absence of a fault, a balanced three-phase current circulates in the network's capacitances and the symmetrical nature of these currents leads to zero current in the neutral earthing.

When a phase is put in contact with earth, a current  $I_f$  is established between the faulty phase and earth. We can see that it is reclosed by impedance  $Z_N$  as well as the phase-earth capacitances of the healthy phases (see Figure 4-14):

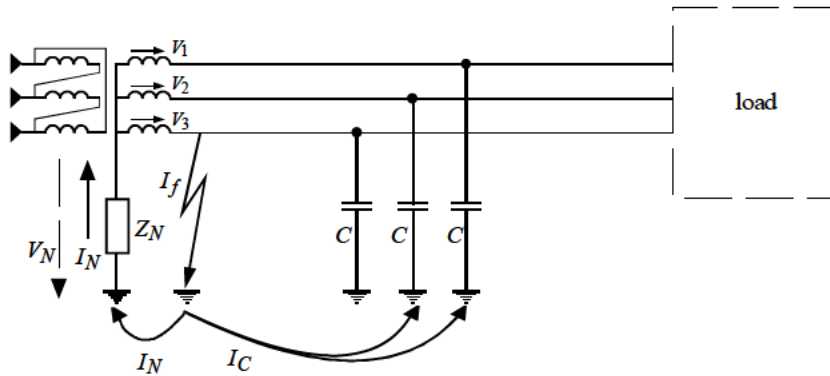
$$I_f = I_C + I_N$$

where:

$I_C$  : current reclosing via the phase-earth capacitance of the healthy phases

$I_N$  : current reclosing via the neutral earthing impedance

$I_f$  : current circulating in the fault



$C$  : phase-earth capacitance of a phase

$I_C$  : current reclosing via the phase-earth capacitances of healthy phases

$I_N$  : current reclosing via the neutral earthing impedance

$I_f$  : current circulating in the fault

$V_N$  : neutral point voltage displacement

$Z_N$  : neutral earthing impedance

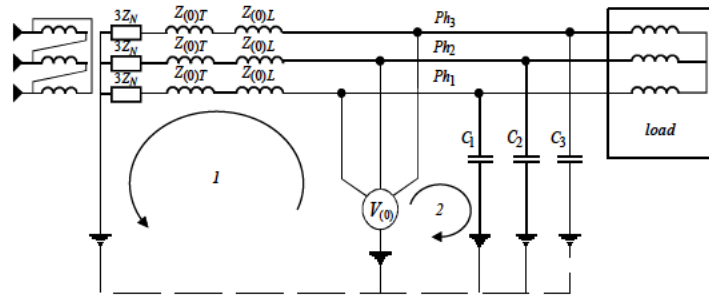
**Figure 4-14:** circulation of earth fault currents

In order to calculate these currents accurately, let us take once more the fault current expression using the symmetrical component method:

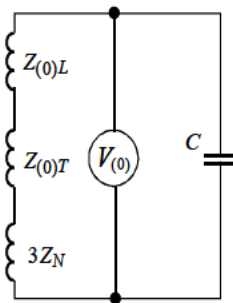
$$I_f = \frac{3V_n}{Z_{(1)} + Z_{(2)} + Z_{(0)}}$$

$$I_f = \frac{3V_n}{2Z_{(1)} + Z_{(0)}} \quad \text{if there is no generator } (Z_{(1)} = Z_{(2)})$$

To determine  $Z_{(0)}$ , the equivalent zero-sequence diagram seen from the fault point must be determined (see section 4.2.2). As we saw previously, the fault current recloses via the neutral earthing impedance and healthy phase capacitances. The equivalent diagram is therefore that in Figure 4-15.



Equivalent zero-sequence diagram:



$Z_N$ : neutral earthing impedance

$Z_{(0)L}$ : zero-sequence impedance of the link connecting the transformer to the fault point

$Z_{(0)T}$ : transformer zero-sequence impedance (see Table 4-16)

$C_1, C_2, C_3$ : phase-earth capacitances (or zero-sequence capacitances) equal to C

$V_{(0)}$ : zero-sequence voltage

1 and 2: circuits ensuring current circulation to earth

**Figure 4-15:** zero-sequence diagram of a network affected by a phase-earth fault

Note 1: the neutral earthing impedance is recalculated for each phase and must therefore be multiplied by factor of 3 (see Figure 4-11).

Note 2: the zero-sequence impedance upstream of the transformer is infinite, except in the case of a star-star transformer having an earthed neutral allowing primary earth current to be reclosed (see Table 4-16). In this case, the impedance must be taken into account by adding it in series to the equivalent zero-sequence diagram.

The zero-sequence impedance detected by the fault point is thus:

$$Z_{(0)} = (Z_{(0)L} + Z_{(0)T} + 3Z_N) // C$$

The symmetrical component method gives us:

$$V_{(0)} = \frac{Z_{(0)}}{Z_{(1)} + Z_{(2)} + Z_{(0)}} V_n$$

and

$$I_f = \frac{3V_n}{Z_{(1)} + Z_{(2)} + Z_{(0)}} \quad (\text{see section 4.2.2})$$

$V_n$  : single-phase network voltage

When the neutral is not directly earthed,  $Z_{(1)}$  and  $Z_{(2)}$  can be neglected compared with  $Z_{(0)}$  (neutral earthing impedance  $Z_N$  is largely preponderant):

thus:

$$V_{(0)} = V_n$$

and

$$I_f = \frac{3V_n}{Z_{(0)}}$$

We shall now study the phase-earth fault current value in relation to the earthing system, i.e. in relation to  $Z_N$ .

#### 4.3.1. *Unearthed or highly impedant neutral*

In this case  $Z_N \rightarrow \infty$  and  $Z_N \gg \frac{1}{jC\omega}$

thus

$$Z_{(0)} = \frac{1}{jC\omega} \quad (\text{see Figure 4-15})$$

hence

$$I_f = \frac{3V_n}{Z_{(0)}} = \frac{3V_n}{\left(\frac{1}{jC\omega}\right)}$$

$$I_f = 3jC\omega V_n$$

$C$  : network phase-earth capacitance

The fault current is therefore fairly small and only depends on the network phase-earth capacitance (or zero-sequence capacitance).

#### **Low voltage example**

For a low voltage cable, the phase-earth capacitance is  $\approx 0.25 \mu\text{F}/\text{km}$ .

For a 1 km network  $I_f = 3 \times 1 \times 0.25 \times 10^{-6} \times 100 \times \pi \times 230 = 0.054 \text{ A}$ .

This current is very small. It can be measured via the fault location systems based on a low frequency generator (see section 2.4.3).

#### **20 kV medium voltage example**

For a medium voltage cable, the phase-earth capacitance is  $\approx 0.5 \mu\text{F}/\text{km}$  (see section 4.2.2.1).

For a 10 km network  $I_f = 3 \times 10 \times 0.5 \times 10^{-6} \times 100 \times \pi \times \frac{20,000}{\sqrt{3}} = 54 \text{ A}$ .

This current is small enough not to be dangerous for the cables and transformers, although it can be prejudicial to rotating machines (see section 10.1.2).

#### **4.3.2. Impedance-earthed neutral (resistance or reactance)**

$Z_N$  is equal to several tenths to several hundredths of ohms. It is far higher than  $Z_{(0)T}$  and  $Z_{(0)L}$ , thus  $Z_{(0)T} + Z_{(0)L} \ll Z_N$ .

hence:

$$Z_{(0)} = 3Z_N // C = \frac{3Z_N}{1 + 3jC\omega Z_N} \quad (\text{see Figure 4-15})$$

and

$$I_f = \frac{3V_n}{Z_{(0)}} = 3V_n \left( \frac{1 + 3jC\omega Z_N}{3Z_N} \right)$$

$$I_f = \frac{V_n}{Z_N} + 3jC\omega V_n$$

$Z_N$  is called: *phase-earth short-circuit limiting impedance*.

$\frac{V_n}{Z_N}$  is generally limited to several tenths of amperes (see section 10.1.1).

As we saw for the case of the unearthed neutral (see section 4.3.1), the value  $3jC\omega V_n$  is negligible at low voltage ( $< 1$  A), although at high voltage the capacitive current value may be close to the limiting current  $\frac{V_n}{Z_N}$ , notably for widely spread networks.

This capacitive current is not dangerous for cables and transformers, although it may be prejudicial to rotating machines (see section 10.1.1). Furthermore, large capacitive currents may make the protective system more complex (see section 10.1.1).

Note: if neutral earthing is via a reactance  $Z_N = jL_N\omega$ , thus

$$I_f = V_n \left( 3jC\omega - \frac{1}{jL_N\omega} \right)$$

Whatever the network structure, care must be taken to make sure that:

$$3C\omega \neq \frac{1}{L_N\omega} \text{ applies,}$$

because in the case of equality the current is zero and the fault cannot be detected (this is the case of tuned reactance earthing) (see section 4.3.3).

### 4.3.3. Tuned reactance or Petersen coil earthing

The calculation hypotheses are identical in the case of impedance earthing, thus:

$$Z_{(0)L} + Z_{(0)T} \ll Z_N$$

hence:

$$I_f = \frac{V_n}{Z_N} + 3jC\omega V_n \quad (\text{see Figure 4-15})$$

where  $Z_N = jL_N\omega$  and  $L_N$ : earthing coil inductance.

thus:

$$I_f = jV_n \left( 3C\omega - \frac{1}{L_N\omega} \right)$$

The Petersen coil is a reactor allowing the fault current to be cleared. The following equation should therefore be respected as far as possible:

$$3C\omega = \frac{1}{L_N\omega} \Rightarrow I_f \cong 0$$

It is difficult to know the network capacitance precisely as it varies depending on the configuration of the network and extensions. It is therefore preferable to install a variable reactor to maintain equation  $3L_N C\omega^2 = 1$ .

In public distribution networks, the reactance is necessarily variable due to the multiple network configurations possible.

In practice, tuning is never entirely perfect and a current thus circulates while the fault lasts. This fault current may be maintained until the operating personnel intervenes (no switching upon occurrence of the first fault). Care must be taken to make sure that this current presents no danger to equipment or personnel (see section 2.2.2.5).

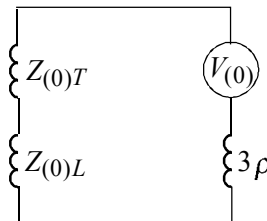
#### 4.3.4. Directly earthed neutral

In this case  $Z_N \cong 0$  and  $\frac{1}{jC\omega} \gg Z_{(0)T} + Z_{(0)L}$  (see Figure 4-15).

The capacitive current is negligible compared with the current circulating in the neutral.

The fault current is therefore only limited by the impedances of the transformer and links, and by fault resistance  $\rho$  which in this case is not negligible.

The equivalent zero-sequence diagram is shown in Figure 4-16.



$\rho$  : fault resistance

$Z_{(0)T}$  : transformer zero-sequence impedance

$Z_{(0)L}$  : zero-sequence impedance of the link connecting the transformer to the fault point

**Figure 4-16:** single-phase zero-sequence diagram when the neutral is directly earthed



The fault resistance is multiplied by a factor 3 because of the transformation of the three-phase diagram into a single-phase diagram. The demonstration is identical to that of the neutral earthing zero-sequence impedance (see Figure 4-11).

This therefore gives a very high phase-earth current, close to the three-phase short-circuit current, especially if the fault resistance  $\rho$  is low:

$$I_f = \frac{3V_n}{Z_{(1)} + Z_{(2)} + Z_{(0)T} + Z_{(0)L} + 3\rho} \quad (\text{see section 4.2.2})$$

$Z_{(1)}$  and  $Z_{(2)}$  are respectively the positive and negative-sequence impedances of the network upstream of the short-circuit. They are equal to the sum of the impedance of the link connecting the transformer to the fault point, the transformer impedance and the impedance of the network upstream of the transformer.

If there is no generator,  $Z_{(1)} = Z_{(2)}$  and  $I_f = \frac{3V_n}{2Z_{(1)} + Z_{(0)T} + Z_{(0)L} + 3\rho}$ .

Note: in the usual case of a delta-star transformer,  $Z_{(0)T}$  is equal to the positive-sequence impedance of the transformer (see Table 4-16). The zero-sequence impedance  $Z_{(0)L}$  of the link is generally close to the positive-sequence impedance.

If the impedance of the network upstream of the transformer is neglected, the fault current is:

$$I_f = \frac{3V_n}{3Z + 3\rho}$$

$$I_f = \frac{V_n}{Z + \rho}$$

where  $Z$  is equal to the sum of the impedance of the transformer and the link connecting the transformer to the fault point.

It can be seen therefore that the phase-to-earth short-circuit current value is close to the three-phase short-circuit current value.

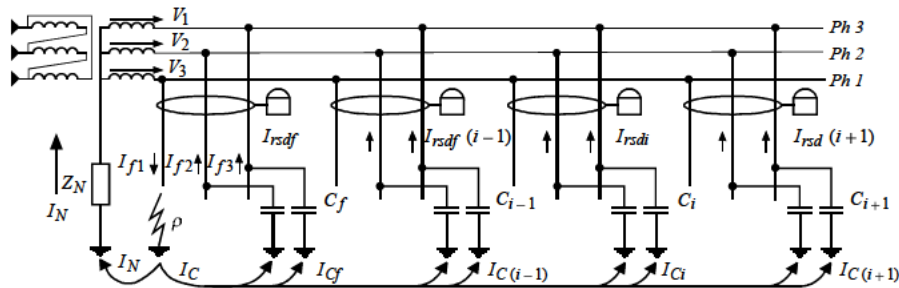
#### ***4.3.5. Spreading of the capacitive current in a network with several outgoing feeders upon occurrence of an earth fault***

As we saw in sections 4.3.1, 4.3.2 and 4.3.3, knowing the total value of the capacitive current is important (except in the case of direct neutral earthing). It is

moreover useful to know how it spread and how it is detected by the measuring apparatus of different outgoing feeders and of the earthing connection. Knowing the current values detected by the measuring apparatus is important for choosing earth fault protective devices and setting them.

Let us consider a low or medium voltage three-phase network made up of several outgoing feeders  $i - 1, i, i + 1$ , etc. (see Figure 4-17).

A residual current measuring device is installed on each outgoing feeder, it measures the vectorial sum of the currents circulating in each of the phases (see section 7.2). The residual current corresponds to the current flowing through earth.



- $I_{f1}$ : current circulating in the fault
- $I_N$ : current circulating in the neutral earthing impedance
- $I_C$ : capacitive current reclosing via the network phase-earth capacitance
- $I_{Cf}$ : capacitive current reclosing via the healthy phases of the faulty feeder
- $I_{Ci}$ : capacitive current reclosing via the healthy phases of the healthy feeders
- $I_{rsdf}$ : residual current measured on the faulty feeder
- $I_{rsdi}$ : residual currents measured on the healthy feeders
- $V_1, V_2, V_3$ : single network voltages

**Figure 4-17:** spread of the capacitive current in a network with several feeders

As we saw in section 4.3, the current flowing through the fault is the sum of the current reclosing via  $Z_N$  and reclosing via the capacitances of the healthy network phases.

When the network has several feeders (which is generally the case), the fault current recloses via the capacitance of the healthy phases of each feeder.

**Fault current value**

The value of the current in the fault is:

$$I_{f1} = \frac{V_n}{Z_N} + 3 j C \omega V_n$$

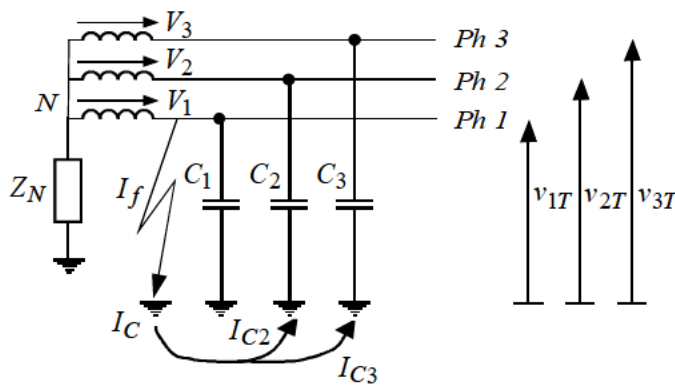
where:

$C$ : total capacitance of the network per phase =  $C_f + C_{i-1} + C_i + C_{i+1}$

$C_f$ : capacitance of the faulty feeder per phase

Note: in the case of an unearthed neutral  $I_{f1} = 3 j C \omega V_n$  since  $Z_N = \infty$ .

The capacitance per phase is multiplied by three. We shall now see why. Let us consider the diagram in Figure 4-18.



$$I_C = I_{C2} + I_{C3}$$

- $V_1, V_2, V_3$  : phase neutral voltages
- $v_{1T}, v_{2T}, v_{3T}$  : phase earth voltages
- $v_{NT}$  : neutral-to-earth voltage

**Figure 4-18:** value of the current reclosing via the healthy phase capacitances

When a solid phase-earth fault occurs, a phase-to-phase voltage appears on the two healthy phases:

$$v_{1T} = 0$$

$$v_{2T} = V_2 - V_1$$

$$v_{3T} = V_3 - V_1$$

The capacitive current value is:

$$I_C = I_{C2} + I_{C3}$$

where:

$$I_{C2} = j C \omega v_{2T} = j C \omega (V_2 - V_1)$$

$$I_{C3} = j C \omega v_{342T} = j C \omega (V_3 - V_1)$$

hence:

$$I_C = j C \omega (V_2 - V_1 + V_3 - V_1)$$

$$I_C = j C \omega (V_1 + V_2 + V_3 - 3V_1)$$

$$I_C = -3 j C \omega V_1$$

since:

$$V_1 + V_2 + V_3 = 0$$

$$|I_C| = 3 j C \omega V_n$$

***Value of the current detected by the residual current measuring device located on the faulty feeder***

The residual current in the faulty feeder is:

$$I_{rsdf} = I_{f1} + I_{f2} + I_{f3}$$

In the faulty feeder measuring device, the healthy phase capacitive currents  $I_{f2}$  and  $I_{f3}$  circulate in the opposite direction to the fault current  $I_{f1}$ ,  $I_{f2} + I_{f3} = -3j C_f \omega V_n$ .

The capacitive current detected by the measuring device is thus the sum of the network capacitive currents less the faulty feeder capacitive currents.

Hence:

$$I_{rsdf} = \frac{V_n}{Z_N} + 3 j (C - C_f) \omega V_n$$

where:

$$C : \text{total network capacitance} = C_f + C_{i-1} + C_i + C_{i+1}$$

$$C_f : \text{faulty feeder capacitance}$$

$$C - C_f = C_{i-1} + C_i + C_{i+1} \dots$$

We can see that if there is only one feeder, the residual current measuring device will not detect any capacitive current.

Note: in the case of an unearthed neutral  $I_{rsdf} = 3j(C - C_f)\omega V_n$  since  $Z_N = \infty$ .

***Value of the current detected by the residual current measuring devices located on the healthy feeders***

The residual current on the healthy feeders is:

$$I_{rsdi} = 3jC_i\omega V_n$$

$C_i$  : healthy feeder capacitance

A healthy feeder thus detects a current that is proportional to its capacitance. We can therefore see that a residual current measuring device will detect current in a healthy feeder.

If the protection setting threshold is not greater than this capacitive current, the healthy feeder may trip when a fault occurs on another feeder.

The way to overcome this problem is to install directional earth fault protection devices (see section 7.4).

#### **4.4. Calculation and importance of the minimum short-circuit current**

Whatever the type and location of short-circuit, the protection directly upstream of the short-circuit point must be activated by the minimum short-circuit current.

Knowing the minimum short-circuit current is therefore important for setting the current thresholds of protective devices. Furthermore, the switching device must open in a time compatible with the protection of persons and equipment.

The minimum short-circuit current must be calculated downstream of all the switching devices.

The procedure is carried out in the following steps:

– *Step 1*: determine the furthest point downstream of the switching device: load or switching device directly downstream.

- *Step 2*: determine the configuration upstream of the network leading to a minimum short-circuit:
  - determine the lowest short-circuit current supply source that can be configured in the network;
  - choose the configuration giving the longest link up to the source.
- *Step 3*: determine the type of short-circuit giving the lowest value.
- *Step 4*: determine the length of the longest fault loop.
- *Step 5*: calculate the short-circuit, e.g. using the impedance method or conventional method.

General note about the calculation: to calculate the minimum short-circuit current, the resistivity of the conductors is taken to be equal to 1.5 times the resistivity at 20°C, i.e. 0.027 Ω mm<sup>2</sup>/m for copper and 0.043 Ω mm<sup>2</sup>/m for aluminum (in order to take into account the influence of the temperature of the conductor core during the short-circuit).

#### **4.4.1. Calculating the minimum short-circuit current in low voltage in relation to the earthing system**

The minimum short-circuit current must be calculated downstream of all the protection devices (circuit-breakers or fuses) for TN and IT systems because they guarantee the protection of people.

For TT systems, protection of people is provided by residual current devices whose setting must satisfy the following condition (see IEC 60364-4-41, section 413.1.4.2):

$$R_A I_A \leq 50 V$$

$R_A$  : earth resistance of the exposed conductive parts

$I_A$  : rated residual current of the circuit-breaker

If selectivity is judged to be necessary, an operating time of the residual protection at the most equal to 1 second is admissible in distribution circuits.

To calculate the minimal short-circuit current, two methods can be applied:

- the impedance method which can be used when all the characteristics of the fault loop are known, including that of the supply source;
- the conventional method which can be used when neither the short-circuit current at the origin of the cable considered (at the location point of the switching device), nor the characteristics of the upstream power supply is known.

4.4.1.1. Calculating the minimum short-circuit current in a TN system

The procedure is carried out in the following steps:

Step 1: see section 4.4.

Step 2: see section 4.4.

Step 3: the type of short-circuit giving the lowest value is the phase-to-neutral short-circuit.

Step 4: the longest fault loop is the phase-to-neutral short-circuit at the location point of the load the furthest away (see Figure 4-19).

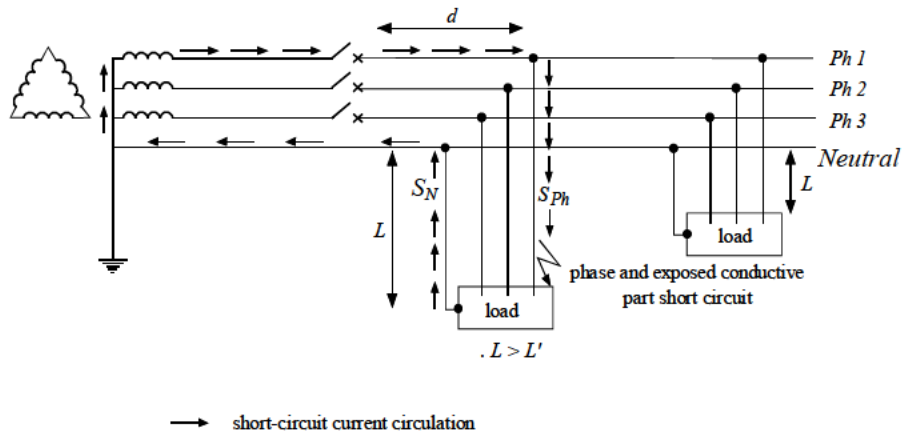


Figure 4-19: fault loop for a phase-to-neutral short-circuit in a TN system

$L$  is the longest circuit length from the circuit-breaker. We can see that the fault current flows through the phase along a length  $L$  and the neutral along a length  $L$ , then flows up to the source. The distance  $d$  of the circuit-breaker up to the circuit connection point is neglected.

Step 5: the short-circuit current is calculated.

**Impedance method**

We saw in section 4.2.2 that the single-phase short-circuit current value is:

$$I_{sc} = \frac{3V_n}{Z_{(\omega)} + Z_{(1)} + Z_{(2)}}$$

$V_n$  : single-phase voltage

- $Z_{(0)}$  : zero-sequence impedance  
 $Z_{(1)}$  : positive-sequence impedance  
 $Z_{(2)}$  : negative-sequence impedance

- if the network is not fed by a generator  $Z_{(1)} = Z_{(2)}$ ;
- if the network is fed by a generator  $Z_{(2)} < Z_{(1)}$ . Taking  $Z_{(2)} = Z_{(1)}$ ,  $I_{sc}$  is minimized. With the aim being to calculate the minimum short-circuit current, this approximation can be used, even when the network is fed by a generator;
- at low voltage,  $Z_{(0)}$  is close to  $Z_{(1)}$ ; as a first approximation we shall take  $Z_{(0)} = Z_{(1)}$ .

This gives us a simplified formula for  $I_{sc}$  :

$$I_{sc} = \frac{3V_n}{3Z_{(1)}} = \frac{V_n}{Z_{(1)}}$$

$Z_{(1)}$  being the positive-sequence impedance of the fault loop.

We may assume that impedance  $Z_r$  of the network upstream of the switching device  $Z_r = R_r + j X_r$  and impedance  $Z_N$  of the neutral upstream of the switching device  $Z_N = R_N + j X_N$  are known.

Let:

$L$  : length of the circuit in meters given in Figure 4-19

$S_{ph}$  : cross-section of the circuit phase conductors

$S_N$  : cross-section of the circuit neutral conductor

$\lambda$  : reactance per unit length of the conductors

$\rho$  : resistivity of the conductors equal to 1.5 times that of 20°C (which minimizes the short-circuit current)

The fault loop impedance is thus:

$$Z_{loop} = \sqrt{\left[ R_r + R_N + \rho L \left( \frac{1}{S_{ph}} + \frac{1}{S_N} \right) \right]^2 + [X_r + X_N + 2\lambda L]^2}$$



The minimum short-circuit current is:

$$I_{sc \min} = \frac{V_n}{Z_{loop}}$$

$V_n$ : single-phase no-load network voltage

### **Conventional method**

This method is not applicable to installations fed by a generator.

The short-circuit current value is given in the formula:

$$I_{sc \min} = \frac{0.8V_n}{\rho L \left( \frac{1}{S_{ph}} + \frac{1}{S_N} \right)}$$

$V_n$ : single-phase voltage in volts, during normal operation at the place where the switching device is installed

$L$ : length of the circuit in meters shown in Figure 4-19

$\rho$ : resistivity of the conductors equal to 1.5 times that at 20°C (which minimizes the short-circuit current)

$S_{ph}$ : cross-section of the circuit phase conductors

$S_N$ : cross-section of the circuit neutral conductor

This method uses the following simplifications:

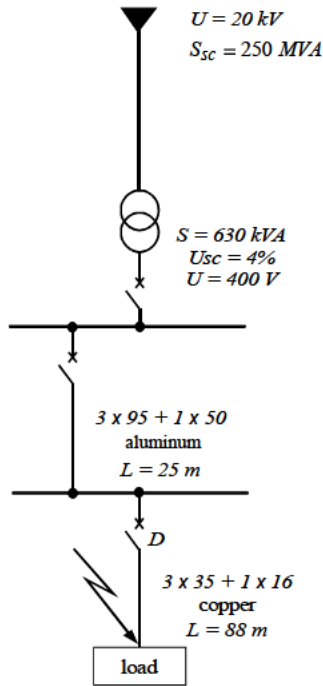
- it is assumed that in the event of a short-circuit, the voltage at the point where the protective device is located is equal to 80% of the rated voltage. In other words, it is assumed that the part of the fault loop upstream of the switching device represents 20% of the total impedance of the fault loop;

- the influence of the reactance of the conductors is negligible for cross-sections less than 150 mm<sup>2</sup>. The influence of conductor reactances is taken into account for large cross-sections by increasing the resistance by 15% for 150 mm<sup>2</sup> cross-sections, by 20% for 185 mm<sup>2</sup> cross-sections, by 25% for 240 mm<sup>2</sup> cross-sections and by 30% for 300 mm<sup>2</sup> cross-sections;

- the short-circuit is assumed to be solid, i.e. the arc resistances, contact and analogue resistances are not taken into account.

**Example**

Let us take the diagram in Figure 4-20, which corresponds to the configuration giving the lowest short-circuit current at the point where the load is located. We shall calculate the minimum short-circuit current at the location point of the load.



**Figure 4-20:** TN system minimum short-circuit current calculation example

*Impedance method*

– upstream network

$$Z_A = \frac{U^2}{S_{sc}} = \frac{(400)^2}{250 \times 10^6} = 0.64 \text{ m}\Omega$$

Let us assume that:

$$\frac{R_A}{X_A} = 0.2, \quad R_A^2 + X_A^2 = 0.04 X_A^2 + X_A^2 = Z_A^2$$

$$X_A = \frac{Z_A}{\sqrt{1.04}} = 0.63 \text{ m}\Omega$$

$$R_A = 0.13 \text{ m}\Omega$$

– 630 kVA transformer,  $U_{sc} = 4\%$  according to Table 4-10

$$Z_T = 10.67 \text{ m}\Omega$$

$$X_T = 10.31 \text{ m}\Omega$$

$$R_T = 2.75 \text{ m}\Omega$$

– cable  $3 \times 95 \text{ mm}^2 + 1 \times 50 \text{ mm}^2$  Alu

$$\text{phase: } R = \frac{0.043 \times 25}{95} = 11.32 \text{ m}\Omega$$

$$\text{neutral: } R_N = \frac{0.043 \times 25}{50} = 21.5 \text{ m}\Omega$$

Let us assume that the cable is three-core,  $X_\ell = 0.08 \text{ m}\Omega/\text{m}$  (see section 4.2.1.4):

$$\text{phase: } X = 0.08 \times 25 = 2 \text{ m}\Omega$$

$$\text{neutral: } X_N = 0.08 \times 25 = 2 \text{ m}\Omega$$

The impedance of the network upstream of circuit-breaker CB can thus be determined:

$$\text{phase: } R_r = 0.13 + 2.75 + 11.32 = 14.20 \text{ m}\Omega$$

$$X_r = 0.63 + 10.31 + 2 = 12.94 \text{ m}\Omega$$

$$\text{neutral: } R_N = 21.5 \text{ m}\Omega$$

$$X_N = 2 \text{ m}\Omega$$

For the cable downstream of circuit-breaker CB, in  $3 \times 35 \text{ mm}^2 + 16 \text{ mm}^2$  copper:

$$\rho = 27 \text{ m}\Omega \text{ mm}^2/\text{m}$$

$$S_{Ph} = 35 \text{ mm}^2$$

$$S_N = 16 \text{ mm}^2$$

Let us assume that the cable is three-core,  $X_\ell = 0.08 \text{ m}\Omega/\text{m}$ .

This results in:

$$Z_{loop} = \sqrt{\left[14.20 + 21.5 + 27 \times 88 \left(\frac{1}{35} + \frac{1}{16}\right)\right]^2 + [12.94 + 2 + 2 \times 0.08 \times 88]^2}$$

$$Z_{loop} = \sqrt{(252.1)^2 + (29.0)^2} = 254 \text{ m}\Omega$$

$$I_{sc \text{ min}} = \frac{230}{254 \times 10^{-3}} = 906 \text{ A}$$

*Conventional method*

$$I_{sc \text{ min}} = \frac{0.8 V_n}{\rho L \left(\frac{1}{S_{Ph}} + \frac{1}{S_N}\right)} = \frac{0.8 \times 230}{0.027 \times 88 \left(\frac{1}{35} + \frac{1}{16}\right)}$$

$$I_{sc \text{ min}} = 850 \text{ A}$$

We can see in this example that the conventional method reduces the result of the minimum short-circuit current calculation by 6%.

#### 4.4.1.2. Calculating the minimum short-circuit current in an IT system without a distributed neutral

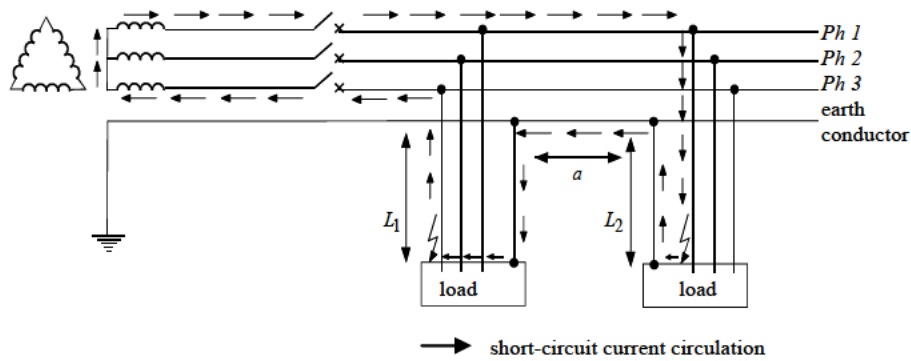
The procedure is carried out in the following steps:

Step 1: see section 4.4.

Step 2: see section 4.4.

Step 3: the type of short-circuit giving the lowest value is the double fault, the first being located in the phase of a circuit, the second being located in another phase of another circuit (see Figure 4-21). This is a phase-to-phase short-circuit clear of earth.

Step 4: the fault loop is longest for the double fault occurring at the two loads the furthest away from the switching devices (see Figure 4-21).



**Figure 4-21:** fault loop for a double fault on phases 1 and 3 in an IT system without a distributed neutral

$L_1$  and  $L_2$  are the lengths of the two loads furthest away from the circuit-breaker. We can see that the fault current flows through the following path:

- length  $L_2$  on phase 1
- length  $L_2$  on the earth conductor (PE)
- length  $L_1$  on the earth conductor (PE)
- length  $L_1$  on phase 3
- up to the source

Note: length “a” between the two connection points of the circuits is negligible.

Step 5: the short-circuit current is calculated.

#### **Impedance method**

We saw in section 4.2.3 that the current value of the phase-to-phase short-circuit clear of earth is:

$$I_{sc2} = \frac{\sqrt{3} V_n}{Z_{(1)} + Z_{(2)}}$$

$V_n$  : single-phase voltage

$Z_{(1)}$  : positive-sequence impedance

$Z_{(2)}$  : negative-sequence impedance

– if the network is not fed by a generator  $Z_{(1)} = Z_{(2)}$ ,

– if the network is fed by a generator,  $Z_{(2)} < Z_{(1)}$ .

Taking  $Z_{(2)} = Z_{(1)}$ ,  $I_{sc}$  is minimized. With the aim being to calculate a minimum short-circuit current, this approximation can be used, even when the network is fed by a generator.

Thus:

$$I_{sc2} = \frac{\sqrt{3}V_n}{2Z_{(1)}}$$

$2Z_{(1)}$  being the positive-sequence impedance of the fault loop (indeed, the fault loop represents the round trip of the short-circuit  $Z_{loop} = 2Z_{(1)}$ ).

It is assumed that the impedance  $Z_r$  of the network upstream of the switching device is known  $Z_r = R_r + jX_r$ .

Let:

- $L1$  and  $L2$  : circuit lengths shown in Figure 4-21
- $S_{ph}$  : cross-section of the circuit phase conductors
- $\lambda$  : reactance per unit length of the conductors
- $S_{PE}$  : cross-sectional area of the earth conductor
- $\rho$  : resistivity of the conductors equal to 1.5 times that at 20°C (which minimizes the short-circuit current)

The fault loop impedance is thus:

$$Z_{loop} = \sqrt{\left[ 2R_r + \left( \frac{\rho}{S_{ph}} + \frac{\rho}{S_{PE}} \right) (L1 + L2) \right]^2 + [2X_r + 2(L1 + L2)\lambda]^2}$$

The minimum short-circuit current is:

$$I_{sc2 \min} = \sqrt{3} \frac{V_n}{Z_{loop}}$$

$V_n$  : single-phase no-load network voltage

### **Conventional method**

This method cannot be applied in installations fed by a generator. The minimum short-circuit current is given in the formula:

$$I_{sc \min} = \frac{\sqrt{3} V_n \times 0.8}{L_1 \left( \frac{\rho_1}{S_{Ph1}} + \frac{\rho_1}{S_{PE1}} \right) + L_2 \left( \frac{\rho_2}{S_{Ph2}} + \frac{\rho_2}{S_{PE2}} \right)}$$

Assuming that  $L_1 = L_2 = L$ , where  $L$  is the maximum value of  $L_1$  and  $L_2$ , then:

$$I_{cc \min} = \frac{\sqrt{3} V_n \times 0.8}{2L\rho \left( \frac{1}{S_{ph}} + \frac{1}{S_{PE}} \right)}$$

$V_n$  : single voltage in volts, during normal operation at the place where the switching device is installed

$L$  : maximum length of lengths  $L_1$  and  $L_2$  shown in Figure 4-21

$\rho$  : resistivity of the conductors equal to 1.5 times that at 20°C (which minimizes the short-circuit current)

$S_{Ph}$  : cross-section of the circuit phase conductors

$S_{PE}$  : cross-section of the circuit earth conductor

This method uses the following simplifications:

– it is assumed that in the event of a short-circuit, the voltage at the point where the protective device is located is equal to 80% of the rated voltage. In other words, it is assumed that the part of the fault loop upstream of the switching device represents 20% of the total impedance of the fault loop;

– the influence of the reactance of the conductors is negligible for cross-sections less than 150 mm<sup>2</sup>. The influence of conductor reactances is taken into account for large cross-sections by increasing the resistance by 15% for 150 mm<sup>2</sup> cross-sections, by 20% for 185 mm<sup>2</sup> cross-sections, by 25% for 240 mm<sup>2</sup> cross-sections and by 30% for 300 mm<sup>2</sup> cross-sections.

– the short-circuit is assumed to be solid, i.e. the arc resistance, contact and analogue resistances are not taken into account.

**Example**

Let us consider the diagram in Figure 4-22, corresponding to the configuration giving the lowest short-circuit current at the point where the load is located. We shall calculate the minimum short-circuit current for a double fault, the first between a phase and the exposed conductive part at the point where load 1 is located, the second between another phase and the exposed conductive part at the point where load 2 is located.

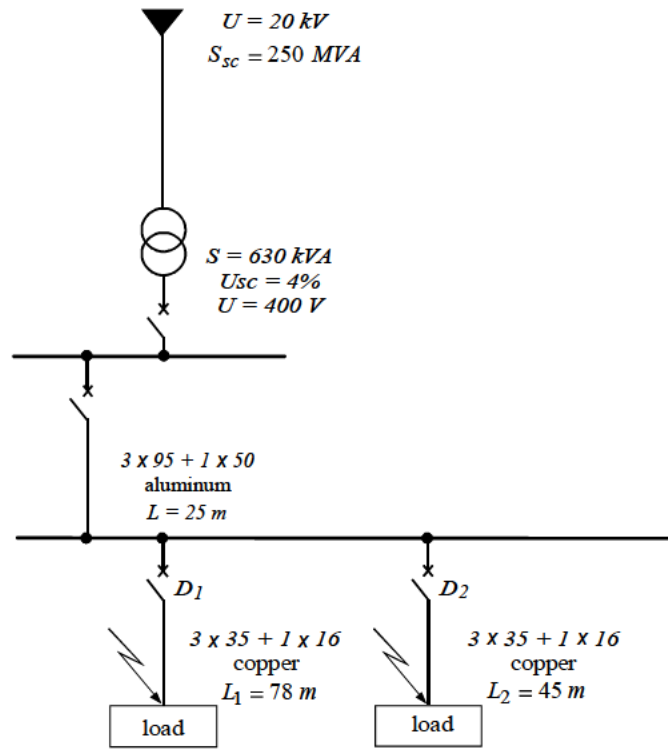


Figure 4-22: IT system without distributed neutral minimum short-circuit current calculation example

**Impedance method**

– upstream network

$$Z_A = \frac{U^2}{S_{sc}} = \frac{(400)^2}{250 \times 10^6} = 0.64 \text{ m}\Omega$$



Let us assume that:

$$\frac{R_A}{X_A} = 0.2, \quad R_A^2 + X_A^2 = 0.04 X_A^2 + X_A^2 = Z_A^2$$

$$X_A = \frac{Z_A}{\sqrt{1.04}} = 0.63 \text{ m}\Omega$$

$$R_A = 0.13 \text{ m}\Omega$$

– 630 kVA transformer,  $U_{sc}=4\%$  according to Table 4-10

$$Z_T = 10.67 \text{ m}\Omega$$

$$X_T = 10.31 \text{ m}\Omega$$

$$R_T = 2.75 \text{ m}\Omega$$

– cable  $3 \times 95 \text{ mm}^2 + 1 \times 50 \text{ mm}^2$  Alu

$$R = \frac{0.043 \times 25}{95} = 11.32 \text{ m}\Omega$$

Let us assume that the cable is three-core,  $X_\ell = 0.08 \text{ m}\Omega/\text{m}$  (see section 4.2.1.4):

$$X = 0.08 \times 25 = 2 \text{ m}\Omega$$

The impedance of the network upstream of circuit-breakers CB1 and CB2 can thus be determined:

$$R_r = 0.13 + 2.75 + 11.32 = 14.20 \text{ m}\Omega$$

$$X_r = 0.63 + 10.31 + 2 = 12.94 \text{ m}\Omega$$

For cables feeding loads 1 and 2, in  $3 \times 35 \text{ mm}^2 + 16 \text{ mm}^2$  copper:

$$\rho: 27 \text{ m}\Omega \text{ mm}^2/\text{m}$$

$$S_{ph}: 35 \text{ mm}^2$$

$$S_N: 16 \text{ mm}^2$$

Let us assume that the cable is three-core,  $X_\ell = 0.08 \text{ m}\Omega/\text{m}$ , thus:

$$Z_{loop} = \sqrt{\left[2 \times 14.20 + 27 \left(\frac{1}{35} + \frac{1}{16}\right) (78 + 45)\right]^2 + \left[2 \times 12.94 + 2 (78 + 45) \times 0.08\right]^2}$$

$$Z_{loop} = \sqrt{(330.8)^2 + (45.6)^2} = 334 \text{ m}\Omega$$

$$I_{sc2 \min} = \frac{230 \times \sqrt{3}}{334 \times 10^{-3}} = 1193 \text{ A}$$

**Conventional method**

$$I_{scb \min} = \frac{\sqrt{3} V_n \times 0.8}{(L_1 + L_2) \rho \left( \frac{1}{S_{Ph}} + \frac{1}{S_{PE}} \right)} = \frac{\sqrt{3} \times 230 \times 0.8}{(78 + 45) \times 0.027 \left( \frac{1}{35} + \frac{1}{16} \right)}$$

$$I_{sc2 \min} = 1054 \text{ A}$$

We can see in this example that the conventional method minimizes the result of the minimum short-circuit current calculation by 12%.

4.4.1.3. *Calculating the minimum short-circuit in an IT system with distributed neutral*

The procedure is carried out in the following steps:

- Step 1: see section 4.4.
- Step 2: see section 4.4.
- Step 3: the type of short-circuit giving the lowest value is the double fault, the first being located in the phase of a circuit, the second being located on the neutral of another circuit.
- Step 4: the fault loop is as long as in the IT system without distributed neutral, the only difference being that for the second fault, the short-circuit current flows through the neutral instead of a phase.
- Step 5:
  - the cross-section of the neutral conductor is less than or equal to the cross-section of a phase which thus minimizes the short-circuit current value in relation to the IT system without distributed neutral;
  - the voltage applied to the fault loop is a single voltage, as opposed to the case of the IT system without distributed neutral for which the voltage applied is a phase-to-phase voltage. The short-circuit current is thus limited to a factor  $\sqrt{3}$  in relation to the system without distributed neutral:

$$I_{sc2 \min} = \frac{V_n}{Z_{loop}}$$

To conclude, we thus have a minimum short-circuit current at least  $\sqrt{3}$  times lower than the minimum short-circuit current in the case of the IT system without distributed neutral.

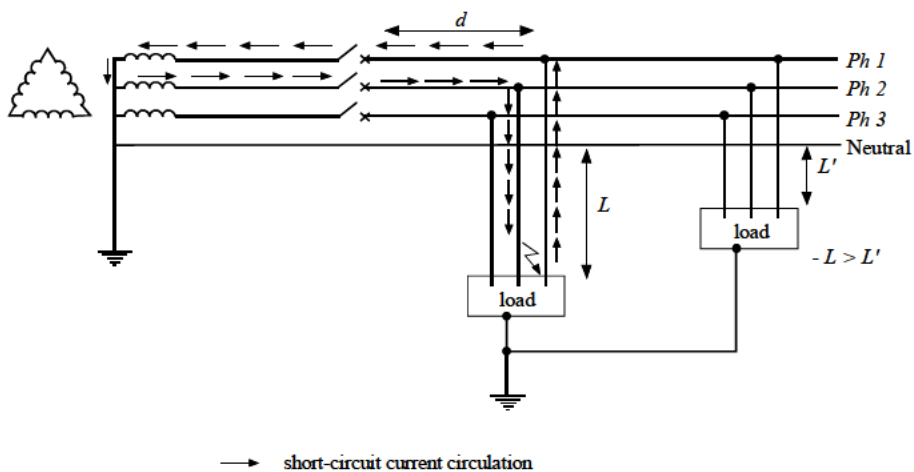
This means that smaller maximum circuit lengths must be used which is why it is preferable not to distribute the neutral in an IT system.

In the case where the length of the circuits does not ensure tripping upon occurrence of the second fault, residual current devices must be installed.

#### 4.4.1.4. Calculating the minimum short-circuit in a TT system

The procedure is carried out in the following steps:

- Step 1: see section 4.4.
- Step 2: see section 4.4.
- Step 3: single-phase short-circuits are detected by the residual current devices since the neutral and exposed conductive part are earthed. These residual current devices are compulsory in a TT system. The type of short-circuit (non-visible to the residual current device), giving the lowest value, is the phase-to-phase fault; this is a phase-to-phase fault clear of earth.
- Step 4: the longest fault loop is the phase-to-phase short-circuit clear of earth at the point where the furthest away load is located (see Figure 4-23).



**Figure 4-23:** fault loop for a phase-to-phase short-circuit clear of earth in a TT system

$L$  is the longest circuit length from the circuit-breaker.

It can be seen that the fault flows through the two phases along length  $L$ .

The distance  $d$  of the circuit-breaker up to the circuit connection point is neglected.

– Step 5: the short-circuit current is calculated.

### **Impedance method**

We saw in section 4.2.3 that the current value of the phase-to-phase short-circuit clear of earth is:

$$I_{sc2} = \frac{\sqrt{3}V_n}{Z_{(1)} + Z_{(2)}}$$

$V_n$  : single-phase voltage

$Z_{(1)}$  : positive-sequence impedance

$Z_{(2)}$  : negative-sequence impedance

– if the network is not fed by a generator, then  $Z_{(1)} = Z_{(2)}$ .

– if the network is fed by a generator,  $Z_{(2)} < Z_{(1)}$ .

Taking  $Z_{(2)} = Z_{(1)}$ ,  $I_{scb}$  is minimized. With the aim being to calculate a minimum short-circuit current, this approximation can be used even when the network is fed by a generator.

Thus:

$$I_{scb} = \frac{\sqrt{3}V_n}{2Z_{(1)}}$$

$Z_{(1)}$  being the positive-sequence impedance of the supply source up to the fault point.

It is assumed that impedance  $Z_r$  of the network upstream of the switching device is known  $Z_r = R_r + jX_r$ .

Let:

$L$  : circuit length shown in Figure 4-23

$S_{ph}$  : cross-section of the circuit phase conductors

$\lambda$  : reactance per unit length of the conductors

$\rho$  : resistivity of the conductors equal to 1.5 times that at 20°C (which minimizes the short-circuit current)

The positive-sequence impedance  $Z_{(1)}$  is thus equal to:

$$Z_{(1)} = \sqrt{\left[ R_r + \frac{\rho L}{S_{ph}} \right]^2 + [X_r + \lambda L]^2}$$

The minimum short-circuit current is:

$$I_{sc2min} = \sqrt{3} \frac{V_n}{2Z_{(1)}}$$

$V_n$  single-phase no-load network voltage

### **Conventional method**

This method cannot be applied in installations fed by a generator.

The minimum short-circuit current is given in the formula:

$$I_{sc2min} = \frac{\sqrt{3} V_n \times 0.8}{2 \frac{\rho L}{S_{ph}}}$$

$V_n$  : single voltage in volts, during normal operation at the place where the switching device is installed

$L$  : length of the circuit shown in Figure 4-23

$\rho$  : resistivity of the conductors equal to 1.5 times that at 20°C (which minimizes the short-circuit current)

$S_{ph}$  : cross-section of the phase conductors

This method uses the following simplifications:

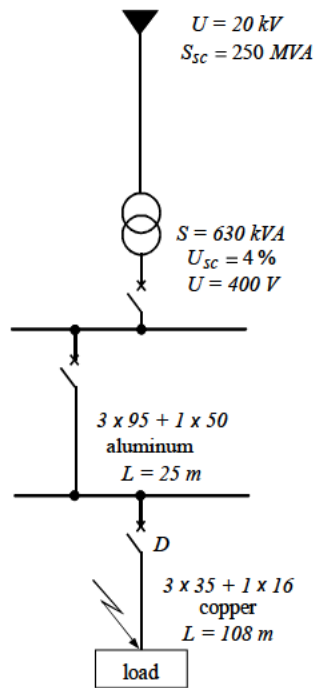
- It is assumed that in the event of a short-circuit, the voltage at the point where the protective device is located is equal to 80% of the rated voltage. In other words, it is assumed that the part of the fault loop upstream of the switching device represents 20% of the total impedance of the fault loop.

- The influence of the reactance of the conductors is negligible for cross-sections less than 150 mm<sup>2</sup>. The influence of conductor reactances is taken into account for large cross-sections by increasing the resistance by 15% for 150 mm<sup>2</sup> cross-sections, by 20% for 185 mm<sup>2</sup> cross-sections, by 25% for 240 mm<sup>2</sup> cross-sections and by 30% for 300 mm<sup>2</sup> cross-sections.

- The short-circuit is assumed to be solid, i.e. the arc resistances, contact and analogue resistances are not taken into account.

**Example**

Let us consider the diagram in Figure 4-24, corresponding to the configuration giving the smallest short-circuit current at the point where the load is located. We shall calculate the minimum short-circuit current at the location point of the load.



**Figure 4-24:** *TT system minimum short-circuit calculation example*

**Impedance method**

– upstream network

$$Z_A = \frac{U^2}{S_{sc}} = \frac{(400)^2}{250 \times 10^6} = 0.64 \text{ m}\Omega$$

Let us assume that:

$$\frac{R_A}{X_A} = 0.2, \quad R_A^2 + X_A^2 = 0.04 X_A^2 + X_A^2 = Z_A^2$$

$$X_A = \frac{Z_A}{\sqrt{1.04}} = 0.63 \text{ m}\Omega$$

$$R_A = 0.13 \text{ m}\Omega$$

– 630 kVA transformer,  $U_{sc} = 4\%$  according to Table 4-10

$$Z_T = 10.67 \text{ m}\Omega$$

$$X_T = 10.31 \text{ m}\Omega$$

$$R_T = 2.75 \text{ m}\Omega$$

– cable  $3 \times 95 \text{ mm}^2 + 1 \times 50 \text{ mm}^2$  Alu

$$R = \frac{0.043 \times 25}{95} = 11.32 \text{ m}\Omega$$

Let us assume that the cable is three-core,  $X_\ell = 0.08 \text{ m}\Omega/\text{m}$  (see section 4.2.1.4).

$$X = 0.08 \times 25 = 2 \text{ m}\Omega$$

The impedance of the network upstream of circuit-breaker CB can thus be determined:

$$R_r = 0.13 + 2.75 + 11.32 = 14.20 \text{ m}\Omega$$

$$X_r = 0.63 + 10.31 + 2 = 12.94 \text{ m}\Omega$$

For the cable downstream of circuit-breaker CB, in  $3 \times 35 \text{ mm}^2 + 1 \times 16 \text{ mm}^2$  copper:

$$\rho: 27 \text{ m}\Omega \text{ mm}^2/\text{m}$$

$$S_{ph}: 35 \text{ mm}^2$$

Let us assume that the cable is three-core  $X_\ell = 0.08 \text{ m}\Omega/\text{m}$ .

Then

$$Z_{(1)} = \sqrt{\left[14.20 + 27 \times \frac{108}{35}\right]^2 + [12.94 + 0.08 \times 108]^2}$$

$$Z_{(1)} = \sqrt{(97.5)^2 + (21.6)^2} = 99.9 \text{ m}\Omega$$

$$I_{sc2 \text{ min}} = \frac{230 \times \sqrt{3}}{2 \times 99.9 \times 10^{-3}} = 1,994 \text{ A}$$

### **Conventional method**

$$I_{sc2 \text{ min}} = \frac{\sqrt{3} \times V_n \times 0.8}{2\rho \frac{L}{S_{Ph}}} = \frac{\sqrt{3} \times 230 \times 0.8}{2 \times 0.027 \left(\frac{108}{35}\right)}$$

$$I_{sc2 \text{ min}} = 1,913 \text{ A}$$

We can see that in this example the conventional method minimizes the result of the minimum short-circuit current calculation by 4%.

#### *4.4.1.5. Influence of the minimum short-circuit current on the choice of circuit-breakers or fuses*

##### **Circuit-breaker protection**

Standard IEC 60364-4-43 (section 432) stipulates that the magnetic tripping threshold of the circuit-breaker must be lower than the minimum short-circuit current for TN and IT systems. For a given circuit length, and thus a stipulated minimum short-circuit current, a circuit-breaker with a suitable tripping threshold must be chosen. Or conversely, for a given circuit-breaker, a maximum circuit length respecting the magnetic tripping threshold can be used.

This condition is stipulated so that problems relating to the protection against indirect contact may be overcome.

##### **Example 1**

Let us take the example considered for the TN system in section 4.4.1.1 (see Figure 4-20).

A minimum short-circuit current value of 906 A was found using the impedance method and 850 A found using the conventional method.

The magnetic tripping threshold of circuit-breaker CB should therefore be lower than 906 A or 850 A depending on the method of calculation used.



In the same way, let us assume that the magnetic tripping threshold  $I_m$  of circuit-breaker CB is 600 A. We can calculate the authorized maximum length of the circuit protected by the circuit-breaker in a TN system:

– using the conventional method:

$$I_m = \frac{0.8 V_n}{\rho L_{\max} \left( \frac{1}{S_{ph}} + \frac{1}{S_N} \right)}$$

hence

$$L_{\max} = \frac{0.8 V_n}{I_m \rho \left( \frac{1}{S_{ph}} + \frac{1}{S_N} \right)} = \frac{0.8 \times 230}{600 \times 0.027 \left( \frac{1}{35} + \frac{1}{16} \right)} = 124.7 \text{ m}$$

– using the impedance method: the calculation is more complicated and difficult to do manually, and we shall not therefore produce it in detail, but it results in  $L_{\max} = 140.6 \text{ m}$ .

### Example 2

Let us take the example given for the IT system without distributed neutral in section 4.4.1.2 (see Figure 4-22).

A minimum short-circuit current value of 1,192 A was found using the impedance method and of 1,054 A using the conventional method.

The magnetic tripping threshold of circuit-breaker CB should therefore be lower than 1,192 A or 1,054 A depending on the method of calculation used.

In the same way, let us assume that the magnetic tripping threshold  $I_m$  of circuit-breaker CB is 600 A. We can therefore calculate the authorized maximum length of the circuit protected by the circuit-breaker in an IT system without distributed neutral:

– using the conventional method:

$$I_m = \frac{\sqrt{3} \times 0.8 V_n}{2 L_{\max} \rho \left( \frac{1}{S_{ph}} + \frac{1}{S_{PE}} \right)}$$

hence

$$L_{\max} = \frac{\sqrt{3} \times 0.8 V_n}{2 I_m \rho \left( \frac{1}{S_{ph}} + \frac{1}{S_{PE}} \right)} = \frac{\sqrt{3} \times 0.8 \times 230}{2 \times 600 \times 0.027 \left( \frac{1}{35} + \frac{1}{16} \right)} = 108 \text{ m}$$

– using the impedance method: the calculation is more complicated and difficult to do manually, and we shall not therefore produce it in detail, but it results in:  $L_{\max} = 128.5 \text{ m}$ .

Note 1: if we take the same example in an IT system *with distributed neutral*, and we assume that the cross-section of the neutral conductor is the same as that of the phase conductor, the following authorized maximum length of the circuit protected by circuit-breaker CB can be found:

– using the conventional method:

$$L_{\max} = \frac{108}{\sqrt{3}} = 62.3 \text{ m}$$

– using the impedance method:

$$L_{\max} = \frac{128.5}{\sqrt{3}} = 74.2 \text{ m}$$

Note 2: for a fixed circuit-breaker magnetic tripping threshold, we arrive at a higher authorized maximum length of the protected circuit in a TN system than in an IT system *without distributed neutral*, the maximum length of which is higher than in the IT system *with distributed neutral*.

### Fuse protection

Standard IEC 60364-4-41 (section 413.1.1.1) stipulates that the fault current should be cleared in a time compatible with the protection of persons for TN and IT systems.

This time is determined by a curve in relation to the presumed touch voltage which is based on the physiological effects of the electric current on the human body. To simplify matters, using this curve it is possible to determine an average switching time in relation to the nominal voltage of the installation (see Tables 4-20 and 4-21).

Nominal voltage $V_n/U_n$ (V)	Switching time (s) (1)	
	non-distributed neutral	distributed neutral
127/220	0.8	5
220/380, 230/400	0.4	0.8
400/690	0.2	0.4
580/1,000	0.1	0.2

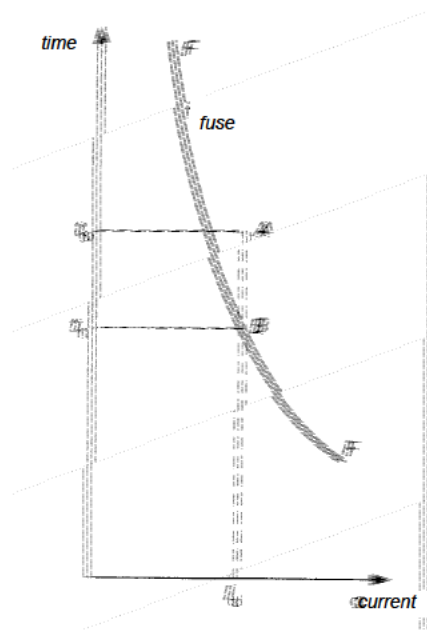
**Table 4-20:** maximum switching times in the IT system (double fault)  
(Table 41 B of IEC 60364-4-41)

Nominal voltage $V_n$ (Volts) (*)	Switching time (seconds) (1)
120-127	0.8
220-230	0.4
380-400	0.2
> 400	0.1
(*) These values are based on IEC 60038.	
(1) These values are not valid in premises containing a bath tub or shower.	

**Table 4-21:** maximum switching times in the TN system (Table 41A of IEC 60364-4-41)

The protection rule consists therefore in making sure that the fault current  $I_f$  causes the fuse to blow in less than the time stipulated in Tables 4-20 and 4-21.

In practice, for a given fuse blowing curve (see Figure 4-25):



$t_0$  : specified switching time to ensure protection of persons  
 $t_1$  : fuse blowing time for fault current  $I_f$

**Figure 4-25:** protection of persons using a fuse

If  $t_1$  is less than or equal to  $t_0$ , protection is ensured.

Note 1: if  $t_1$  is higher than  $t_0$ , but less than 5 seconds, protection is said to be ensured by IEC 60364-4-41, section 413.1.3.5 in the following cases:

- in distribution circuits when the protective conductor at the downstream end of the circuit is linked directly to the main equipotential bonding;
- in terminal circuits only supplying stationary equipment whose protective conductor is linked to the main equipotential bonding and which is located in the main equipotential bonding influence zone.

Note 2: in a TT system, protection of people is generally provided by residual current devices whose setting must satisfy the following condition (see IEC 60364-4-41, section 413.1.4.2):

$$R_A I_A \leq 50 V$$

$R_A$ : resistance of the earth of the exposed conductive parts

$I_A$ : rated residual current of the circuit-breaker

If selectivity is judged to be necessary, an operating time of the residual protection at the most equal to 1 second is admissible in distribution circuits.

Note 3: in an IT system, when the exposed conductive parts are earthed individually or in groups, the TT system conditions given in Note 2 must be respected (see IEC 60364-4-41, section 413.1.5.3).

#### **4.4.2. Calculating the minimum short-circuit current for medium and high voltages**

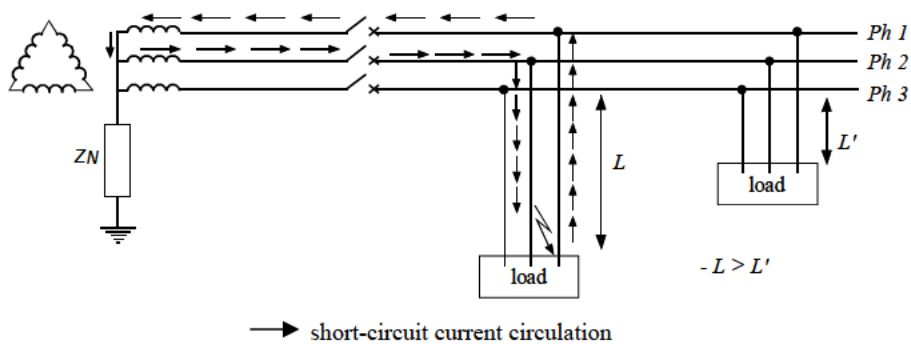
The method applied is the impedance method.

The procedure is carried out in the following steps:

- *Step 1*: determine the furthest point downstream of the switching device giving the lowest short-circuit current for which protection must be in place.
- *Step 2*: determine the upstream network configuration giving the minimum short-circuit current:
  - the lowest short-circuit current supply source which can be configured is determined. This is generally the standby generator if there is one;
  - the network configuration giving the longest link length up to the source is determined.

– *Step 3*: the type of short-circuit giving the lowest value is determined. For medium and high voltages, phase-to-earth short-circuits are cleared by the earth fault or directional earth fault protective devices. The neutral is not distributed, which implies that the short-circuit is minimum for a phase-to-phase fault clear of earth.

– *Step 4*: the length of the longest fault loop is determined, i.e. when a single phase-to-phase fault occurs at the point the furthest away in the protected zone, e.g. the furthest away load (see Figure 4-26).



**Figure 4-26:** fault loop for a phase-to-phase short-circuit clear of earth

$L$  is the longest length of the protected circuit from the circuit-breaker.

– *Step 5*: the short-circuit current is calculated.

We saw in section 4.2.3 that the phase-to-phase fault clear of earth is:

$$I_{sc2 \min} = \frac{\sqrt{3} V_n}{Z_{(1)} + Z_{(2)}}$$

$V_n$  : single-phase voltage

$Z_{(1)}$  : positive-sequence impedance

$Z_{(2)}$  : negative sequence impedance

$Z_{(1)}$  is the impedance equivalent to the positive-sequence impedance device through which the short-circuit current flows (length  $L$  and upstream network).

$Z_{(2)}$  is the impedance equivalent to the negative-sequence impedance device through which the short-circuit current flows (length  $L$  and upstream network).

Note 1: if the network cannot be fed by a generator:

$$Z_{(1)} = Z_{(2)} \quad I_{sc2min} = \frac{\sqrt{3}V_n}{2Z_{(1)}}.$$

Note 2: for the cable or line, the following always applies:  $Z_{(1)} = Z_{(2)}$  (see section 4.2.2.1).

Note 3: in the case where the network is fed by a generator, the minimum short-circuit current may be the three-phase short-circuit (see section 7.24).

***Using the minimum short-circuit current calculation for protection setting***

The minimum short-circuit current calculation allows the opening of switching devices to be ensured in the event of a phase-to-phase short-circuit in the protected zone:

- the phase overcurrent protection threshold (see section 7.1) must be such that  $I_r \leq 0.8 I_{sc2, \min}$ ;
- a fuse must be chosen such that its switching time for  $I_{sc2, \min}$  is lower than a specified value.

**4.4.3. Importance of the minimum short-circuit calculation for protection selectivity**

For amperemetric type selectivity, the minimum and maximum short-circuit currents at the location point of each switching device must be known (see section 9.1).

## Chapter 5

# Consequences of Short-circuits

### 5.1. Thermal effect

When a short-circuit occurs, a much larger current than the nominal current flows (10 to 100 times its value). This results in cables overheating which may damage the insulating material. The current must therefore be switched by a circuit-breaker or a fuse in a short enough time  $t_s$  for the cable temperature not to reach a critical value.

The thermal losses per unit of length is proportional to the square of the current:

$$P(t) = R_L I^2(t) \text{ in single-phase}$$

$R_L$  : resistance per unit length of the cable

If the current is not sinusoidal, the energy stored by the cable is:

$$E = R_L \int_0^{t_s} I^2(t) dt$$

$t_s$  : switching time of the switching device

If we take the approximate value of a short-circuit sinusoidal current  $I_{sc}$ , then:

$$E = R_L I_{sc}^2 t_s$$

$I_{sc}$  : r.m.s. value of the short-circuit current

In practice, the energy able to be stored in the cable depends on the conductor cross-section, the material of the core and the maximum temperature admissible in the insulating material.

A coefficient  $k$ , a function of the core material and the type of insulating material, is defined in LV (see Table 5-1) and can be applied in MV as follows:

$$k^2 S^2 \geq I_{sc}^2 t_s$$

hence:

$$S \geq \sqrt{t_s} \frac{I_{sc}}{k}$$

or where  $t_s \leq \frac{k^2 S^2}{I_{sc}^2}$

where:

$I_{sc}$  : short-circuit current at A

$t_s$  : switching time of the switching device in seconds

$S$  : conductor cross-section in mm<sup>2</sup>

Insulating material Conductor	PVC or PE	PR or EPR
Copper	115	135
Aluminum	74	87

**Table 5-1:** coefficient  $k$  value in compliance with IEC 60364-4-43

### Example 1

Let us take a 120 mm<sup>2</sup> PR-insulated copper cable protected by a circuit-breaker fitted with time-delayed magnetic trip relay which can be set at 0.1 second or 0.2 second. The short-circuit current at the terminals downstream of the circuit-breaker is 45 kA.

The maximum time for which the cable is able to withstand a short-circuit current is:

$$t_{\max} = \frac{k^2 A^2}{I_{sc}^2} = \frac{(135)^2 \times (120)^2}{(45,000)^2} = 0.130 \text{ s}$$

The circuit-breaker time delay must therefore be set at 0.1.

### Example 2

Let us take an installation with a short-circuit current of 55,000 A downstream of the supply transformer. We want to install a circuit-breaker with a magnetic trip relay set at 0.2 second (in compliance with load requirements, e.g. of a motor).



We want to install a PVC-insulated aluminum cable. The minimum cable cross-sectional area must be:

$$S_{\min} = \sqrt{t_s} \frac{I_{sc}}{k} = \frac{\sqrt{0.2 \times 55,000}}{74} = 332 \text{ mm}^2$$

A 400 mm<sup>2</sup> cross-section must therefore be used.

### 5.2. Electrodynamic effect

The maximum peak value of the current creates the maximum electrodynamic force observed in the network equipment.

This force, an electromagnetic effect, is referred to as the “Laplace force”.

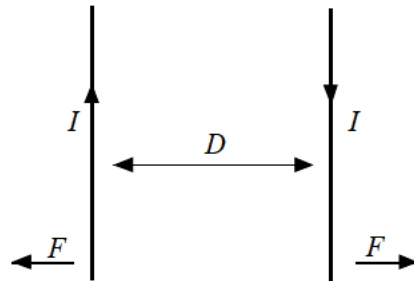
For example, the force per unit of length generated by two parallel conductors through which an identical current  $I$  flows is (see Figure 5-1):

$$F = 2 \times 10^{-8} \frac{I^2}{D} \text{ daN/m}$$

$F$  : in daN/m

$I$  : in amperes

$D$  : distance in meters between the two conductors



**Figure 5-1:** force per unit of length generated by two parallel conductors through which an identical current  $I$  flows

The forces are attractive if both currents flow in the same direction and repulsive if they do not.

In sinusoidal operating conditions, the equipment must be dimensioned in relation to the peak value of the short-circuit current. This is 1.6 to 2.5 times higher than the value of the steady-state short-circuit current (see section 4.1.1).

**Example**

Let us consider two bus sections of a low voltage switchboard, 10 cm apart, over a length of 30 cm and through which an identical short-circuit current  $I_{sc} = 100 \hat{kA}$  flows in the same direction.  $100 \hat{kA}$  is the peak value of the short-circuit current and corresponds, for example, to a steady-state short-circuit current of 50 kA for a coefficient  $K = 2$  (see section 4.1.1).

The maximum attractive force applied to each bus when a short-circuit occurs is:

$$F = 2 \times 10^{-8} \times \frac{(100,000)^2}{0.1} \times 0.3 = 600 \text{ daN}$$

If the bus sections are held by two supports, one on each side of the bus, the force applied to each support and to the bus connection system will be 300 daN.

This may possibly result in parts being deformed or broken.

**Effect on switching devices (circuit-breakers, switches or contactors)**

The separable contacts of the switching devices tend to open under the effect of this so-called repulsive electrodynamic force. This is why it is necessary to define the short-circuit making capacity of circuit-breakers or switches (see sections 8.1 and 8.2).

According to section 4.1.1, for an installation fed by a distribution network, the peak value of the short-circuit current is equal to  $K$  times the value of the steady-state short-circuit current where  $1.41 < K < 2.83$ .

The circuit-breaker or switch must be able to withstand this peak current, which occurs if the device is closed on a solid symmetrical three-phase short-circuit.

*Low voltage circuit-breakers*

In low voltage, standard IEC 60947-2, section 8.3.2.2.4 stipulates that equipment must have a ratio  $n$  between the short-circuit making capacity and the nominal short-circuit breaking capacity, in relation to the nominal short-circuit breaking

capacity for a  $\cos \varphi$  specified by the standard  $\left( \cos \varphi = \frac{R}{\sqrt{R^2 + X^2}} \right)$ : see Table 5-2.

nominal short-circuit breaking capacity $I_{sn}$ (A)	specified $\cos \varphi$	$n$
4,500 < $I_{sn} \leq$ 6,000	0.7	1.5
6,000 < $I_{sn} \leq$ 10,000	0.5	1.7
10,000 < $I_{sn} \leq$ 20,000	0.3	2
20,000 < $I_{sn} \leq$ 50,000	0.25	2.1
50,000 < $I_{sn}$	0.2	2.2

**Table 5-2:** ratio  $n$  between making capacity and breaking capacity (according to IEC 60947-2)

#### High voltage circuit-breakers

For high voltages, IEC 62271-100, section 4.103 stipulates a making capacity equal to at least 2.5 times the rated short-circuit breaking capacity; in a network where the coefficient  $K$  is greater than 2.5 (rare), a circuit-breaker with a breaking capacity greater than  $\frac{K}{2.5} \times I_{sc}$  (see section 8.2) must be installed.

$I_{sc}$  : maximum short-circuit current.

Note 1: the short-circuit making capacity is also referred to as the *electrodynamic withstand*.

Note 2: standard Schneider equipment complies with these standards, both in low voltage and high voltage. Any specific requirements must be checked for non-standard equipment or equipment *to be used in special conditions*.

### 5.3. Voltage drops

A fault in the installation or on the utility network results in a voltage drop in the network's healthy elements which is often less than the allowable load voltage.

This voltage drop may lead to difficulties which do not necessarily disappear when the fault is cleared.

### ***Effect on contactors***

For certain manufacturers, the coils designed to close the contacts of the circuit are directly fed by a voltage supply from the network; the contacts may open upon occurrence of the fault and may not close when normal operating conditions are restored.

### ***Effect on asynchronous motors***

The maximum torque of asynchronous motors is approximately proportional to the square of the supply voltage. A drop in voltage may therefore lead to the motor stopping if the fault lasts too long.

Furthermore, if several motors have greatly slowed down or stopped, once the voltage is restored, these motors create a high pick-up current (same principle as for start-up), and may trigger the protective devices or cause a drop in voltage themselves. It is sometimes necessary to provide a load shedding and reloading program after a fault has occurred to prevent high pick-up currents from being generated.

### ***Effect on generators***

When a serious fault in the utility network or internal network occurs, the active power exchanges are disturbed. This results in modification of the internal angles of the machines and risk of loss of synchronism with the utility network. Indeed, while the short-circuit lasts, the generator does not supply any active power but receives the power from the driving machine thus forcing the rotor to accelerate. A dynamic stability study of the behavior of generators upon occurrence of a fault may show the need to separate them from the network if the fault is not quickly cleared.

### ***Abnormal operation of power electronics***

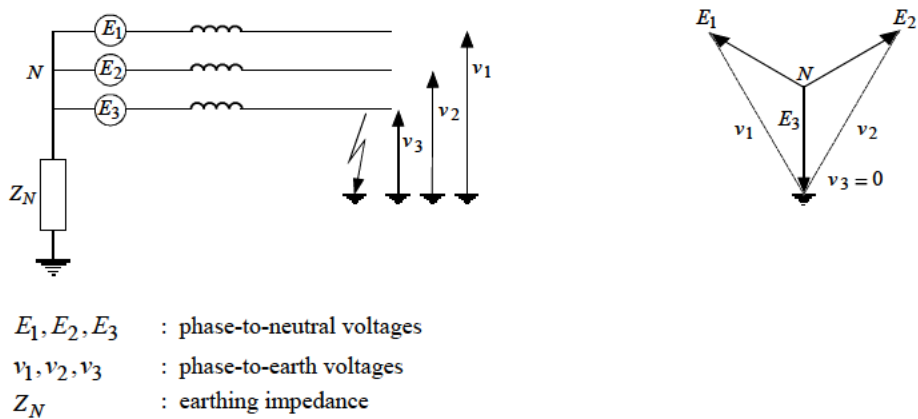
Rectifiers or inverters use thyristors which need a temporal reference allowing switching to take place at predetermined times. This temporal reference comes from the three-phase voltage system.

If the voltage almost reaches zero during a fault, the reference disappears which may lead to disturbances upon re-initialization of the process.

## **5.4. Transient overvoltages**

When a phase-to-earth fault occurs in an unearthed or limiting impedance earthed network (see section 2.2), the voltage between the healthy phases and earth becomes equal to the phase-to-phase voltage (see Figure 5-2). Consequently, so far

as earthing insulation is concerned, the network must be dimensioned for a phase-to-phase voltage and be able to withstand transient overvoltages so that a phase-to-phase fault is not generated. This problem is especially relevant in unearthed or Petersen coil earthed networks where, due to supply continuity requirements, phase-to-earth faults are detected but not immediately cleared (see section 2.2).



**Figure 5-2:** transient overvoltages in an unearthed or limiting impedance-earthed network when a phase-to-earth fault occurs

### 5.5. Touch voltages

When a fault occurs between a phase and an exposed conductive part or two phases and an exposed conductive part, a voltage coming from the current flowing in the earth conductor occurs between the exposed conductive part and earth or between two neighboring exposed conductive parts.

This voltage must not be dangerous. To make sure of this, the specifications provided in IEC 60364-5-54 concerning earthing of exposed conductive parts and of the neutral conductor should be followed. In particular, equipotential bonding must be installed between two simultaneously accessible exposed conductive parts.

### 5.6. Switching surges

The clearance of a fault means that a current in a generally inductive circuit is switched. This causes overvoltages referred to as “switching surges”, the maximum peak value of which is generally estimated to be two or three times the r.m.s. value of the nominal voltage (see section 10.1.1).

**5.7. Induced voltage in remote control circuits**

A high single-phase current in a power cable (a phase-to-earth fault, for example) induces a disturbing voltage on telecommunication lines located nearby.

Owing to their symmetry, three-phase short-circuits induce a zero sum of voltage, except when the layout of the remote control circuits is dissymmetrical in relation to the different phases; the induced voltage in this case is only rarely a problem.

**Calculating the induced voltage on a remote control circuit**

This is given in the following formula:

$$E_i = M \omega I L, \text{ Volts}$$

where  $\omega = 2\pi \times \text{frequency}$

$L$ : length of parallelism between the power cable and remote control cable in meters

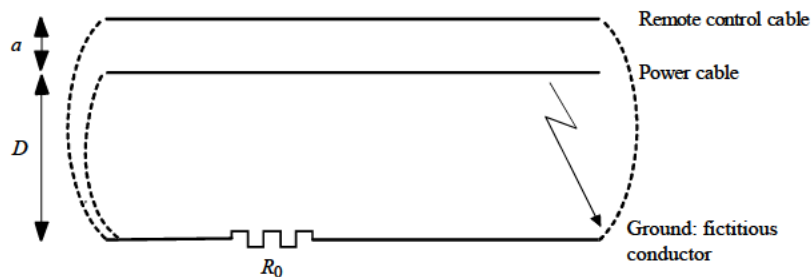
$I$ : short-circuit current value in the power cable at A

$M$ : mutual inductance between the two cables in H/m

**Calculating the mutual impedance  $M$  between the two cables**

This is made up of two current loops opposite each other, the power conductor and the ground, the telecommunication conductor and the ground (see Figure 5-3).

Earth may be considered to be a resistance conductor  $R_0$  located at a distance  $D$  from the surface of the ground.



$$R_0 = \frac{\omega \mu_0}{8} = 0.05 \Omega/km \text{ (for } f = 50 \text{ Hz)}$$

**Figure 5-3: mutual impedance between two cables**

For a ground resistivity of  $100\Omega\cdot m$  and a frequency of 50 Hz, then  $D = 935 \text{ m}$ .

The mutual impedance is determined using the following formula:

$$M = 0.1 \sqrt{\frac{\pi^2}{4} + \left(1 + 2Ln \frac{400}{x}\right)^2} \quad \mu H/m$$

where:

$$x = a \sqrt{\frac{f}{\rho}}$$

$a$ : distance in meters between the cables

$f$ : power cable current frequency

$\rho$ : electrical resistivity of the ground in  $\Omega \text{xm}$ . In the absence of precise information, a value  $\rho = 100 \Omega \text{xm}$  can be used as a first approximation for normal ground in a temperate area

Note: when an earth conductor accompanies the power cable, the fault current circulates in this conductor rather than earth. This results in a decrease in mutual impedance and thus a reduction in induced voltage. The value of the reduction factor is difficult to determine and it is therefore difficult to take it into account.

#### Example

Let us take the example of a power and remote control cable installed in the same trench, 30 cm apart, and in parallel over a length of 100 meters.

For a phase-to-earth short-circuit of 5,000 A, then:

$$x = a \sqrt{\frac{f}{\rho}} = 0.3 \sqrt{\frac{1}{2}} = \frac{0.3}{\sqrt{2}}$$

$$M = 0.1 \sqrt{\frac{\pi^2}{4} + \left(2Ln 400 \frac{\sqrt{2}}{0.3} + 1\right)^2} = 1.62 \mu H/m$$

$$E = 1.62 \times 10^{-6} \times 100 \times \pi \times 5,000 \times 100 = 253 V$$

Note: the CCITT (International Consultative Telegraph and Telephone Committee) specifies that the calculation is not required when all of the following conditions apply:

- nominal voltage of the power line  $\leq 20$  kV
- length of parallelism  $< 10$  km
- average gap between cables  $> 10$  m

Note: the presence on telecommunication lines of an earthed metal shield efficiently prevents induced voltages.

## Chapter 6

# Instrument Transformers

*Instrument transformer* is the standard term used for current and voltage transformers.

### 6.1. Current transformers

They provide a current proportional to the current flowing through the cable in order to perform energy metering or to analyze this current through a protection device.

#### 6.1.1. Theoretical reminder

Current transformers have similar compositions to “conventional” transformers. A magnetic circuit (generally made of an iron alloy) in the shape of a toroid is surrounded by  $n_1$  turns on the primary and  $n_2$  turns on the secondary (see Figure 6-1).

The primary can be reduced to a simple conductor passing through the toroid ( $n_1 = 1$ ) (see Figure 6-2).



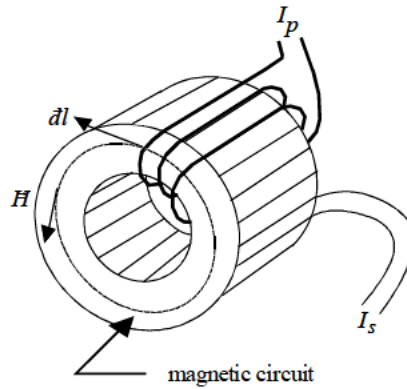


Figure 6-1:  $n_1 > 1$  wound primary type current transformer

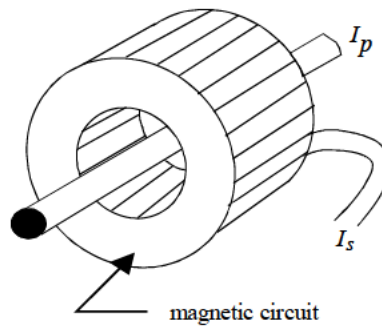


Figure 6-2:  $n_1 = 1$  ring type current transformer

Let  $I_p$  be the current flowing through the  $n_1$  primary turns and  $I_s$  be the current flowing through the  $n_2$  secondary turns.

According to Ampere's theorem, the sum of ampere-turns is equal to the circulation of the magnetic field vector  $\vec{H}$  :

$$n_1 I_p + n_2 I_s = \oint_{\text{torroid}} \vec{H} \cdot d\vec{l}$$

$d\vec{l}$  : vectorial element tangent to the circle generated by the torroid (see Figure 6-1)

The magnetic circuit channels the magnetic field, which is thus tangential to the circle created by the torroid, thus  $\vec{H}$  is parallel to  $d\vec{l}$  (see Figure 6-1).

Hence:

$$n_1 I_p + n_2 I_s = HL$$

where:

$$H = \frac{B}{\mu_o \mu_r}$$

$\mu_o$  : magnetic vacuum permeability

$\mu_r$  : relative permeability of the magnetic circuit (for iron  $\mu_r \approx 1,000$ )

$L$  : length of the torroid ( $2\pi$  x torroid radius)

$$n_1 I_p + n_2 I_s = \frac{B}{\mu_o \mu_r} L$$

The magnetic induction  $B$  is created by the windings and allows the transfer of energy from the primary to the secondary. We can see that when  $\mu_r$  is very high

(efficient magnetic core):  $\frac{B}{\mu_o \mu_r} L \rightarrow 0$  and  $I_s \approx -\frac{n_1}{n_2} I_p$ .

and we obtain the equation of the ideal transformer.

In the real transformer, we take  $\frac{B}{\mu_o \mu_r} L = n_2 I_m$

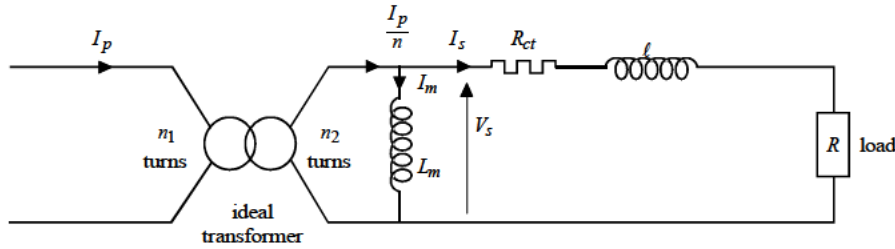
$I_m$  : magnetizing current

The introduction of  $I_m$  allows a mathematical model of the transformer to be established.

If we call  $n = \frac{n_2}{n_1}$  the transformation ratio, we obtain

$$\frac{I_p}{n} + I_s = I_m$$

The current transformer can thus be represented by the electrical diagram in Figure 6-3.



- $R_{ct}$  : represents the primary and secondary winding resistance
- $l$  : represents the magnetic circuit leakage inductances, generally  $l\omega \ll R_{ct}$
- $L_m$ : represents the magnetizing inductance which is very high since as we saw previously,  $I_m$  must be very low to come close to the ideal transformer ( $\mu_T$  very high)
- $R$  : represents the load and it will be assumed that it is perfectly resistive
- $V_s$  : secondary voltage of the current transformer

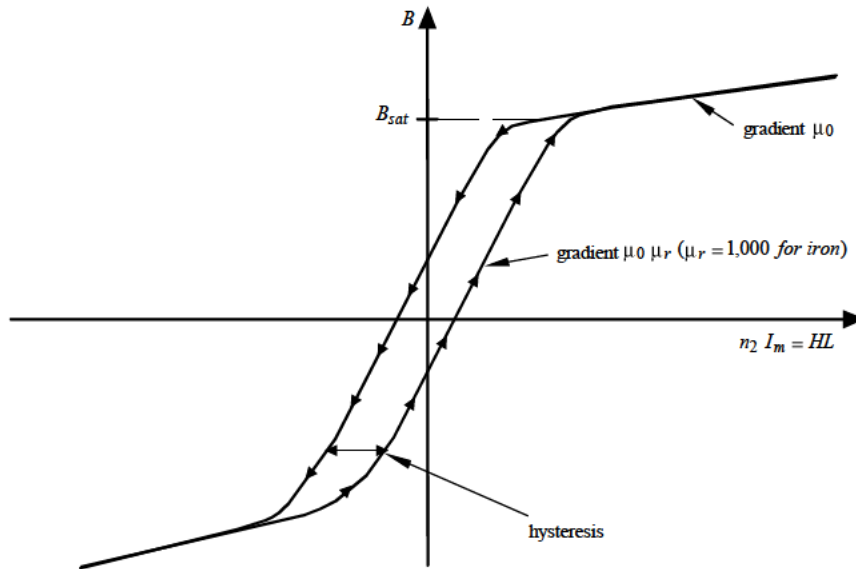
**Figure 6-3:** electrical diagram of the current transformer

The primary is a current source that is divided into a magnetizing current  $I_m$ , which is as small as possible as previously indicated, and a current  $I_s$  flowing through the load.

### 6.1.2. Saturation of the magnetic circuit

We previously saw that the quality of the CT was related to the relative permeability  $\mu_T$  of the magnetic circuit.

Now,  $\mu_T$ , which is approximately 1,000 for iron, becomes very small (several units) when  $B$  rises above the magnetic saturation induction  $B_{sat}$ . The magnetizing current or magnetic field  $H$  are related to induction  $B$  as in the curve in Figure 6-4.



**Figure 6-4:** magnetizing current curve in relation to magnetic induction  $B$

The law of induction provides us with the following relation:

$$V_s = -\frac{d\phi}{dt}$$

where  $\phi = n_2 BS$

hence:

$$V_s = -n_2 S \frac{dB}{dt}$$

$B$  : magnetic induction

$S$  : surface created by the turns ( $n_2$  = number of secondary turns)

$n_2$  : number of secondary turns

***B not saturated under normal operating conditions***

As we saw previously  $I_m$  is very low and if, to a first approximation,  $R_{ct}$  and  $\ell\omega$  are neglected in relation to  $R$ , then  $V_s = RI_s$  (see Figure 6-3).

hence:

$$\begin{aligned} R I_s(t) &= -n_2 S \frac{dB}{dt} \Rightarrow B(t) = -\frac{R}{n_2 S} \int I_s(t) dt \\ &\Rightarrow B(t) = -\frac{R n_1}{n_2^2 S} \int I_p(t) dt \\ &\text{as } I_s(t) = \frac{n_1}{n_2} I_p(t) \end{aligned}$$

$I_p(t)$  is a sinusoidal function of time.

Let us take  $I_p(t) = \hat{I}_p \sin(\omega t + \varphi)$  where  $\hat{I}_p$  = peak value of the primary current.

We obtain:

$$\begin{aligned} B(t) &= R \frac{n_1}{n_2^2 S \omega} \hat{I}_p \cos(\omega t + \varphi) \\ &= k R \hat{I}_p \cos(\omega t + \varphi) \end{aligned}$$

where  $k = \frac{n_1}{n_2^2 S \omega}$  is the constant characterizing the composition of the current transformer

$$= \hat{B} \cos(\omega t + \varphi)$$

where  $\hat{B} = k R \hat{I}_p$  is the peak induction value.

The induction  $B$  is thus a sinusoidal function of the time.

Because  $I_m$  is low in order to achieve an almost “ideal” transformer, the following must apply:  $\hat{B} < B_{sat}$  (see Figure 6-4), i.e.  $k R \hat{I}_p < B_{sat}$ .

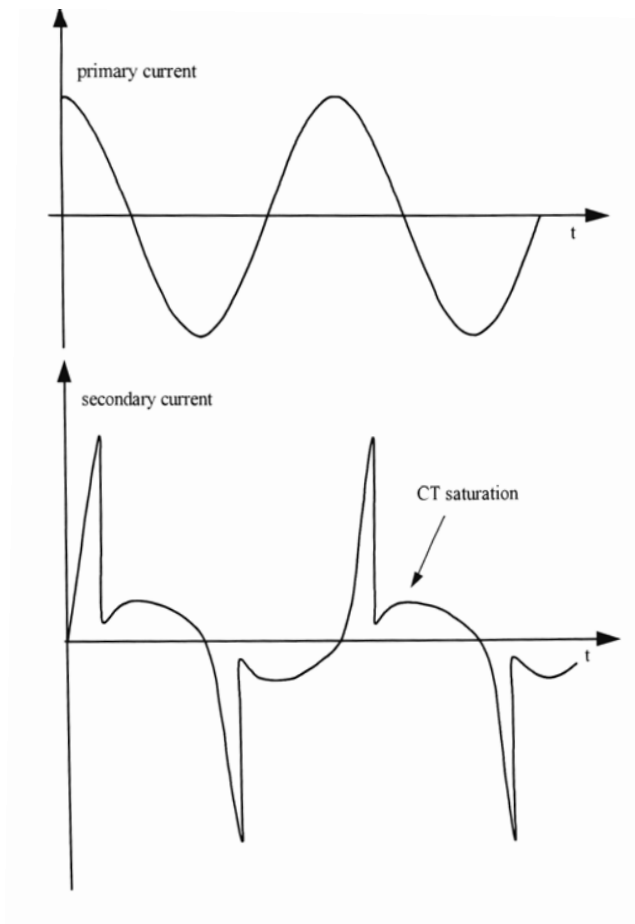
$B_{sat}$  : induction at saturation limit.

### **Saturation phenomenon**

When  $I_p$  is very large such that  $k R \hat{I}_p > B_{sat}$ , then  $\hat{B} > B_{sat}$ , the peak induction rises above the saturating limit induction, the exciting current  $I_m$  becomes very high (see Figure 6-4), the current transformer saturates and the equation  $\frac{I_p}{n} + I_s = I_m$  shows us that the current  $I_s$  drops when  $I_m$  increases.

A time curve in the form of peaks (see Figure 6-5) can thus be observed for  $I_s$ .

The peaks represent the period during which the current transformer is not saturated.



**Figure 6-5:** secondary current of a current transformer operating under saturated conditions

The r.m.s. value of the current  $I_s$  formed of peaks is calculated in Appendix C. In spite of the saturation, the r.m.s. value of the secondary current increases when the primary current increases. Overcurrent protection, measuring the r.m.s. value, will thus be activated even if the current transformer saturates.

On the other hand, for an accurate measurement of the current, saturation must be avoided. This requires that:

$$k R \hat{I}_p < B_{sat}$$

where  $k = \frac{n_1}{n_2^2 S \omega}$  and  $\hat{I}_p$  = peak value of the primary current.

#### **Maximum load at the CT terminals**

- The value  $B_{sat}$  is determined by the construction of the magnetic circuit.
- Let us take the nominal (primary) current  $I_{pn}$  for the CT.

This gives us the condition:

$$R < \frac{B_{sat}}{k \hat{I}_{pn}}$$

or

$$\hat{V}_s < \frac{B_{sat}}{kn}$$

since

$$R \hat{I}_{pn} = R n \hat{I}_s = n \hat{V}_s$$

It can thus be seen that for a CT with a nominal current  $I_{pn}$ , there is a maximum operating load that does not saturate the magnetic circuit and which produces an accurate measurement of the current. It can be observed that as a consequence, the CT has a maximum secondary voltage above which it becomes saturated.

This is why CT manufacturers, in compliance with IEC 60044-1, specify an accuracy power  $P$  in VA, which stipulates a maximum load by the relation  $Z_{max} I_n^2 = P$ . As for the British standard BS 3938, this gives a knee-point voltage  $V_K$  characterizing the limit voltage before saturation.

$Z_{max}$  is the maximum load of the CT. It includes the cable impedance linking the CT to the relay and the input impedance of the relay.

It is thus obvious that the distance between the CT and the relay must not be too great and that the connecting cable cross-section must sometimes be made bigger in order to reduce the total load impedance  $Z_l$ . This solution is generally less costly than increasing the accuracy power (IEC 60044-1) or the knee-point voltage (BS 3938).

### 6.1.3. Using CTs in electrical networks

#### 6.1.3.1. General application rule

Current transformers feed measuring, control and monitoring devices. Galvanic insulation electrically separates the primary circuit from the secondary circuit. It provides earthing of the electrical measuring device and thus ensures the safety of operating personnel.

The current transformer is designed to give the secondary a current that is proportional to the primary current. The secondary is connected to a low impedance (used in practically short-circuited conditions).

In a CT, the primary current/secondary current ratio is constant.

The secondary current is thus independent of the load as long as saturation is not reached (see section 6.1.2).

Let us consider the simplified electrical diagram of the current transformer (see Figure 6-6).

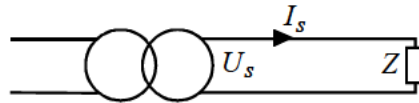


Figure 6-6: simplified electrical diagram of the current transformer

If  $Z$  is the secondary load impedance of the current transformer, then:

$$P = Z \times I_s^2$$

and

$$U_s = Z \times I_s$$

$P$  : power flowing to the secondary

$I_s$  : secondary current

$U_s$  : secondary voltage

If  $Z$  decreases, then  $P$  decreases.



If we short-circuit the secondary of a CT,  $Z = 0$ ,  $P = 0$ ,  $V_s = 0$  and there is no risk of destruction.

*We can short-circuit the secondary of a CT without any risk.*

On the other hand, if the secondary circuit remains open,  $Z$  tends towards infinity and the power and voltage would be theoretically infinite but are fortunately limited by the magnetic and copper losses of the CT.

Nevertheless, the voltage may reach peaks of several kV. It is therefore dangerous to leave a CT in an open circuit arrangement as this may generate overvoltages at its terminals which would be dangerous for both personnel and equipment under such conditions.

*Never leave the secondary circuit of a CT open.*

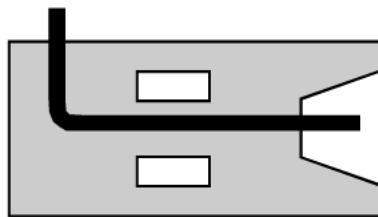
#### 6.1.3.2. Composition of a current transformer

The CT is made up of one or more primary windings around one or more secondary windings each having a magnetic circuit and the entire assembly being sealed in an insulating resin.

To guarantee a given level of accuracy, the product of  $N_1 \times I_p$  (number of primary turns x primary current) must always be above a certain value.

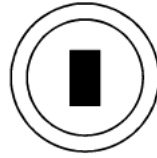
If  $N_1 = 1$ , then the device is:

– *bushing type*: the primary is reduced to a copper bar going through the secondary winding (see Figure 6-7). We find this type of CT in MV cubicles.



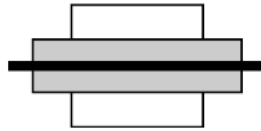
**Figure 6-7:** *bushing type transformer*

– *Bar primary type*: it is the compartment conductors of the MV cubicle that act as primary turns (see Figure 6-8).



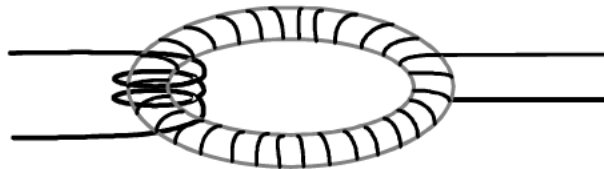
**Figure 6-8:** *bar primary type transformer*

– *Ring type*: this is a CT though LV-designed to be installed on a medium voltage cable or on a bushing (see Figure 6-9).



**Figure 6-9:** *ring type transformer*

If  $N_1 > 1$ , then the device is said to be of the wound type (see Figure 6-10).



**Figure 6-10:** *wound type current transformer*

#### 6.1.3.3. Specifications and definitions of current transformer parameters

The current transformer must meet requirements relating to protective, measuring and metering devices.

The specified use of the current transformer will help to determine the rated primary and secondary currents, the power and accuracy class.

The specifications of current transformers are only valid for normal conditions of use. A derating must be provided for in accordance with the ambient temperature and altitude.

*Rated primary current:* this is defined by the standard and it should be chosen from among the following values: 10 - 12.5 - 15 - 20 - 25 - 30 - 40 - 50 - 60 - 75 and their multiples or decimal factors.

*Rated secondary current:* this is equal to 1 A or 5 A.

*Transformation ratio ( $K_n$ ):* this is the ratio between the rated primary current and the rated secondary current.

*example: 100/5 A*

$$K_n = \frac{I_{pn}}{I_{sn}} = 20$$

*Accuracy power:* this is the apparent power (in VA at a specified power factor) that the transformer can supply to the secondary circuit for the rated secondary current and the accuracy load on which are based the accuracy conditions.

The standardized values are: 1 - 2.5 - 5 - 10 - 15 - 30 VA.

The accuracy power will be chosen according to the actual requirement. Overcalibrating an accuracy power is costly and may be dangerous for the measuring device as the saturation voltage is higher.

*Accuracy class:* this defines the guaranteed transformation ratio and phase displacement error limits under specific power and current conditions.

*Transformation ratio error:* this is the error as a percentage that the transformer introduces into the current measurement:

$$\text{current error (\%)} = \frac{(K_n I_s - I_p) \times 100}{I_p}$$

*Phase or phase displacement error:* this is the phase difference between the primary and secondary current. It is expressed in minutes.

*Rated thermal short-circuit current ( $I_{th}$ ):* this is the r.m.s. value of the primary current that the transformer can withstand for one second, its secondary being short-circuited.

To determine a thermal short-circuit current  $I'_{th}$  for a period  $T$  that is different from 1 second, the following formula may be used:

$$\left(I'_{th}\right)^2 \times T = \left(I_{th}\right)^2 \times 1$$

A time  $T = 3$  seconds is sometimes required by users and in this case it is difficult to obtain *wound* current transformers that withstand the short-circuit current for 3 seconds. It is thus preferable to use *bar primary* transformers

*Rated dynamic current* ( $I_{dyn}$ ): this is the peak value of the primary current (see section 4.1) that the transformer can withstand, its secondary being short-circuited. The normal value of the rated dynamic current is:  $I_{dyn} = 2.5 I_{th}$ .

#### 6.1.3.4. *Current transformers used for measuring in compliance with standard IEC 60044-1*

There are two requirements for measuring CTs. They must:

- have a level of accuracy suitable to the application for the normal operating current;
- protect the devices in the event of a fault current.

***The accuracy is defined by the accuracy class determining the permissible phase and current amplitude error over a range of 5% to 120% of the rated primary current***

The standardized IEC accuracy classes are: 0.1 - 0.2 - 0.5 - 1 - 3 - 5.

Classes 0.5 and 1 are used in the majority of cases.

Class 0.2 is only used for precision metering.

Classes 0.1 - 3 - 5 are never used in medium voltage.

*Specific case*: wide range current transformers are devices that can be used permanently with a primary current of 120, 150 or 200% of the rated current. The rise in temperature and transformer accuracy are guaranteed.

***Protection of metering devices in the event of a fault is defined by the safety factor SF***

This is the ratio between the rated primary limit current ( $I_{pl}$ ) and the rated primary current ( $I_{pn}$ ).  $I_{pl}$  is the value of the primary current for which the secondary current error is equal to 10% (see Figure 6-11).

The preferred SF values are 5 and 10.

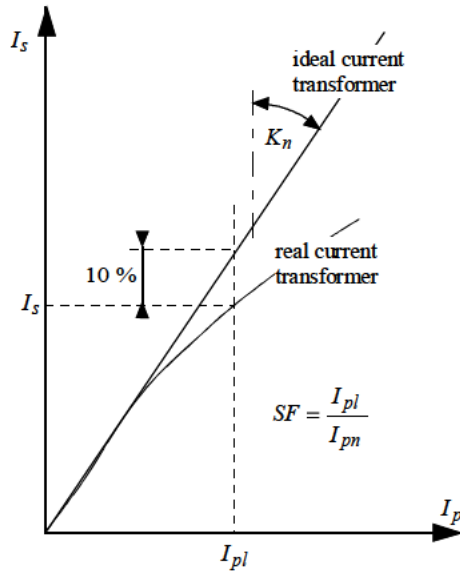


Figure 6-11: safety factor (SF) of measuring CTs

IEC 60044-1 gives the maximum current and phase displacement errors in relation to the accuracy class and rated primary current percentage (see Table 6-1).

Accuracy class	Rated primary current %	Current error ±%	Phase displacement error ± mn
0.2	5	0.75	30
	20	0.35	15
	100	0.2	10
	120	0.2	10
0.5	5	1.5	90
	20	0.75	45
	100	0.5	30
	120	0.5	30
1	5	3	180
	20	1.5	90
	100	1	60
	120	1	60
3	50	3	no limit
	120	3	no limit
5	50	5	no limit
	120	5	no limit

Table 6-1: maximum current and phase displacement errors in relation to the accuracy class for measuring CTs

**Example of a measuring current transformer**

500/1 A 15 VA cl 0.5

Rated primary current 500 A.

Rated secondary current 1 A.

Accuracy class: 0.5.

Accuracy power: 15 VA.

For a current between 100% and 120% of the nominal current, the current error is lower than  $\pm 0.5\%$  and the phase displacement error is lower than  $\pm 30$  mn.

For a current between 20% and 100% of the nominal current, the current error is lower than  $\pm 0.75\%$  and the phase displacement error is lower than  $\pm 45$  mn.

**6.1.3.5. Current transformers used for protection in compliance with standard IEC 60044-1**

There are two requirements for protective current transformers: they must have an accuracy limit factor and an accuracy class suitable to the application.

**Accuracy limit factor (ALF) suited to the application**

The accuracy limit factor is the ratio between:

- the accuracy limit current for which the error is guaranteed to be lower than 5 or 10% as long as the accuracy class is 5P or 10P (see Table 6-2);
- the rated primary current.

The larger the ALF the less likely the device is to become saturated:

$$ALF = \frac{I_{pl}}{I_{pn}}$$

The IEC ALF values are: 5 - 10 - 15 - 20 - 30.

Accuracy class	Composite error at accuracy limit current	Current error at $I_n$	Phase displacement error for rated current
5P	5%	$\pm 1\%$	$\pm 60$ mn
10P	10%	$\pm 3\%$	no limit

**Table 6-2:** maximum current and phase displacement errors in relation to the accuracy class for protective CTs

**Accuracy suited to the application**

Accuracy is defined by the accuracy class.

The IEC accuracy classes are 5P and 10P. The choice between one or the other will depend on the device connected; for an example, see Table 6-3.

Application	Accuracy class
high impedance differential protection (see section 7.6.1)	5P
phase overcurrent protection (see section 7.1)	10P

**Table 6-3:** example of accuracy class choices for protective CTs

**Example of a protective current transformer**

100/1 A 15 VA 5P10

Rated primary current ( $I_{pn}$ ): 100 A.

Rated secondary current ( $I_{sn}$ ): 1 A.

Accuracy power: 15 VA.

Accuracy class: 5P.

Accuracy limit factor (ALF): 10.

For a power supplied of 15 VA under 1 A, the maximum error on the secondary current will be:

- less than 1% at  $I_{pn} = 100$  A (see Table 6-2),  
thus  $(I_{sn} \times 1\%) = 1 \text{ A} \times 1\% = \pm 0.01 \text{ A}$  on the secondary;
- less than 5% at  $(I_{pn} \times \text{ALF}) = 100 \text{ A} \times 10 = 1,000 \text{ A}$  (see Table 6-2),  
thus  $(I_{sn} \times 10 \times 5\%) = 1 \text{ A} \times 10 \times 5\% = \pm 0.5 \text{ A}$  on the secondary.

The secondary current is thus between 9.5 and 10.5 A for a primary current of 1,000 A (i.e. 10 times  $I_{pn}$ ).

**6.1.3.6. Current transformers used for protection in compliance with BS 3938 (class X)**

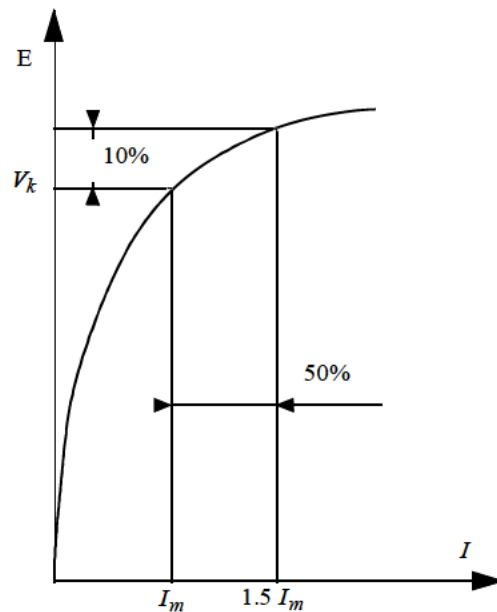
BS 3938 specifically defines current transformers designed for protection under the heading class X.

According to the British Standard, class X is defined by the rated secondary current, the minimum knee-point voltage, the maximum resistance of the secondary winding and the maximum magnetizing current at the rated knee-point voltage.

*Rated knee-point voltage ( $V_K$ ):* at the rated frequency this is the voltage value applied to the secondary terminals, which, when increased by 10%, causes a maximum increase of 50% in magnetizing current (see Figure 6-12).

*Maximum resistance of the secondary winding ( $R_{ct}$ ):* this is the maximum resistance of this winding, corrected at 75°C or at the maximum operating temperature if this is greater.

*Maximum magnetizing current ( $I_m$ ):* this is the value of the magnetizing current at the rated knee-point voltage, or at a specified percentage of this current (see Figure 6-12).

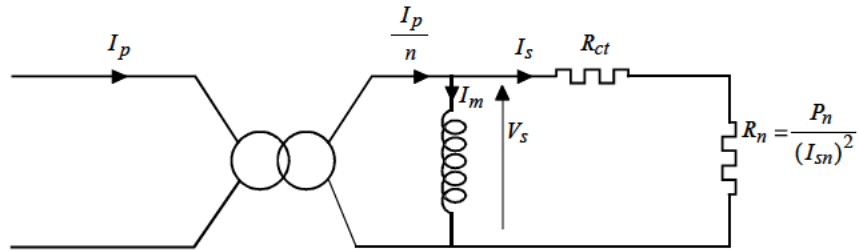


**Figure 6-12:** knee-point voltage and magnetizing current of a CT according to BS 3938 (class X)

#### 6.1.3.7. Correspondence between IEC 60044-1 and BS 3938 CT specifications

Consider the electrical diagram of the CT in Figure 6-13.





$R_{ct}$  : maximum resistance of the secondary winding

**Figure 6-13:** CT electrical diagram

Note: the leakage inductances  $\ell$  defined in the electrical diagram of Figure 6-3 are neglected since they are low compared with  $R_{ct}$ ,  $\ell \omega \ll R_{ct}$ .

**IEC 60044-1**

The standard defines a CT by its rated primary current  $I_{pn}$ , its rated secondary current  $I_{sn}$ , its accuracy power  $P_n$ , its accuracy class 5P or 10P, and its accuracy limit factor:  $I_{pn}/I_{sn} \quad P_n \quad 5P \quad K$  or  $I_{pn}/I_{sn} \quad P_n \quad 10P \quad K$ .

The CT accuracy power defines a nominal load  $R_n$  through the following relation:

$$R_n = \frac{P_n}{(I_{sn})^2}$$

It corresponds to a maximum load (connecting cable + protective relay input resistance) that the CT is able to withstand in order to continue to meet its operating limit requirements (for example, 5% error at  $20 I_{sn}$  for a 5P 20) (see section 6.1.2).

The resistance  $R_n$  is implicitly defined by IEC 60044-1.

The accuracy limit factors 5P and 10P respectively guarantee an error below 5% and 10% for a limit current  $I_s = K \times I_{sn}$ . This limit current in fact corresponds to the saturation knee-point of the CT which we saw in section 6.1.2, i.e. the secondary limit voltage generated by this current before saturation of the magnetic circuit.

If we call  $V_{S1}$  the limit voltage for a class 5P CT,

then:

$$V_{S1} = \left( R_{ct} + \frac{P_n}{(I_{sn})^2} \right) K I_{sn}$$

Similarly, if  $V_{S2}$  is the limit voltage of a class 10P CT, then:

$$V_{S2} = \left( R_{ct} + \frac{P_n}{(I_{sn})^2} \right) K I_{sn}$$

Note 1: voltage  $V_{S2}$  corresponds to a 10% “saturation” and voltage  $V_{S1}$  to a 5% saturation. Thus  $V_{S2} > V_{S1}$  for a given magnetic circuit.

Note 2: for a valid CT specification, it is important to know the value of  $R_{ct}$  given by the CT manufacturer. The value of  $R_{ct}$  is highly variable, from 0.02  $\Omega$  to 15  $\Omega$  depending on the CT specifications.

### **Standard BS 3938**

This defines the rated knee-point voltage  $V_K$ . This voltage, when applied to the terminals of the secondary increased by 10%, causes a maximum increase in magnetizing current of 50%.

The knee-point voltage  $V_K$  corresponds to the saturation of the magnetic circuit. Thus, similarly to the CTs defined by the IEC:

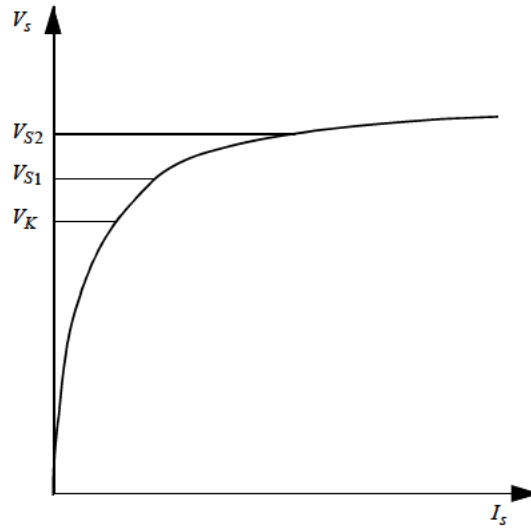
$$V_K = (R_{ct} + R) I_s$$

$R$  : load resistance

$I_s$  : secondary current

### **Correspondence between voltages $V_K$ and $V_{S1}$ or $V_{S2}$**

We can see that voltages  $V_K$  and  $V_{S1}$  or  $V_{S2}$  are of the same sort and correspond to a limit voltage before saturation of the magnetic circuit. These three voltages are different as the saturation knee-point has in fact an approximate value  $V_K \neq V_{S1} \neq V_{S2}$  (see Figure 6-14).



**Figure 6-14:** *correspondence between voltages  $V_K$  and  $V_{S1}$  or  $V_{S2}$*

In fact, these three voltages are defined differently: 5% error for class 5P, 10% error for class 10P and a 50% increase in magnetizing current for a voltage 10% higher than  $V_K$ .

Let us take the CTs manufactured by Schneider as an example. With the material used for the magnetic circuit of these CTs, tests show that:

- $V_{S1}$  corresponds to an induction of 1.6 teslas.
- $V_{S2}$  corresponds to an induction of 1.9 teslas.
- $V_K$  corresponds to an induction of 1.4 teslas.

Thus

$$\frac{V_{S1}}{V_{S2}} = \frac{1.6}{1.9} \quad \frac{V_K}{V_{S2}} = \frac{1.4}{1.9} \quad \text{and} \quad \frac{V_K}{V_{S1}} = \frac{1.4}{1.6}$$

#### 6.1.3.8. Use of CTs outside their nominal values

We have seen that a CT is limited by a maximum secondary voltage before saturation.

For standard IEC 60044-1:

$$V_{S1} = \left( R_{ct} + \frac{P_n}{(I_{sn})^2} \right) K I_{sn} \text{ for class 5P}$$

$$V_{S2} = \left( R_{ct} + \frac{P_n}{(I_{sn})^2} \right) K I_{sn} \text{ for class 10P}$$

where  $\frac{V_{S1}}{V_{S2}} = \frac{1.6}{1.9}$

For a given accuracy class, the stipulated condition of use is thus:

$$\left( R_{ct} + \frac{P_n}{(I_{sn})^2} \right) K I_{sn} = \text{constant}$$

$$(1) \quad \left( R_{ct} I_{sn} + \frac{P_n}{I_{sn}} \right) K = \text{constant}$$

$R_{ct}$ : is fixed by the construction of the CT

$I_{sn}$ : is the rated secondary current, which is also fixed by the construction of the CT, allowing the CT to operate without a rise in temperature

We thus have an infinity of pairs  $P_{ni}$ ,  $K_i$  enabling the operation of the CT to be defined. In practice, the number of pairs possible is limited by the nominal values to be used, as we shall see in the following examples.

Let us take the example of the following device: .../5 A 15 VA 5P 20.

The manufacturer has given us the value of  $R_{ct}$  (secondary winding resistance at 75°C).

$$\begin{aligned} R_{ct} &: & 0.2 \Omega \\ P_{n1} &: & 15 \text{ VA} \\ K_1 &: & 20 \end{aligned}$$

*Case 1*: we want to use it with an accuracy power of  $P_{n2} = 30 \text{ VA}$ . What is its accuracy limit factor  $K_2$ ?

According to the relation (1):

$$\left( R_{ct} I_{sn} + \frac{P_{n1}}{I_{sn}} \right) K_1 = \left( R_{ct} I_{sn} + \frac{P_{n2}}{I_{sn}} \right) K_2$$

$$\left( 0.2 \times 5 + \frac{15}{5} \right) 20 = \left( 0.2 \times 5 + \frac{30}{5} \right) K_2$$

$$K_2 = \frac{4 \times 20}{7} = 11.4$$

The standardized value to be used is that immediately less than  $K_2$ , i.e. 10.

We can therefore say that a 15 VA 5P 20 CT is suitable for a 30 VA 5P 10 use when  $R_{ct} = 0.2 \Omega$ .

*Case 2:* we want to use it with an accuracy limit factor  $K_2 = 10$ . What is its accuracy power?

According to the relation (1):

$$\left( R_{ct} I_{sn} + \frac{P_{n1}}{I_{sn}} \right) K_1 = \left( R_{ct} I_{sn} + \frac{P_{n2}}{I_{sn}} \right) K_2$$

$$\left( 0.2 \times 5 + \frac{15}{5} \right) 20 = \left( 0.2 \times 5 + \frac{P_{n2}}{5} \right) 10$$

$$4 \times 20 = 10 \left( 1 + \frac{P_{n2}}{5} \right)$$

$$P_{n2} = \left( \frac{80}{10} - 1 \right) \times 5 = 35 VA$$

The standardized value to be used is that immediately less than  $P_{n2}$ , i.e. 30 VA.

We can therefore say that 15 VA 5P 20 is suitable for a 30 VA 5P 10 requirement when  $R_{ct} = 0.2 \Omega$ .

*Case 3:* we want to use it with an accuracy class of 10P and an accuracy power of 30 VA. What is its accuracy limit factor?

We have seen that in class 10P the CT operates with a higher saturation level than in class 5P and

$$\frac{V_S(10P)}{V_S(5P)} = \frac{1.9}{1.6}$$

Thus:

$$\left( R_{ct} I_{sn} + \frac{P_{n2}}{I_{sn}} \right) K_2 = \frac{1.9}{1.6} \left( R_{ct} I_{sn} + \frac{P_{n1}}{I_{sn}} \right) K_1$$

$$\left( 1 + \frac{30}{5} \right) K_2 = \frac{1.9}{1.6} \left( 1 + \frac{15}{5} \right) 20$$

$$K_2 = 13.6$$

The standardized value to be used is that immediately less than  $K_2$ , i.e. 10. We can therefore say that a 15 VA 5P 20 CT is suitable for a 30 VA 10P 10 requirement.

*Case 4:* we want to use it with an accuracy class of 10P and an accuracy limit factor of  $K_2 = 10$ . What is its accuracy power?

We have seen that in class 10P the CT operates with a higher saturation level than in class 5P and

$$\frac{V_S(10P)}{V_S(5P)} = \frac{1.9}{1.6}$$

Thus:

$$\left( R_{ct} I_{sn} + \frac{P_{n2}}{I_{sn}} \right) K_2 = \frac{1.9}{1.6} \left( R_{ct} I_{sn} + \frac{P_{n1}}{I_{sn}} \right) K_1$$

$$\left(1 + \frac{P_{n2}}{5}\right)10 = \frac{1.9}{1.6} \left(1 + \frac{15}{5}\right)20$$

$$P_{n2} = \left(\frac{1.9}{1.6} \left(1 + \frac{15}{5}\right) \frac{20}{10} - 1\right)5$$

$$P_{n2} = 42.5$$

The standardized value to be used is that immediately less than  $P_{n2}$ , i.e. 30 VA. We can therefore say that a 15 VA 5P 20 CT is suitable for a 30 VA 10P 10 requirement.

*Case 5:* the application requirement is expressed in  $V_K$  knee-point voltage according to BS 3938. What is the knee-point voltage of the 15 VA 5P 20 CT?

We have seen that the knee-point voltage defined by standard BS 3938 is related to the maximum voltage  $V_S$  (5P) of a class 5P CT by the relation

$$\frac{V_S (5P)}{V_K} = \frac{1.6}{1.4} \text{ for Schneider Electric CTs.}$$

Thus:

$$\left(R_{ct} I_{sn} + \frac{P_n}{I_{sn}}\right)K = \frac{1.6}{1.4} V_K$$

$$\left(1 + \frac{15}{5}\right)20 = \frac{1.6}{1.4} V_K$$

$$V_K = 70 V$$

The knee-point voltage  $V_K$  defined by the British Standard is thus 70 V for a 15 VA 5P 20 CT where  $R_{ct} = 0.2 \Omega$ .

6.1.3.9. Example of a current transformer rating plate (see Figure 6-15)

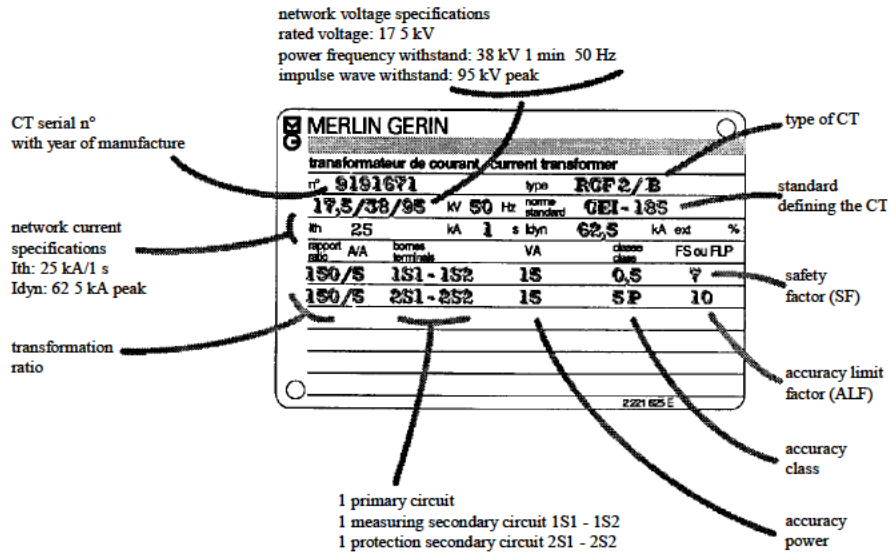
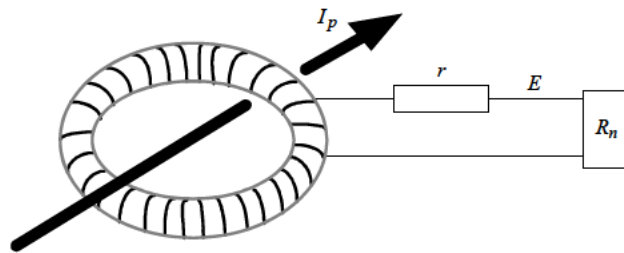


Figure 6-15: example of a current transformer rating plate

6.1.4. Non-magnetic current sensors

Non-magnetic current sensors emit an output signal in the form of a voltage proportional to the primary current derived (see Figure 6-16).



$r$  : adjustment resistance  
 $E$  : output voltage

Figure 6-16: non-magnetic current sensor



Non-magnetic current sensors used by Schneider Electric operate according to the Rogowski principle and supply their secondary with a voltage that is proportional to the primary current derived.

In the absence of a magnetic core, the coil winding technique gives the sensor the following properties:

- absence of saturation, hysteresis and remnant flux;
- perfect response in transient state operating conditions;
- ideal linearity.

All phenomena are faithfully reproduced.

Non-magnetic current sensors are designed to form a coherent protection and measuring unit with the Sepam relay of Schneider. At present they cannot be used for rate metering.

## 6.2. Voltage transformers

The electrical operation theory of voltage transformers is analogous to that of power transformers. We shall not cover it in this discussion.

### 6.2.1. General application rule

The voltage transformer is a transformer connected to a very high impedance (used on an almost open circuit).

A voltage transformer is designed to give the secondary a voltage proportional to that applied to the primary. For a VT, the primary voltage/secondary voltage ratio is constant. The secondary voltage is independent of the load.

Let us consider the simplified electrical diagram of the voltage transformer (see Figure 6-17).

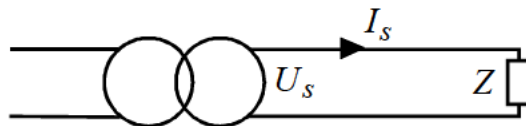


Figure 6-17: simplified electrical diagram of the voltage transformer

If  $Z$  is the secondary load impedance of the VT (voltage transformer), then:

$$P = \frac{U_s^2}{Z} \text{ and } I_s = \frac{U_s}{Z}$$

$P$  : power flowing to the secondary

$I_s$  : secondary current

$U_s$  : secondary voltage (imposed by the primary circuit)

If  $Z$  increases, then  $P$  and  $I_s$  decrease.

At the terminals of a VT, it is thus possible to install an impedance with a value ranging between the VT's nominal impedance and infinity without any risk.

*A VT can thus be left in an open circuit arrangement without any risk.*

On the other hand, if  $Z$  is reduced, the current supplied is too high and the VT will deteriorate.

*Never short-circuit a VT.*

IEC 60044-2 defines the requirements which voltage transformers must meet.

The VT comprises a primary winding, a magnetic circuit, one or more secondary windings, the whole assembly being sealed in an insulating resin.

### **6.2.2. Specifications and definitions of voltage transformer parameters**

The voltage transformer must comply with the network specifications.

As with any device, the voltage transformer must meet requirements relating to the voltage, current and frequency.

Voltage transformer specifications are only valid for normal conditions of use. A derating should be provided for in accordance with the ambient temperature and the altitude.

*Rated voltage factor:* this is the factor by which the rated primary voltage must be multiplied in order to determine the maximum voltage for which the transformer must attain the required levels of heating and accuracy.

The voltage factor is determined by the maximum operating voltage, which depends on the network earthing system and the way the VT's primary winding is

connected. The voltage transformer must be able to withstand this maximum voltage for the time necessary to clear the fault (see Table 6-4).

Rated voltage factor	Rated time	Primary winding connection method	Network earthing system
1.2	continuous	phase to phase	any
1.2	continuous	between the neutral point of a star transformer and earth	any
1.2	continuous	phase to earth	directly earthed neutral
1.5	30 seconds		
1.2	Continuous	phase to earth	limiting resistance earthing with automatic earth fault clearance (tripping upon first fault)
1.9	30 seconds		
1.2	continuous	phase to earth	earthed neutral without automatic earth fault clearance (no tripping upon first fault)
1.9	8 hours		
1.2	continuous	phase to earth	tuned limiting reactance (or Petersen coil) earthing without automatic earth fault clearance (no tripping upon first fault)
1.9	8 hours		

Note: smaller time ratings are permissible by agreement between manufacturer and user.

**Table 6-4:** normal values of the rated voltage factor

*Rated primary voltage (Up):* depending on their design, voltage transformers will be connected either:

- between phase and earth (see Figure 6-18(a)); or
- between phases (see Figure 6-18(b)).

$$\frac{3,000}{\sqrt{3}} / \frac{100}{\sqrt{3}} \quad U_p = \frac{U}{\sqrt{3}} \quad 3,000 / 100 \quad U_p = U$$

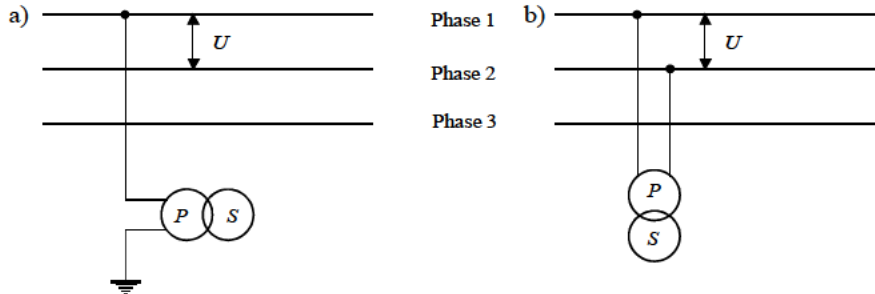


Figure 6-18: voltage transformer connection

The voltage transformer must be suited to requirements relating to protection and measuring devices.

The foreseen application of the voltage transformer is used to determine the rated secondary voltage, the accuracy power, the accuracy class and the thermal power limit.

*Rated secondary voltage:* this is equal to 100 or 110 V for phase/phase VTs. For single-phase transformers designed to be connected between a phase and earth, the rated secondary voltage is divided by  $\sqrt{3}$ .

*For example:*

$$\frac{100}{\sqrt{3}}$$

*Accuracy power:* this is expressed in VA and it is the apparent power that the voltage transformer can supply to the secondary when it is connected under its rated primary voltage and connected to its accuracy load. It must not introduce an error in excess of the values guaranteed by the accuracy class.

The standardized values are:

10 - 15 - 25 - 30 - 50 - 75 - 100 - 150 - 200 - 300 - 400 - 500 - VA.

*Accuracy class:* this defines the guaranteed transformation ratio and phase error limits in specified power and voltage conditions.

*Voltage ratio error:* this is the error that the transformer introduces in the voltage measurement:

$$\text{voltage error (\%)} = \frac{(K_n U_s - U_p) \times 100}{U_p}$$

*Phase or phase displacement error:* this is the phase difference between the primary and secondary voltages and is expressed in minutes.

*Rated thermal limiting output:* this is the apparent power that the transformer can permanently supply at its rated secondary voltage without exceeding the heating limits stipulated in the standards.

### 6.2.3. Voltage transformers used for measuring in compliance with IEC 60044-2

Table 6-5 gives the accuracy class generally used in accordance with the corresponding application.

Application	Accuracy class
not used in industry	0.1
precision metering	0.2
usual metering	0.5
statistical metering and/or measurement	1
measurement not requiring high accuracy	3

**Table 6-5:** accuracy class in accordance with the application for measuring VTs

The accuracy class is guaranteed if the voltage is between 80 and 120% of the rated primary voltage and for any load between 25 and 100% of the rated accuracy power with an inductive power factor of 0.8.

- The standardized IEC accuracy classes are: 0.1 - 0.2 - 0.5 - 1 - 3.
- Classes 0.1 and 0.2 are only used for laboratory devices.
  - Classes 0.5 and 1 are used in the majority of cases.
  - Class 3 is used very little.

IEC 60044-2 gives the maximum voltage and phase displacement errors in accordance with the corresponding accuracy class (see Table 6-6).

Accuracy class	Voltage error (of ratio) in ±%	Phase displacement ± minutes	Phase displacement ± centiradians
0.1	0.1	5	0.15
0.2	0.2	10	0.3
0.5	0.5	20	0.6
1.0	1.0	40	1.2
3.0	3.0	not specified	not specified

**Table 6-6:** maximum voltage and phase displacement errors in accordance with the accuracy class for measuring VTs

**Example of a measuring voltage transformer**

$$\frac{20,000}{\sqrt{3}} / \frac{110}{\sqrt{3}} \quad 100 \text{ VA cl1}$$

$$\text{Primary voltage} = 20,000 \text{ V} / \sqrt{3}$$

$$\text{Secondary voltage} = 110 \text{ V} / \sqrt{3}$$

$$\text{Accuracy power} = 100 \text{ VA}$$

$$\text{Accuracy class} = 1$$

This means that for a load between  $100/4 = 25 \text{ VA}$  and  $100 \text{ VA}$ , and a primary voltage between:

$$20,000 \times \frac{80}{100} = 16,000 \text{ V} \quad \text{and} \quad 20,000 \times \frac{120}{100} = 24,000 \text{ V}$$

The voltage error will be more or less 1% and the phase displacement error will not exceed 40 minutes.

**6.2.4. Voltage transformers used for protection in compliance with IEC 60044-2**

The IEC accuracy classes are 3P and 6P. In practice, only class 3P is used.

The accuracy class is guaranteed for the following values:

– voltages between 5% of the primary voltage and the maximum value of this voltage which is the product of the primary voltage and the rated voltage factor ( $kT \times U_n$ ) (see Table 6-7);

– for a secondary load between 25% and 100% of the accuracy power with an inductive power factor of 0.8.

Accuracy class	Voltage error in $\pm\%$		Phase displacement in minutes	
	between 5% of $U_n$ and $kT \times U_n$	between 2% and 5% of $U_n$	between 5% of $U_n$ and $kT \times U_n$	between 2% and 5% of $U_n$
3P	3	6	120	240
6P	6	12	240	480

$U_n$  : rated voltage

$kT$  : voltage factor

**Table 6-7:** maximum voltage and phase displacement errors in accordance with the accuracy class for protective VTs

**Example of a protective voltage transformer**

$$\frac{20,000}{\sqrt{3}} / \frac{110}{\sqrt{3}} \quad 100 \text{ VA} \quad \text{cl3P}$$

$kT = 1.9$

rated duration = 8 hours

The maximum voltage error will be 3% and the maximum phase displacement will last 120 minutes for a load between  $25\% \times 100 = 25 \text{ VA}$  and  $100 \text{ VA}$  with an inductive power factor of 0.8.

The maximum voltage that the VT can withstand is:

$$1.9 \times \frac{20,000}{\sqrt{3}} = 21.9 \text{ kV} \quad \text{for 8 hours}$$

Note: for earth faults, an assembly of three single-phase voltage transformers is used to make up an open delta so that the residual voltage can be measured (see Figure 7-15). In this case, the nominal secondary voltages generally used are:

$$\frac{100}{3} \text{ V} \quad \text{and} \quad \frac{110}{3} \text{ V}$$

6.2.5. Example of the rating plate of a voltage transformer used for measurement (see Figure 6-19)

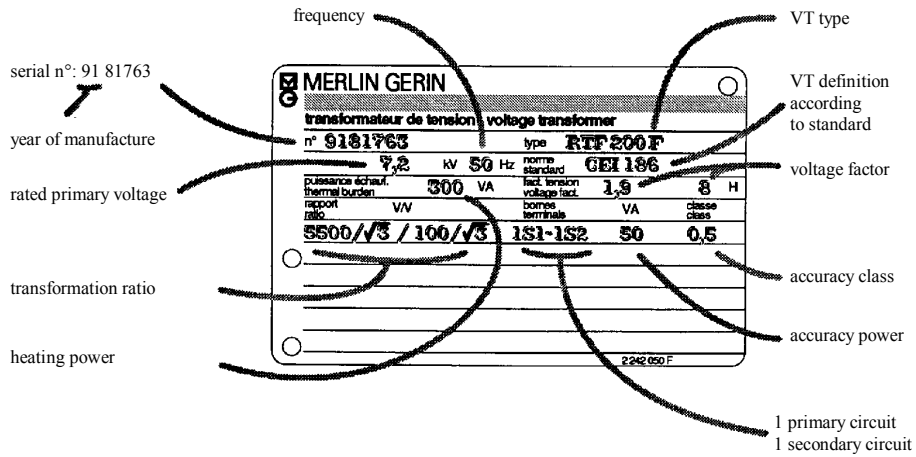


Figure 6-19: example of the rating plate of a measuring voltage transformer



## Chapter 7

# Protection Functions and their Applications

Protection functions are provided by relays or multifunctional devices like the Schneider Sepam.

Protective relays (or multifunctional devices) are devices that permanently compare the electrical variables of networks (such as current, voltage, frequency, power, and impedances) with predetermined values, and then automatically emit orders for action (usually the opening of a circuit-breaker) or give off an alarm when the monitored value goes above the threshold.

The role of protective relays is to detect any kind of abnormal phenomena that may arise in an electrical circuit, such as short-circuits, variation in voltage, machine faults, etc.

The relay may be:

- without auxiliary power (autonomous) when the energy required for it to operate is supplied directly by the monitored circuit (see Figure 7-1). The actuator must be sensitive because the energy supplied by the circuit is limited;
- with auxiliary power supply when the energy required for it to operate is supplied by an auxiliary voltage source (AC or DC) independent of the circuit monitored (see Figure 7-2).

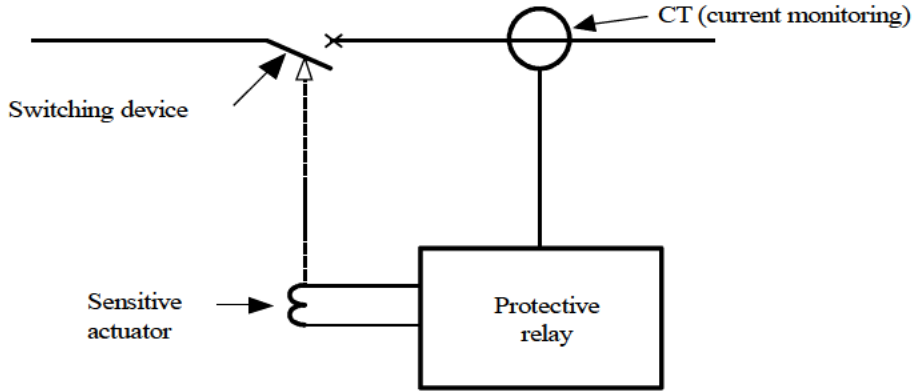


Figure 7-1: connection of an overcurrent relay without auxiliary power

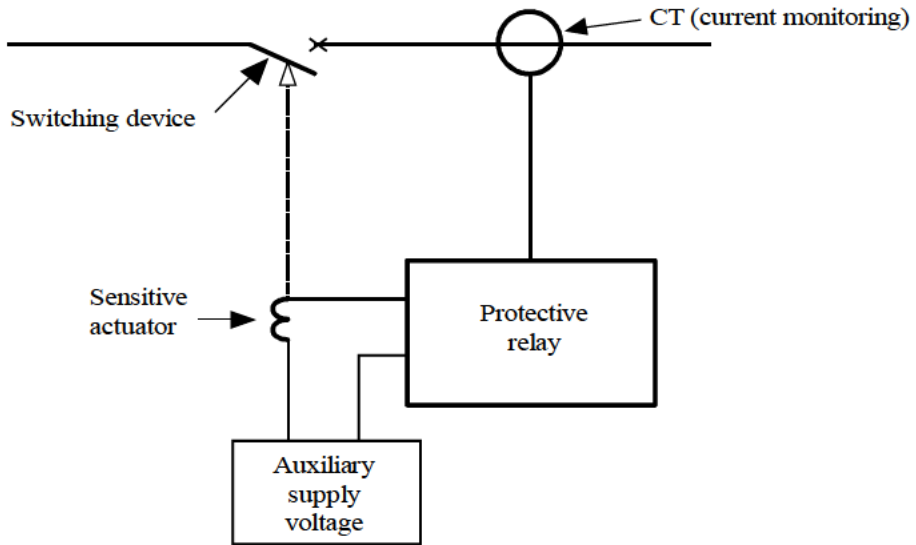


Figure 7-2: connection of an overcurrent relay with auxiliary power

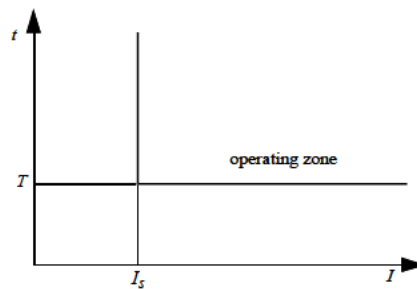
### 7.1. Phase overcurrent protection (ANSI code 50 or 51)

The function of this protection is to detect single-phase, two-phase or three-phase overcurrents.

Protection is activated when one, two or three of the currents concerned rise above the specified setting threshold.

This protection can be time delayed and in this case will only be activated if the current monitored rises above the setting threshold for a period of time at least equal to the time delay selected. This delay can be an independent (definite) time or inverse time delay.

**Independent time protection (see Figure 7-3)**



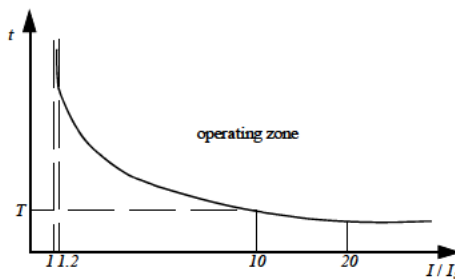
$I_{set}$  : operating current threshold  
 $T$  : protection operation time delay

**Figure 7-3: independent time delay**

The current threshold and the time delay are generally set by the user.

**Inverse time protection**

The time delay depends on the ratio between the current measured and the operating threshold. The higher the current means the shorter the time delay (see Figure 7-4).



$I_{set}$  : operating current threshold corresponding to the vertical asymptote of the curve  
 $T$  : operating delay for 10  $I_{set}$

**Figure 7-4: inverse time protection**

Inverse time protection operation is defined by standards IEC 60255-3 and BS 142. These standards define several types of inverse time protection that are distinguished by the gradient of their curves: standard inverse, very inverse or extremely inverse time protection. For example, the Schneider Sepam 2000 proposes the curves in Figure 7-5 set for a time delay of 1 second (implies an operating delay of 1 second for  $I = 10 I_{set}$ ).

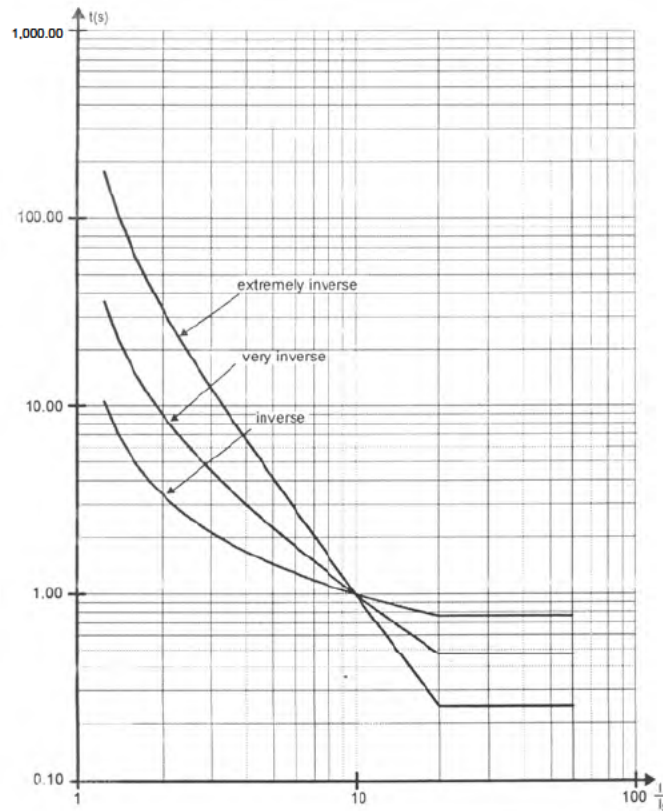


Figure 7-5: standard inverse, very inverse and extremely inverse curves at  $T = 1$  second

## 7.2. Earth fault protection (ANSI code 50N or 51N, 50G or 51G)

This function is used to protect the network against earth faults.

The protection is activated if the residual current  $I_{rsd} = I_1 + I_2 + I_3$  rises above the setting threshold. The residual current corresponds to the current flowing through earth (see section 4.3.5). The protection operates in a similar way to the phase overcurrent protection as far as the curves are concerned  $t = f(I_{rsd})$  (see Figures 7-3, 7-4 and 7-5).

The protection is set so that it is as sensitive as possible in order to detect low earth fault currents.

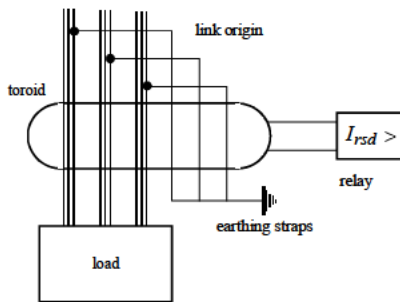
**Residual current measurement**

The residual current characterizing the earth fault current is obtained in one of the following two ways:

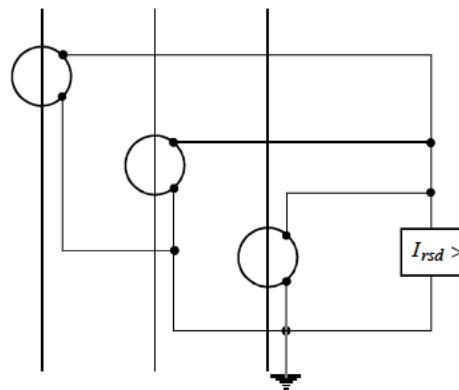
- by a core balance transformer through which the three phase conductors pass. The toroid turns encircle a magnetic flux  $\phi_{rsd}$  such that  $\phi_{rsd} = \phi_1 + \phi_2 + \phi_3$  (see Figure 7-6).  $\phi_1, \phi_2$  and  $\phi_3$  are proportional to the phase currents  $I_1, I_2$  and  $I_3$ , and  $\phi_{rsd}$  is thus proportional to the residual current.

The earthing strap shown in Figure 7-6 must go through the toroid so that an internal cable fault (core-shield) can be detected. Indeed, in the opposite case, the short-circuit current circulates in the cable core and comes back via the shield. It is therefore not detected by the toroid;

- by three current transformers whose neutrals are connected, thus making the sum  $I_{rsd} = I_1 + I_2 + I_3$ , which is the system generally used in MV and HV (see Figure 7-7).



**Figure 7-6:** residual current measuring instrument using a core balance



**Figure 7-7:** residual current measuring instrument using three current transformers

**Minimum threshold setting of earth protection**

There is a risk of spurious tripping of the protection due to measurement error of the residual current, specifically in the presence of transient currents. In order to prevent this risk, protection setting must be above:

- approximately 12% of the nominal rating of the CTs when measurement is carried out using three current transformers;

– 1 A for a time delay of 0.1 second when measurement is carried out using a core balance.

*Making protection insensitive to third and multiples of third harmonics*

Protection must be made insensitive to third and multiples of third harmonics that may come from the network or from the saturation of the CTs during high pick-up currents or transient operating conditions including aperiodic components.

Indeed, third and multiples of third harmonics are detected by the protection as a residual current because they are in phase.

Let us take three balanced currents  $i_1$ ,  $i_2$  and  $i_3$  with a phase displacement of  $1/3$  of a period:

$$\begin{aligned}i_1(t) &= \hat{I} \cos \omega t \\i_2(t) &= \hat{I} \cos \omega \left( t + \frac{T}{3} \right) \\i_3(t) &= \hat{I} \cos \omega \left( t + \frac{2T}{3} \right)\end{aligned}$$

where  $T = \frac{2\pi}{\omega}$  signal period

Note: the phase displacement of the currents is temporal and must therefore be written as shown above.

By replacing  $\omega$  by  $3\omega$ , the third harmonics of these three currents are:

$$\begin{aligned}i_{1h3}(t) &= \hat{I}_{h3} \cos 3\omega t \\i_{2h3}(t) &= \hat{I}_{h3} \cos 3\omega \left( t + \frac{T}{3} \right) = \hat{I}_{h3} \cos (3\omega t + \omega T) = \hat{I}_{h3} \cos (3\omega t + 2\pi) = \hat{I}_{h3} \cos 3\omega t \\i_{3h3}(t) &= \hat{I}_{h3} \cos 3\omega \left( t + \frac{2T}{3} \right) = \hat{I}_{h3} \cos (3\omega t + 2\omega T) = \hat{I}_{h3} \cos (3\omega t + 4\pi) = \hat{I}_{h3} \cos 3\omega t\end{aligned}$$

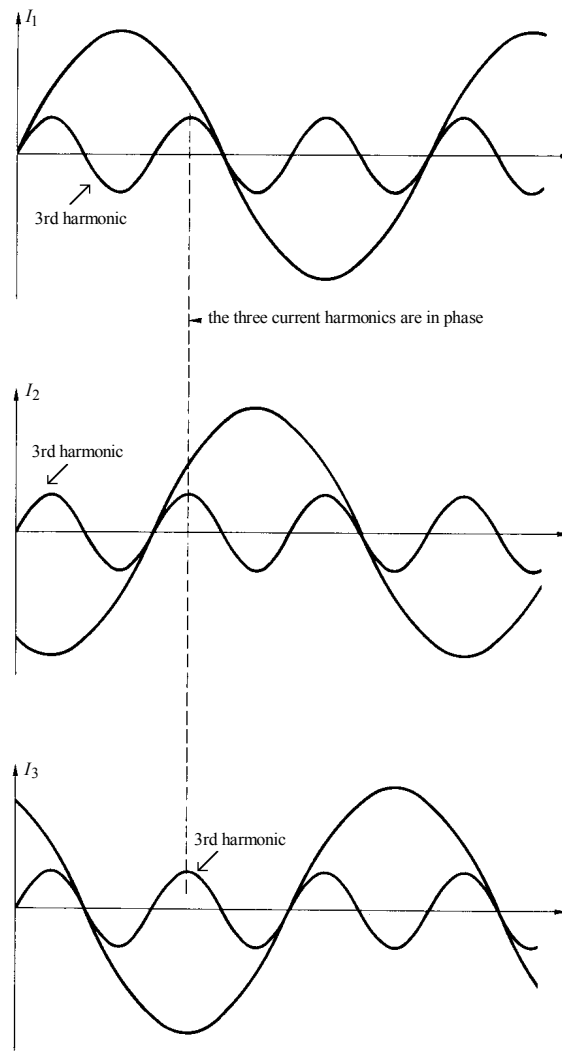
thus:

$$I_{1h3}(t) + I_{2h3}(t) + I_{3h3}(t) = 3 \hat{I}_{h3} \cos 3\omega t$$

We can also see graphically that the third harmonics are in phase (see Figure 7-8). The same applies for all multiples of the third harmonics.

In the absence of an earth fault, the residual current is equal to three times the sum of third and multiples of third harmonics that circulate in each phase.

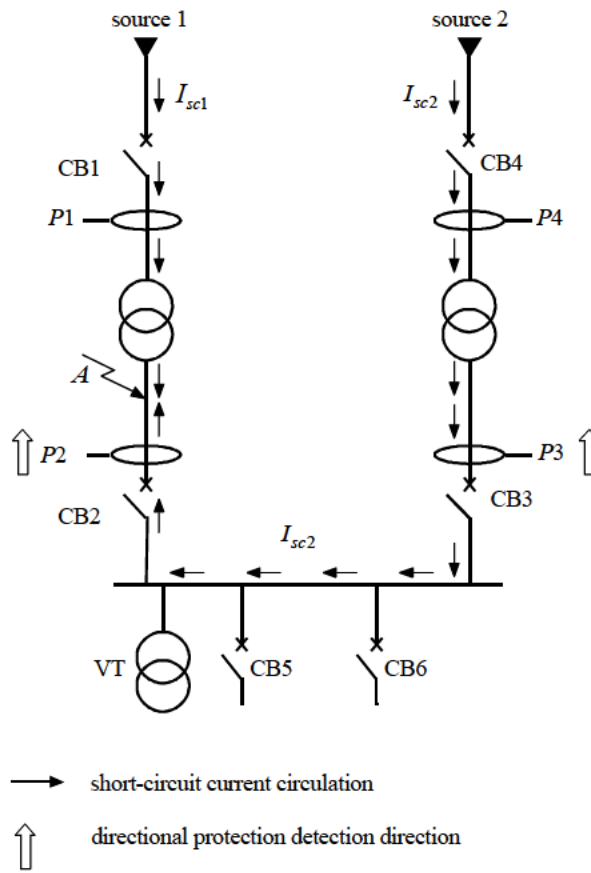
It is thus important to make protection insensitive to third and multiples of third harmonics so as not to cause spurious tripping.



**Figure 7-8:** the third harmonics of a three-phase system are in phase

**7.3. Directional overcurrent protection (ANSI code 67)**

This has a phase overcurrent function defined in section 7.1 associated with a “current direction” detection function. It is used, for example, when a busbar is fed by two sources (see Figure 7-9).



- $P1, P4$  : overcurrent protection devices
- $P2, P3$  : directional protection devices
- $I_{sc1}$  : short-circuit current fed by source 1
- $I_{sc2}$  : short-circuit current fed by source 2

**Figure 7-9: dual fed busbar**



When a fault occurs at  $A$ , the two short-circuit currents  $I_{sc1}$  and  $I_{sc2}$  are simultaneously established. A fault current flows through the four protection devices:  $P1$ ,  $P2$ ,  $P3$  and  $P4$ . Now in order to clear the fault without interrupting the power supply to the feeders, only circuit-breakers CB1 and CB2 must trip.

In order to do this, directional phase overcurrent protection devices are installed at  $P2$  and  $P3$ :

- Protection  $P3$  is not activated when a current circulating in the opposite direction to its detection direction flows through it.
- Protection  $P2$  is activated when a current circulating in its detection direction flows through it. It causes the circuit-breaker CB2 to trip and the current  $I_{sc2}$  is interrupted. An inter-tripping system causes CB1 to trip and the current  $I_{sc1}$  is interrupted.
- Protection  $P4$ , which is time delayed, is not activated.

The faulty section is thus isolated.

It is said that the protection detects the “direction of the current”; in reality it detects the sign of the active power. Thus, the phase displacement  $\varphi_{sc}$  between the voltage and the short-circuit current must be known.

The directional protection at  $P3$  detects a short-circuit current circulating from the transformer towards the busbar. The active power detected by the protection is positive:

$$-\frac{\pi}{2} \leq \varphi_{sc,P3} \leq \frac{\pi}{2} \text{ and } \cos \varphi_{sc,P3} \geq 0.$$

The directional protection at  $P2$  detects a short-circuit current circulating from the busbar towards the transformer. The active power detected by the protection is negative:

$$\frac{\pi}{2} \leq \varphi_{sc,P2} \leq \frac{3\pi}{2} \text{ and } \cos \varphi_{sc,P2} \leq 0.$$

To determine the phase displacement  $\varphi_{sc}$ , the current of one phase must be compared in relation to a polarizing voltage.

For a current in phase 1, the most frequently applied polarizing voltage is the phase-to-phase voltage between phases 2 and 3, i.e. the voltage perpendicular to the current  $I1$  for zero phase displacement (see Figure 7-10).

Similarly, for a current in phase 3, the polarizing voltage chosen is the phase-to-phase voltage between phases 1 and 2 (see Figure 7-11).

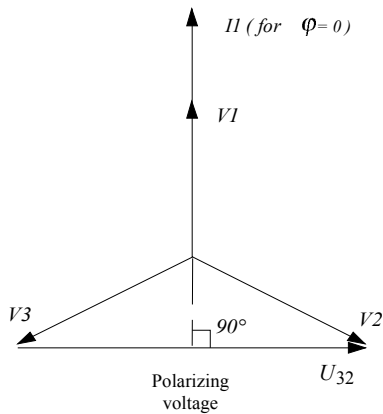


Figure 7-10: phase 1 polarizing voltage

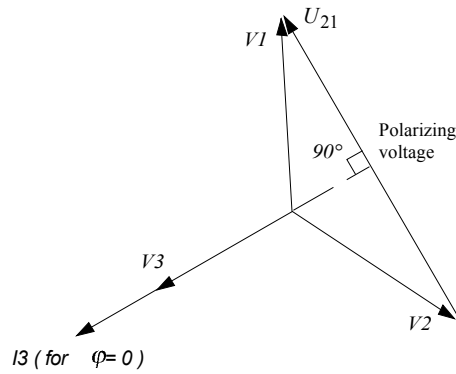


Figure 7-11: phase 3 polarizing voltage

The *protection connection angle* is said to be  $90^\circ$ .

Two relays are sufficient for the balanced three-phase short-circuit and the three phase-to-phase short-circuits to show up, for example, on phase 1 and on phase 3. Indeed, whatever the phase-to-phase short-circuit, it will concern either phase 1 or 3.

The choice of polarizing voltage is explained as follows.

For the current on phase 1:

- when a three-phase short-circuit occurs, the voltage detected by the protection is low, so it is better to use a phase-to-phase voltage;
- when a phase-to-phase short-circuit occurs between phases 1 and 2, the voltage  $U_{12}$  is very low, possibly zero, if the fault occurs close to the protection. Similarly, when a short-circuit between phases 1 and 3 occurs, the voltage  $U_{13}$  may be low and the phase-to-phase voltage  $U_{32}$  must therefore be taken to guarantee a sufficient voltage amplitude.

For the current on phase 3:

- using the same reasoning, the polarizing voltage is  $U_{21}$ .

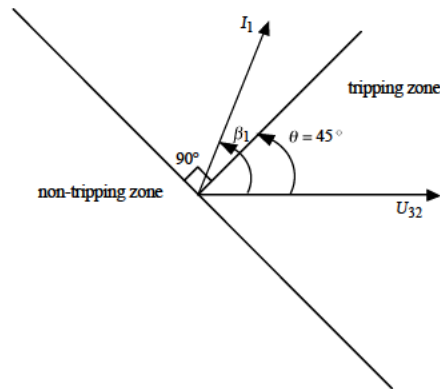
**7.3.1. Operation**

Directional phase overcurrent protection is activated if the following two conditions apply to a time equal to the time delay chosen:

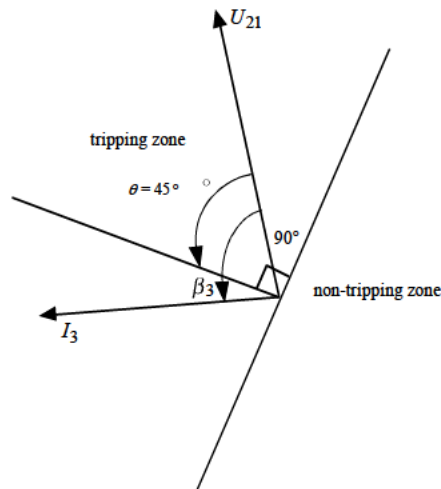
- the current is higher than the setting threshold;
- the current phase in relation to the polarizing voltage is in a range referred to as the tripping zone.

The protection tripping zone is a half plane. This half plane is defined by a characteristic angle  $\theta$ , which is the angle of the line perpendicular to the boundary line between the two zones and the polarization vector (see Figure 7-12 for  $\theta = 45^\circ$ ).

**a) phase 1**



**b) phase 3**



**Figure 7-12:** tripping zones of the directional protection for phases 1 and 3 with a characteristic angle  $\theta = 45^\circ$

The usual characteristic angle values are  $30^\circ$ ,  $45^\circ$  and  $60^\circ$ . The value generally used is  $45^\circ$  and we shall see why as follows.

We can see that the current  $I_1$  is:

- in the tripping zone for  $\theta - 90^\circ < \beta_1 < \theta + 90^\circ$
- in the non-tripping zone for  $\theta + 90^\circ < \beta_1 < \theta + 270^\circ$

$\beta_1$  is the angle between  $I_1$  and  $U_{32}$  and it corresponds to a phase displacement  $\varphi_1$  between  $I_1$  and  $V_1$  such that:  $\varphi_1 = \beta_1 + 90^\circ$ .

Similarly, the current  $I_3$  is:

- in the tripping zone for  $\theta - 90^\circ < \beta_3 < \theta + 90^\circ$
- in the non-tripping zone for  $\theta + 90^\circ < \beta_3 < \theta + 270^\circ$

$\beta_3$  is the angle between  $I_3$  and  $U_{21}$  and it corresponds to a phase displacement  $\varphi_3$  between  $I_3$  and  $V_3$  such that:  $\varphi_3 = \beta_3 + 90^\circ$ .

#### ***Why is a characteristic angle $\theta$ introduced?***

This angle is related to the natural phase displacement of the current in relation to the voltage when a short-circuit occurs. We shall study this phase displacement for two types of possible short-circuits: the symmetrical three-phase, and the phase-to-phase short-circuits.

#### *Phase displacement upon occurrence of a symmetrical three-phase short-circuit*

The network upstream of the short-circuit is equivalent to a resistor  $R$  in series with a reactor  $X$  and the ratio  $\frac{R}{X}$  is between 0.05 and 0.3 in MV (see section 4.1.1). The natural phase displacement  $\varphi$  between the voltage and the current for each phase is such that  $\text{tg } \varphi = \frac{X}{R}$   $\left( 3.3 < \frac{X}{R} < 20 \right)$ , hence  $73^\circ < \varphi < 87^\circ$ .

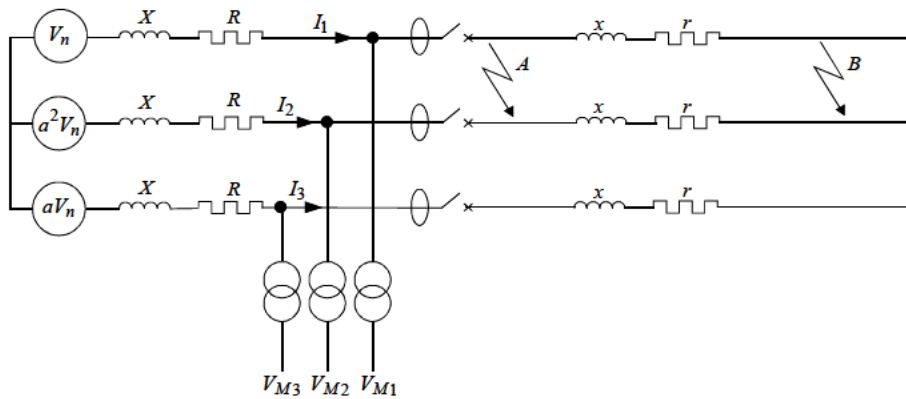
With the connection angle at  $90^\circ$ , the phase displacement  $\beta_1$  between  $I_1$  and  $U_{32}$  is:

$$\beta_1 = \varphi - 90^\circ \quad \Rightarrow \quad 3^\circ < |\beta_1| < 17^\circ$$

$\beta_1$  is negative and  $I_1$  therefore leads  $U_{32}$ .

*Phase displacement upon occurrence of a phase-to-phase short-circuit*

The electrical diagram of the network when a phase-to-phase short-circuit occurs between phases 1 and 2 is shown in Figure 7-13.



$X, R$ : upstream network impedance  
 $x, r$ : protected circuit impedance  
 $V_{M1}, V_{M2}, V_{M3}$ : voltages of phases 1, 2 and 3 measured by the voltage transformers located near the circuit-breaker

**Figure 7-13:** electrical diagram of the network when a phase-to-phase short-circuit occurs between phases 1 and 2

*Mathematical reminder:* let the rotation operator be  $\frac{2\pi}{3}$  such that  $V_2 = a^2 V_1$  and  $V_3 = a V_1$

$$a = e^{j\frac{2\pi}{3}} = -\frac{1}{2} + j\frac{\sqrt{3}}{2} \text{ and } a^2 = e^{j\frac{4\pi}{3}} = -\frac{1}{2} - j\frac{\sqrt{3}}{2}$$

giving the following relations:

$$1 + a + a^2 = 0 \quad \text{and} \quad a^3 = 1$$

$$j^2 = -1 \quad \text{and} \quad \frac{1}{j} = -j$$

*Case 1: short-circuit at A (see Figure 7-13)*

With the short-circuit being located just downstream of the voltage transformers, the voltages measured  $V_{M1}$  and  $V_{M2}$  are equal and therefore:

$$V_{M1} = V_{M2} = \frac{V_n + a^2 V_n}{2} = -a \frac{V_n}{2}$$

$$I_1 = -I_2 = \frac{V_n - a^2 V_n}{2(R + jX)} = \frac{V_n(1 - a^2)}{2(R + jX)}$$

$$V_{M3} = aV_n$$

thus:

$$U_{32} = V_{M2} - V_{M3} = -\frac{3}{2} a V_n$$

hence:

$$\frac{U_{32}}{I_1} = \frac{-3a}{1-a^2} (R + jX) = \frac{-3}{a^2 - a} (R + jX) = \frac{-3}{-j\sqrt{3}} (R + jX) = \sqrt{3} (-jR + X)$$

The phase displacement  $\beta_1$  between  $U_{32}$  and  $I_1$  is thus  $\beta_1 = -\text{Arctg} \frac{R}{X}$

where  $0.05 < \frac{R}{X} < 0.3$

then

$$3^\circ < |\beta_1| < 17^\circ$$

$\beta_1$  is negative and  $I_1$  therefore leads  $U_{32}$ .

We find that the phase displacement is identical to the symmetrical three-phase short-circuit.

*Case 2: short-circuit at B (see Figure 7-13)*

Let us take the extreme case where B is the point furthest away from the circuit-breaker and the voltage measuring devices. It is then assumed that  $X \ll x$  and  $R \ll r$ , i.e. that the impedance of the upstream network is negligible compared with the impedance of the protected circuit. The voltages measured are therefore not affected by the short-circuit.

Thus:

$$V_{M1} = V_n, \quad V_{M2} = a^2 V_n$$

and

$$V_{M3} = a V_n$$

since the voltage at the location point of the measuring device is not modified by the short-circuit, and

$$I_1 = -I_2 = \frac{V_n - a^2 V_n}{2(r + jx)} \text{ neglecting } X \text{ and } R \text{ in relation to } x \text{ and } r$$

thus:

$$U_{32} = V_{M2} - V_{M3} = (a^2 - a) V_n$$

hence:

$$\frac{U_{32}}{I_1} = \frac{(a^2 - a)}{(1 - a^2)} 2(r + jx) = \frac{-j\sqrt{3}}{\left(\frac{3}{2} + j\frac{\sqrt{3}}{2}\right)} 2(r + jx) = \frac{-2}{\left(\frac{1}{2} - j\frac{\sqrt{3}}{2}\right)} (r + jx)$$

$$\frac{U_{32}}{I_1} = -\left(\frac{1}{2} + j\frac{\sqrt{3}}{2}\right) 2(r + jx)$$

The argument of  $-\frac{1}{2} - j\frac{\sqrt{3}}{2}$  is  $-120^\circ$ .

The phase displacement between  $U_{32}$  and  $I_1$  is therefore

$$\beta_1 = -120^\circ + \text{Arctg} \frac{x}{r}.$$

$x$  and  $r$  are respectively the reactance and the resistance of the protected circuit (cable or line).

The value of  $\frac{x}{r}$  depends on the cross-section, the material of the conductor core and the type of link (cable or line).

We shall define two extreme values of the ratio  $\frac{x}{r}$  taking:

– an MV cable in 95 mm<sup>2</sup> Alu

$$x = 0.15 \Omega/km$$

and

$$r = \frac{\rho_{Alu}}{S} = \frac{29}{95} = 0.31 \text{ } \Omega/km \text{ (see section 4.2.1.4)}$$

hence

$$\frac{x}{r} = 0.48$$

– an overhead MV line in 240 mm<sup>2</sup> Alu

$$x = 0.3 \text{ } \Omega/km$$

and

$$r = \frac{\rho_{Alu}}{S} = \frac{29}{240} = 0.12 \text{ } \Omega/km$$

hence

$$\frac{x}{r} = 2.5$$

In the range defined by these two extreme values  $0.48 \leq \frac{x}{r} \leq 2.5$ , thus:

$$26^\circ < \text{Arctg} \frac{x}{r} < 68^\circ$$

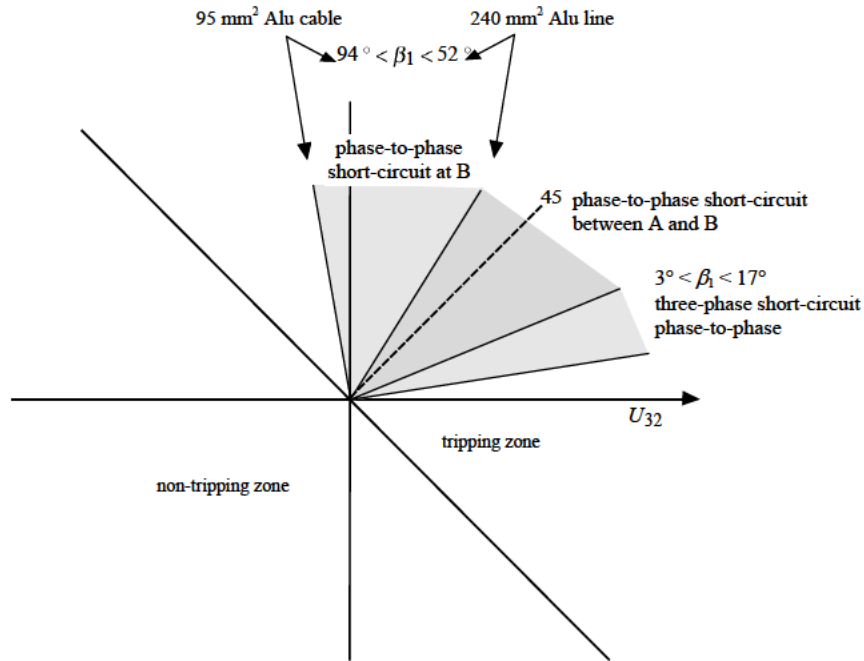
hence

$$52^\circ < |\beta_1| < 94^\circ$$

$\beta_1$  is negative and  $I_1$  therefore leads  $U_{32}$

The three-phase and phase-to-phase short-circuit current  $I_1$  zones can thus be defined in relation to  $U_{32}$  (see Figure 7-14).





**Figure 7-14:** *three-phase and phase-to-phase short-circuit current  $I_1$  zone in relation to  $U_{32}$*

We can see in Figure 7-14 that the short-circuit current  $I_1$  zone is on both sides of the line at a  $45^\circ$  angle to  $U_{32}$ . This is why a characteristic angle  $\theta$  is introduced, allowing the non-tripping zone “perpendicular” to the short-circuit zone to be defined.

We can see in Figure 7-14 that the setting  $\theta = 45^\circ$  is valid for all cases and it is the value generally used.

The setting values  $\theta = 30^\circ$  and  $\theta = 60^\circ$  correspond to the following particular applications:

- $\theta = 30^\circ$  may be suitable for links with a high  $\frac{x}{r}$  ratio, i.e. for cables with large cross-sections (see Figure 7-14);

–  $\theta = 60^\circ$  may be suitable for links with a low  $\frac{x}{r}$  ratio, i.e. for cables with small cross-sections (see Figure 7-14).

#### 7.4. Directional earth fault protection (ANSI code 67 N)

This has an earth function defined in section 7.2 associated with a “current direction” detection function.

The protection is activated when the amplitude of the residual current rises above the setting threshold and when its phase displacement in relation to a polarizing voltage is inside a pre-defined zone.

The polarizing voltage used is the residual voltage.

##### ***Residual current measurement***

The residual current is the vectorial sum of the currents of the 3 phases  $I_{rsd} = I_1 + I_2 + I_3$  (see section 7.2).

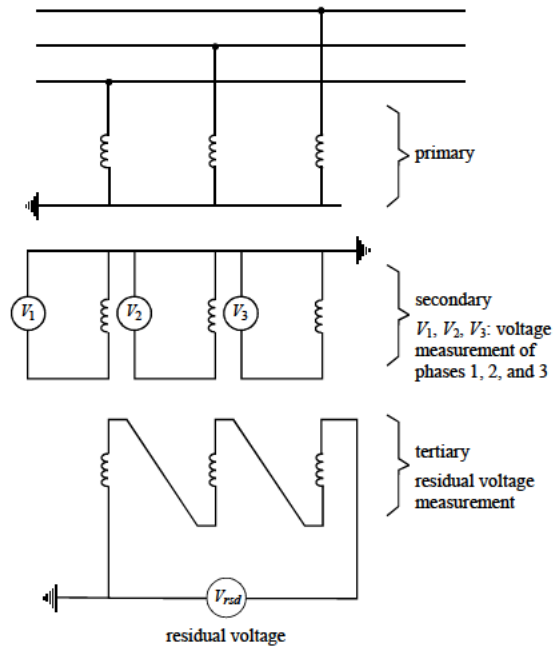
##### ***Residual voltage measurement***

The residual voltage is the vectorial sum of the phase-to-earth voltages 1, 2 and 3  $V_{rsd} = V_1 + V_2 + V_3$ .

The measurement can be carried out in one of the following two ways:

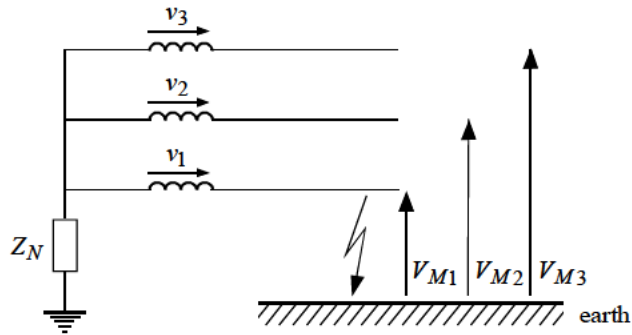
– Indirectly: using the phase-to-earth voltages 1, 2 and 3, a device performs the vectorial sum  $V_{rsd} = V_1 + V_2 + V_3$ .

– Directly: using three 3-coil voltage transformers. Each secondary is used to measure the voltage of each phase; the tertiary is connected in an open delta arrangement and at the terminals of this delta a residual voltage occurs (the sum of the voltages is performed “electrically”) (see Figure 7-15).



**Figure 7-15:** measurement of the residual voltage using three VTs with delta-connected tertiary

*Value of the residual voltage upon occurrence of a solid phase-to-earth fault for an unearthed, limiting impedance or Petersen coil earthed network (see Figure 7-16)*



$V_{M1}, V_{M2}, V_{M3}$ : phase-to-earth voltages measured in phases 1, 2 and 3

**Figure 7-16:** solid phase-to-earth fault

The phase-to-earth voltage measured in phase 1 is zero  $V_{M1} = 0$ .

The phase-to-earth voltage measured in phase 2 is the phase-to-phase voltage  $V_{M2} = V_2 - V_1$ .

The phase-to-earth voltage measured in phase 3 is the phase-to-phase voltage  $V_{M3} = V_3 - V_1$ .

The residual voltage  $V_{rsd}$  measured is thus:

$$\begin{aligned} V_{rsd} = V_{M1} + V_{M2} + V_{M3} &= 0 + V_2 - V_1 + V_3 - V_1 \\ &= V_1 + V_2 + V_3 - 3V_1 \\ &= -3V_1 \end{aligned}$$

as  $V_1 + V_2 + V_3 = 0$

### **Conclusion**

For a fault on any phase  $q$ , the residual voltage measured is  $V_{rsd} = -3V_q$ .

The amplitude of the residual voltage is therefore equal to three times the single-phase voltage upon occurrence of a solid phase-to-earth fault:

$$|V_{rsd}| = 3V_n$$

$V_n$ : nominal single-phase voltage

#### **7.4.1. Operation**

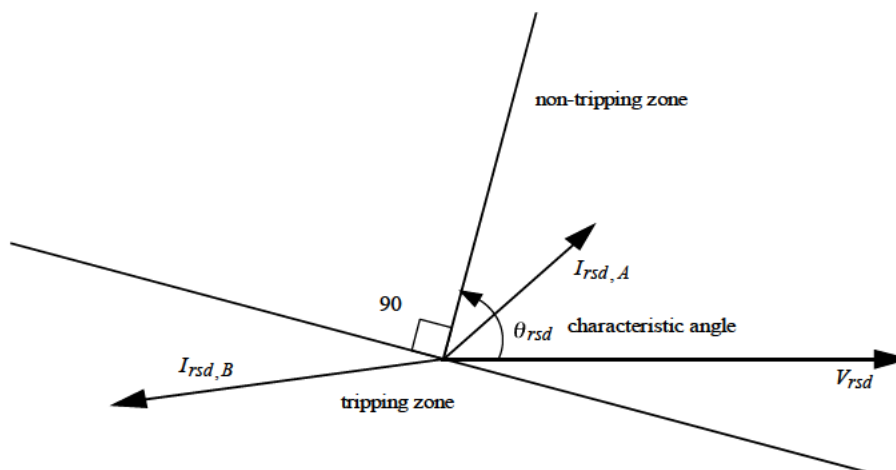
The directional earth fault protection is activated when the following two conditions apply for a period equal to the time delay chosen:

- the residual current is higher than the setting threshold;
- the residual current phase in relation to the residual voltage phase is in a range referred to as the tripping zone.

The protection tripping zone is a half plane.

This half plane is defined by a characteristic angle  $\theta_{rsd}$ , which is the angle of the line perpendicular to the boundary line between the two zones and the residual voltage (see Figure 7-17).

Polarization is therefore affected by the residual voltage.



**Figure 7-17:** *directional earth fault protection tripping zone*

The current  $I_{rsd,B}$  activates the protection whereas the current  $I_{rsd,A}$  does not.

#### ***Use of directional earth fault protection***

This is used in one of the following two ways:

- to detect the direction of the earth fault current;
- to distinguish between a fault current and a capacitive current. This is necessary when the network is:
  - unearthed;
  - earthed with a limiting resistance when the network is fairly widespread, thus leading to high capacitive currents upon occurrence of a phase-to-earth fault (see section 4.3.5).

It is not suitable for Petersen coil earthed networks.

#### ***Polarization by measuring the current in the neutral earthing connection***

In the case of limiting resistance earthing, polarization can be affected using the measurement of the current in the neutral earthing connection. Indeed, we saw in section 4.3 that for a phase-to-earth fault, the current circulating in the neutral earthing resistor is:

$$I_{neut} = -\frac{V_n}{R_N}$$

Thus:

$$I_{neut} = \frac{V_{rsd}}{3R_N}$$

where  $V_{rsd} = -3V_n$  for a solid fault.

The current circulating in the neutral earthing connection is thus proportional to  $V_{rsd}$ . Polarization can be affected by  $V_{rsd}$  or  $I_{neut}$ . In what follows,  $V_{rsd}$  will be used to help clarify explanations.

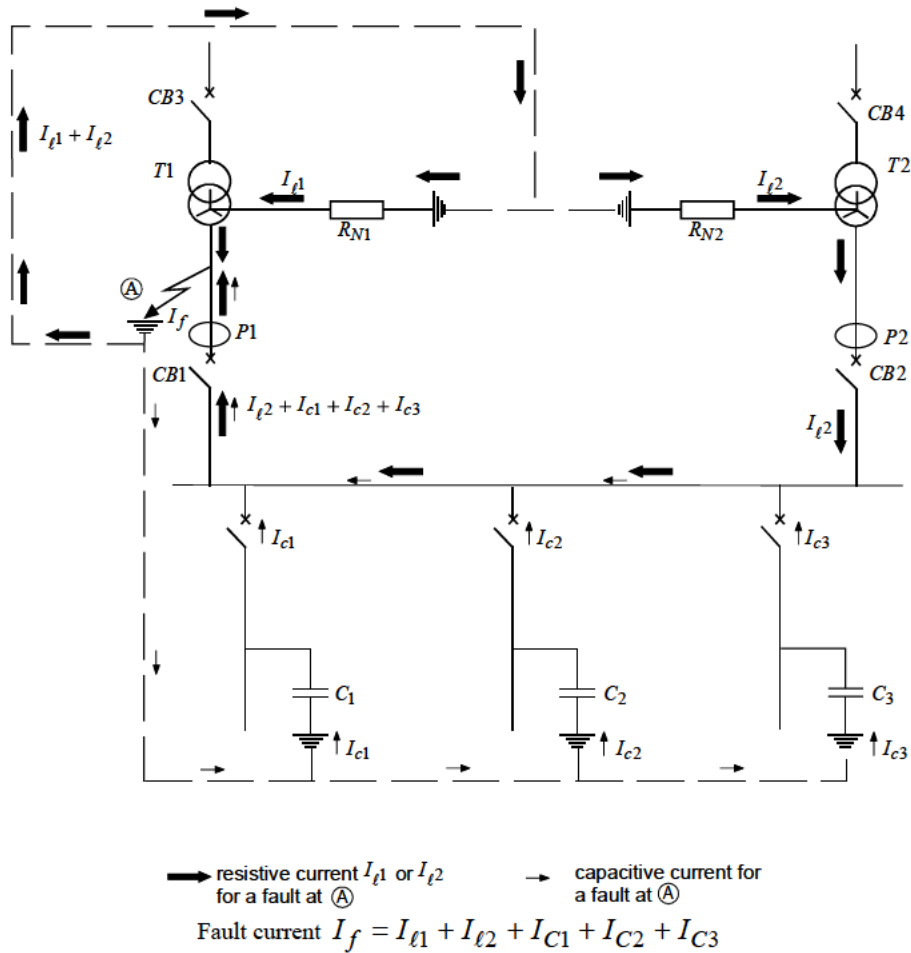
Polarization using the current circulating in the neutral earthing connection can be useful, especially in the following two cases:

- when it is more economical to measure this current than the residual voltage (a toroid costs less than 3 VTs);
- the neutral is earthed via a low impedance (fault current above 300 A), and the residual voltage is low in the event of a resistive fault. Polarization using the current circulating in the neutral earthing connection will therefore be more efficient than polarization by the residual voltage.

#### ***7.4.2. Study and setting of parameters for a network with limiting resistance earthing***

##### ***Use of directional earth fault protection to detect a fault current coming from downstream***

Let us consider the diagram in Figure 7-18.



**Figure 7-18:** detecting a fault current coming from downstream in a network with limiting resistance earthing

When a fault occurs at A, the two limiting currents  $I_{t1}$  and  $I_{t2}$  are simultaneously established. A fault current flows through protection devices P1 and P2.

To clear the fault without cutting off the feeder power supply, only circuit-breakers CB1 and CB3 must be tripped. To do this, directional earth fault protection devices must be installed at P1 and P2. They will allow circuit-breakers CB1 and CB3 to be tripped and circuit-breaker CB2 to remain closed.

*Determining the characteristic angle  $\theta_{rsd}$* 

The residual current value detected by protection *P1* is (see Figure 7-18):

$$I_{rsd1} = -(I_{\ell 2} + I_{C1} + I_{C2} + I_{C3})$$

where  $I_{\ell 2} = \frac{V_n}{R_{N2}}$

and

$$I_{Ci} = 3 j C_i \omega V_n$$

thus:

$$I_{rsd1} = -\frac{V_n}{R_{N2}} - 3 j (C_1 + C_2 + C_3) \omega V_n$$

$$I_{rsd1} = \frac{V_{rsd}}{3 R_{N2}} + j (C_1 + C_2 + C_3) \omega V_{rsd}$$

where  $V_{rsd} = -3 V_n$  for a solid fault

$C_i$  : feeder *i* capacitance

$V_n$  : nominal single-phase voltage

$R_{N2}$  : transformer *T2* limiting resistance

The residual current value detected by protection *P2* is (see Figure 7-18):

$$I_{rsd2} = I_{\ell 2}$$

where  $I_{\ell 2} = \frac{V_n}{R_{N2}}$

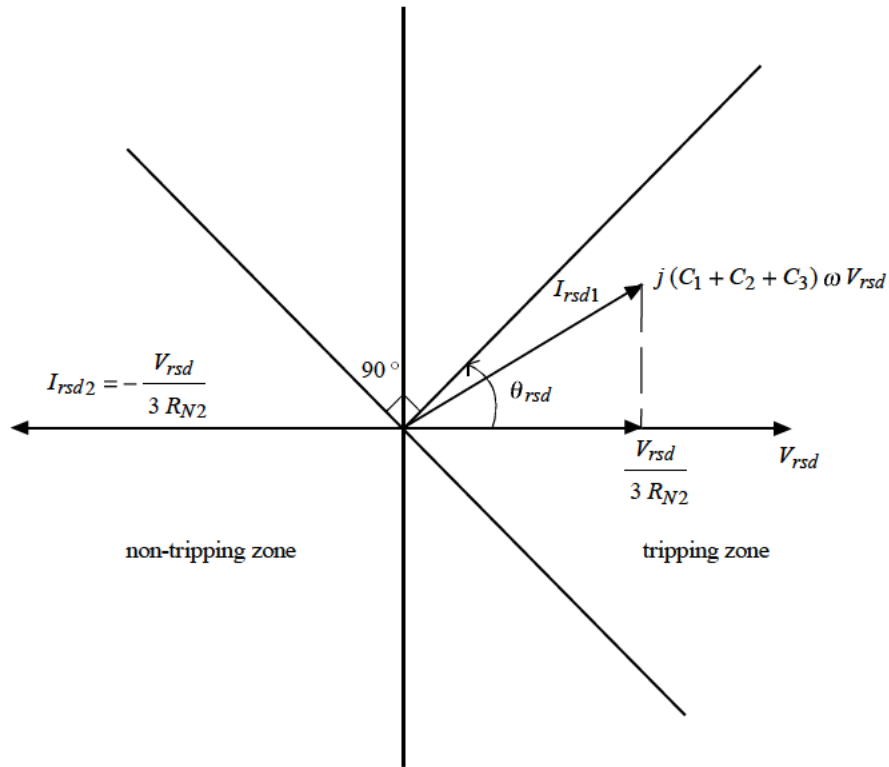
thus

$$I_{rsd2} = -\frac{V_{rsd}}{3 R_{N2}}$$

where  $V_{rsd} = -3 V_n$  for a solid fault.

The phase displacements between residual current and residual voltage detected by protection devices *P1* and *P2* can thus be established (see Figure 7-19).





**Figure 7-19:** phase displacements between residual current and residual voltage detected by protection devices P1 and P2

The phase displacement between residual current and residual voltage detected by protection P1 depends on the capacitive current value of all the feeders in relation to the limiting current.

In order to have the most stable protection possible,  $\theta_{rsd}$  is chosen such that the boundary line defining the two zones is perpendicular to  $I_{rsd1}$ .

Thus, if  $I_C$  is the capacitive current of all the feeders, we could for example choose  $\theta_{rsd}$  in the following way:

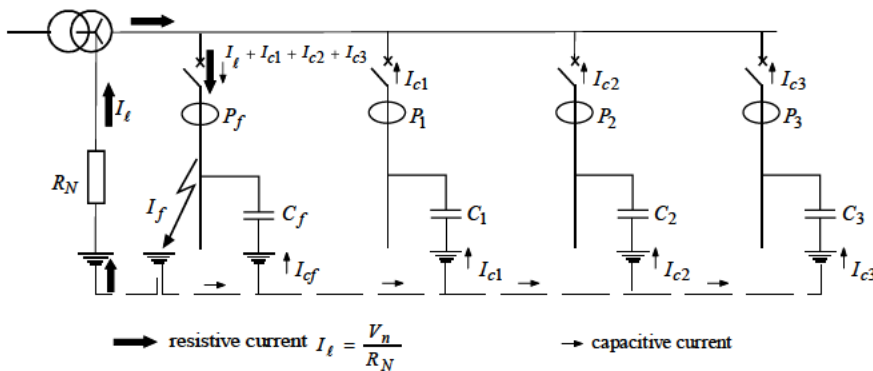
$$\begin{aligned}
 I_C < I_\ell & \Rightarrow \theta_{rsd} = 30^\circ \text{ or } 15^\circ \\
 I_C \text{ approximately equal to } I_\ell & \Rightarrow \theta_{rsd} = 45^\circ \\
 I_C > I_\ell & \Rightarrow \theta_{rsd} = 60^\circ
 \end{aligned}$$

*Current threshold setting:* this is set as low as possible in accordance with the minimum threshold (see section 7.2).

**Using directional earth fault protection to distinguish between a fault current and a capacitive current**

Section 4.3.5 studies the way earth fault currents spread out in a network with several outgoing feeders.

Let us consider the diagram in Figure 7-20.



Fault current  $I_f = I_t + I_{Cf} + I_{C1} + I_{C2} + I_{C3}$

**Figure 7-20:** distinguishing between a fault current and a capacitive current in a limiting resistance earthing system

A current caused by the cable capacitances flows through the healthy feeders.

The directional earth fault protection distinguishes between a current from a faulty feeder and a capacitive current from a healthy feeder.

*Determining the characteristic angle  $\theta_{rsd}$*

The residual current value detected by the protection *Pf* of the faulty feeder is (see Figure 7-20):

$$I_{rsdf} = I_t + I_{C1} + I_{C2} + I_{C3}$$

where  $I_\ell = \frac{V_n}{R_N}$

and

$$I_{Ci} = 3jC_i \omega V_n$$

thus:

$$I_{rsdf} = \frac{V_n}{R_N} + 3j(C_1 + C_2 + C_3) \omega V_n$$

$$I_{rsdf} = -\frac{V_{rsd}}{3R_N} - j(C_1 + C_2 + C_3) \omega V_{rsd}$$

where:

$V_{rsd} = -3V_n$  for a solid fault

$C_i$  : feeder  $i$  capacitance

$V_n$  : nominal single-phase voltage

$R_N$  : limiting resistance

The residual current value detected by the protection  $P_i$  of a healthy feeder is (see Figure 7-20):

$$I_{rsdi} = -I_{Ci}$$

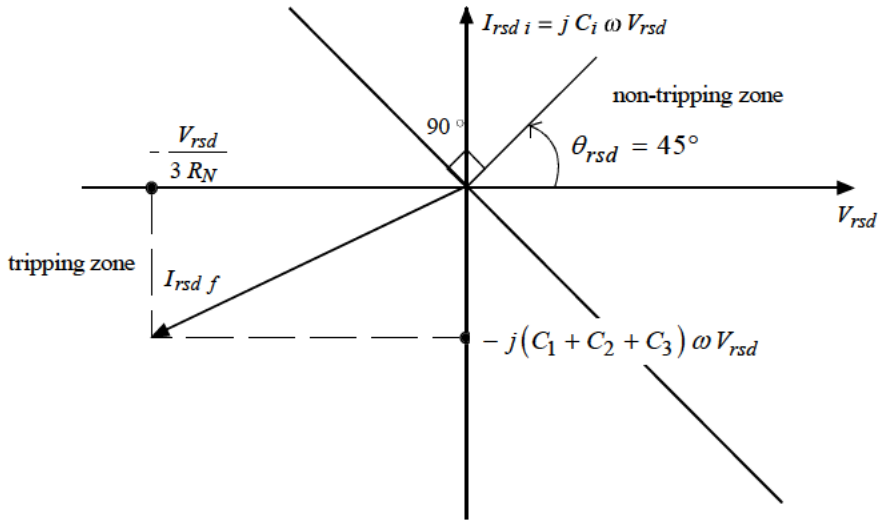
thus:

$$I_{rsdi} = -3jC_i \omega V_n$$

$$I_{rsdi} = jC_i \omega V_{rsd}$$

where  $V_{rsd} = -3V_n$  for a solid fault.

The phase displacements between residual current and residual voltage detected by the faulty feeder protection and healthy feeder protection devices can thus be established (see Figure 7-21).



**Figure 7-21:** phase displacements between residual current and residual voltage detected by the faulty feeder protection and the healthy feeder protection devices

The phase displacement between residual current and residual voltage detected by the protection  $P_f$  of the faulty feeder depends on the capacitive current value of all the healthy feeders in relation to the value of the limiting current.

The value  $\theta_{rsd}$  is chosen so that spurious tripping does not occur, and so that the faulty feeder is tripped whatever the network configuration, i.e. for a variable capacitive current of the healthy feeders.

In general,  $\theta_{rsd} = 45^\circ$  is applied.

*Current threshold setting:* this is set as low as possible, i.e. in accordance with the minimum threshold (see section 7.2).

#### 7.4.3. Study and setting of parameters for an unearthed network

##### *Using directional earth fault protection to detect a fault current coming from downstream*

This type of protection is rarely used in unearthed neutral systems.

For a network with two parallel incoming feeders, the length of the incoming links is generally fairly short. The capacitive currents of these links are therefore low compared with those of the feeders. Thus, it is not useful to install directional earth fault protection devices to obtain selectivity between the two incoming feeders: for example, see section 10.1.5.2, Figure 10-11.

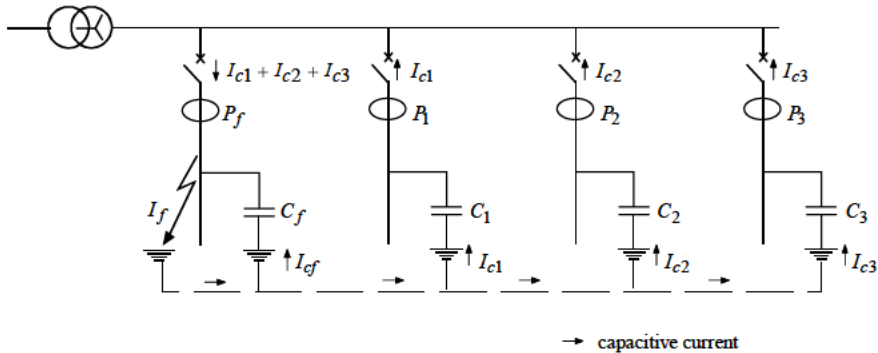
In the case of a network with two long parallel incoming feeders, directional earth fault protection must be installed. It allows the direction of capacitive currents to be detected and tripping on the healthy incoming feeder link to be avoided. The characteristic angle must therefore be set at  $90^\circ$  since the fault currents are only capacitive.

Another case where it is used is for a network with two incoming feeders in a loop arrangement (see section 10.1.6.2, Figure 10-15). Directional protection devices are combined with a logical exchange system. The currents detected by the protection devices are only capacitive and the characteristic angle  $\theta_{rsd}$  is thus set at  $\pm 90^\circ$ , depending on the detection direction required.

**Using directional earth fault protection to distinguish between a fault current and a capacitive current**

Section 4.3.5 looks at how earth fault currents spread out in a network with several outgoing feeders.

Let us consider the diagram in Figure 7-22.



Fault current  $I_f = I_{Cf} + I_{C1} + I_{C2} + I_{C3}$

**Figure 7-22:** distinguishing between a fault current and a capacitive current in an ungrounded neutral system

A current due to the capacitance of the cables flows through the healthy feeders.

The directional earth fault protection distinguishes between the capacitive current from a faulty feeder and the capacitive current from a healthy feeder.

*Determining the characteristic angle  $\theta_{rsd}$*

The residual current value detected by the protection  $Pf$  of the faulty feeder is (see Figure 7-22):

$$I_{rsdf} = I_{C1} + I_{C2} + I_{C3}$$

where  $I_{Ci} = 3jC_i\omega V_n$

thus

$$I_{rsdf} = 3j(C_1 + C_2 + C_3)\omega V_n$$

$$I_{rsdf} = -j(C_1 + C_2 + C_3)\omega V_{rsd}$$

where:

$$V_{rsd} = -3V_n \text{ for a solid fault}$$

$C_i$  : feeder  $i$  capacitance

$V_n$  : nominal single-phase voltage

The residual current value detected by the protection  $Pi$  of a healthy feeder is (see Figure 7-22):

$$I_{rsdi} = -I_{Ci}$$

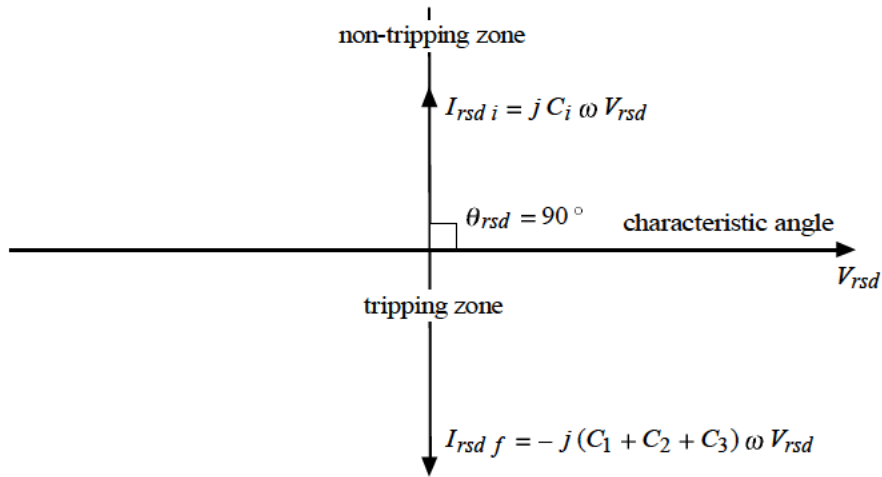
thus:

$$I_{rsdi} = -3jC_i\omega V_n$$

$$I_{rsdi} = jC_i\omega V_{rsd}$$

where  $V_{rsd} = -3V_n$  for a solid fault.

The phase displacements between residual current and residual voltage detected by the faulty feeder protection and healthy feeder protection devices can thus be established (see Figure 7-23).



**Figure 7-23:** phase displacements between residual current and residual voltage detected by the faulty feeder protection and healthy feeder protection devices

In Figure 7-23, we can see that the characteristic angle  $\theta_{rsd}$  must be set at  $90^\circ$ .

*Current threshold setting:* this is set as low as possible, i.e. in accordance with the minimum threshold when measurement is carried out using a core balance,  $I_{set} = 1\ A$  (see section 7.2).

*Requirements concerning the capacitive current values of feeders*

The residual current amplitude detected by the protection  $P_f$  of the faulty feeder is:

$$|I_{rsdf}| = 3 (C_1 + C_2 + C_3) \omega V_n$$

Whatever the network configuration, care must be taken to make sure that, for a fault occurring on any of the feeders, the sum of capacitances of all the other feeders leads to a capacitive current that is higher than the setting threshold.

Consequently, when the feeders are all short, it is not possible to select one feeder from the others owing to the minimum setting threshold ( $I_{set} = 1\ A$ ).

#### **Example**

Let us take the example of a 5.5 kV medium voltage network with single-core cables. The zero-sequence capacitance per unit of length is:

$$C_\ell \cong 0.5\ \mu F/km \quad (\text{see section 4.2.2.1})$$

Let us assume that the protection setting threshold is at the minimum, i.e.  $I_{set} = 1 \text{ A}$ .

To have at least 1 A of capacitive current, a minimum cable length  $L_{min}$  is required such that:

$$I_C = 1 \text{ A} = 3 C_\ell \omega L_{min} \frac{U_n}{\sqrt{3}}$$

$$L_{min} = \frac{\sqrt{3}}{3 \times 0.5 \times 10^{-6} \times 314 \times 5,500} = 0.67 \text{ km} = 670 \text{ m}$$

Care must therefore be taken to make sure that, whatever the network configuration with N feeders, the length of N-1 feeders is above 670 m. This condition allows selectivity between feeders to be obtained.

Note: when this condition is not met, an automatic device that successively trips each feeder and tests the PIM (Permanent Insulation Monitor; see section 2.4.1) or the residual overvoltage protection (see section 7.16) can be installed to determine the faulty feeder. However, this is not advisable because it leads to switching on healthy feeders and overvoltages that have the ability to cause a double fault.

### 7.5. Directional earth fault protection for compensated neutral networks (ANSI code 67 N)

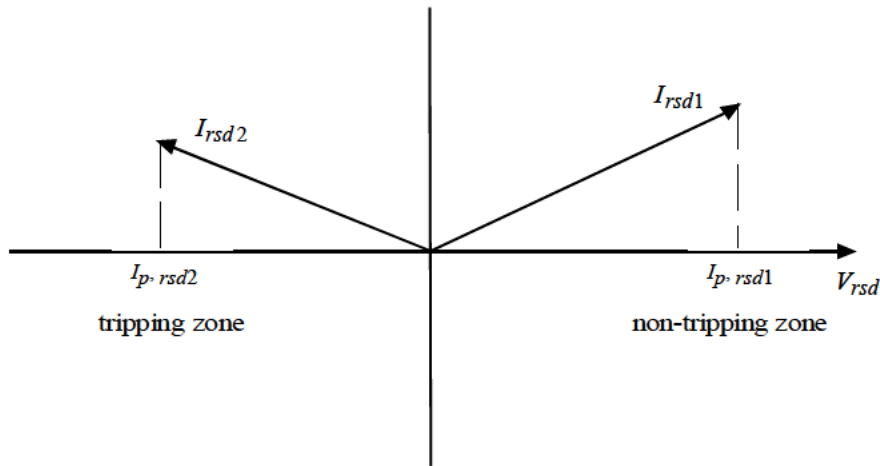
Protection is activated when the following two conditions apply for a period equal to the time delay chosen:

- the active component of the residual current is higher than the setting threshold;
- this component is in the detection direction chosen.

In Figure 7-24, the detection direction is the opposite direction to the residual voltage.

The “active” component of the residual current is the projection of the residual current onto the line defined by the residual voltage.





**Figure 7-24:** directional earth fault protection tripping zone for a compensated neutral network

The current  $I_{rsd2}$  activates protection whereas the current  $I_{rsd1}$  does not activate it.

This protection is used to protect feeders in a network with a Petersen coil earthing system (compensated neutral network). It enables the distinction between a current from a faulty feeder and a capacitive current from a healthy feeder.

For detail about the residual current and residual voltage measuring method and the value of the residual voltage upon occurrence of a solid phase-to-earth fault, refer to sections 7.2 and 7.4.

Section 4.3.3 studies the value of the earth fault current in a network with a Petersen coil earthing system.

Thus:

$$I_f = j \left( 3C\omega - \frac{1}{L_N\omega} \right) V_n$$

$I_f$  : earth fault current

$C$  : total network capacitance

$L_N$  : inductance of the Petersen coil located on the neutral

$V_n$  : nominal single-phase voltage

The fault current does not have an “active” component and therefore the protection cannot be operational.

In practice, in order to detect an “active” current component upon occurrence of a fault, a resistor is added in parallel with the coil (see Figure 7-25).

The resistor has a high value so that the fault current can be held at several amps only.

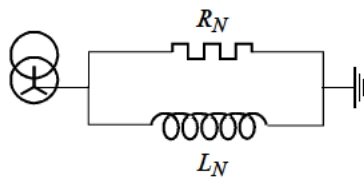
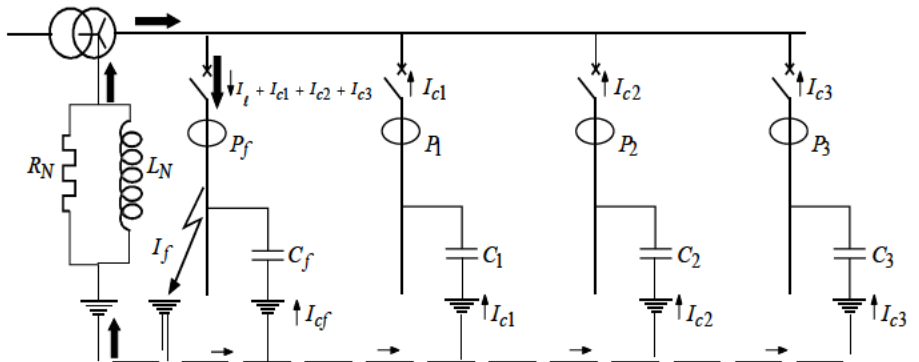


Figure 7-25: resistor in parallel with the Petersen coil

Let us consider the diagram in Figure 7-26.



- capacitive current
- limiting current via the Petersen coil in parallel with the resistance

$$I_{\ell} = V_n \left( \frac{1}{R_N} + \frac{1}{jL_N \omega} \right)$$

Fault current  $I_f = I_{\ell} + I_{Cf} + I_{C1} + I_{C2} + I_{C3}$

Figure 7-26: distinguishing between a fault current and a capacitive current in a compensated neutral network

A current caused by the capacitance of the cables flows through the healthy feeders. Directional earth fault protection for networks with a compensated neutral enables the distinction between a current from a faulty feeder and a capacitive current from a healthy feeder.

The residual current value detected by the protection  $Pf$  of the faulty feeder is (see Figure 7-26):

$$I_{rsdf} = I_\ell + I_{C1} + I_{C2} + I_{C3}$$

$$\text{where } I_\ell = V_n \left( \frac{1}{R_N} + \frac{1}{j L_N \omega} \right)$$

and

$$I_{Ci} = 3 j C_i \omega V_n$$

thus:

$$I_{rsdf} = \frac{V_n}{R_N} + j \left[ 3 (C_1 + C_2 + C_3) \omega - \frac{1}{L_N \omega} \right] \quad (\text{reminder } \frac{1}{j} = -j)$$

$$I_{rsdf} = -\frac{V_{rsd}}{3 R_N} - j \left[ (C_1 + C_2 + C_3) \omega - \frac{1}{3 L_N \omega} \right] V_{rsd}$$

where  $V_{rsd} = -3 V_n$  for a solid fault.

$C_i$  : feeder  $i$  capacitance

$L_N$  : inductance of the compensation coil located on the neutral

$R_N$  : limiting resistance located on the neutral

$V_n$  : nominal single-phase voltage

If tuning is achieved,  $(C_1 + C_2 + C_3) \omega - \frac{1}{3 L_N \omega}$  is approximately zero.

The projection of the current  $I_{rsdf}$  on the line defined by the residual voltage  $V_{rsd}$  is:

$$I_{p,rsdf} = -\frac{V_{rsd}}{3 R_N}$$

The residual current value detected by the protection  $P_i$  of a healthy feeder is (see Figure 7-26):

$$I_{rsdi} = -I_{Ci}$$

let

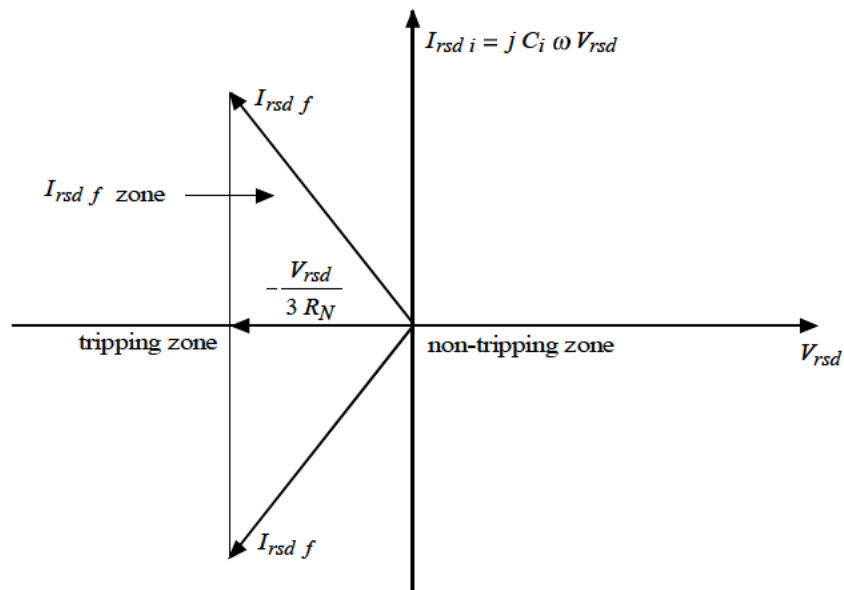
$$I_{rsdi} = -3 j C_i \omega V_n$$

$$I_{rsdi} = j C_i \omega V_{rsd}$$

where  $V_{rsd} = -3 V_n$  for a solid fault.

The projection of the current  $I_{rsdi}$  on the line defined by the residual voltage  $V_{rsd}$  is zero.

The phase displacements between residual current and residual voltage detected by the faulty feeder protection and healthy feeder protection devices can thus be established (see Figure 7-27).



**Figure 7-27:** phase displacements between residual current and residual voltage detected by the healthy feeder protection and faulty feeder protection devices

The current  $I_{rsdf}$  may be located above or below the line defined by  $V_{rsd}$  and have a large amplitude that is greater or smaller according to the quality of tuning between the coil and network capacitance.

Since the capacitance varies in accordance with the network configuration or implementation of new links, tuning is never perfect.

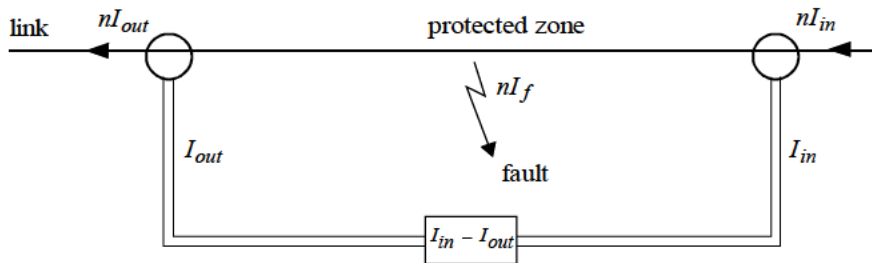
To make it as good as possible, it is preferable to install a variable inductance coil.

*Current threshold setting:* this is set as low as possible, in accordance with the minimum threshold (see section 7.2).

Note: the possible  $I_{rsdf}$  zone is close to  $I_{rsdi}$  (see Figure 7-27), which is why directional earth fault protection cannot be used because it may cause spurious tripping.

**7.6. Differential protection**

The principle of differential protection consists of comparing two currents from the same phase that are normally equal. If the current entering into the protected zone is not equal to the current leaving this zone, the current differences at the ends of the protected zone give the fault current measurement (see Figure 7-28):



**Figure 7-28:** block diagram of differential protection

$I_{in} - I_{out} = I_f$  fault current measurement

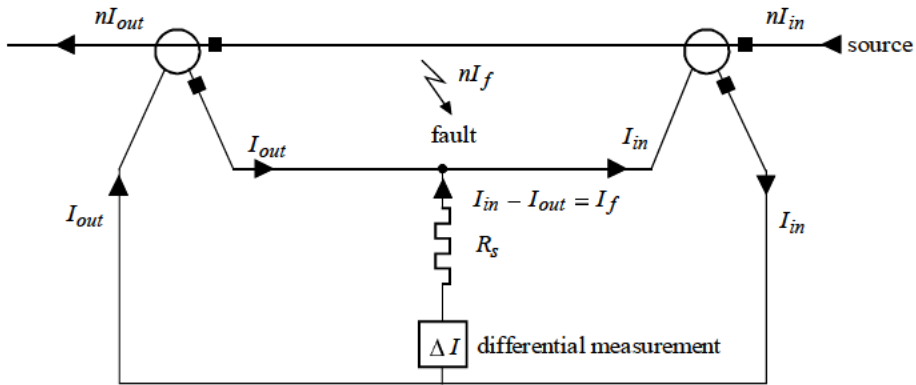
$I_{in}$  : measurement of the current entering the protected zone

$I_{out}$  : measurement of the current leaving the protected zone

$n$  : CT transformation ratio

**7.6.1. High impedance differential protection**

*Principle (see Figure 7-29)*



- current entering on the primary side and leaving on the secondary side, corresponding to  $P1, S1$

**Figure 7-29: high impedance differential protection**

The CT secondaries are connected so that they flow into one another. Therefore, they are phase opposition mounted and in normal operating conditions  $I_{in} = I_{out}$ .

The current measured in the differential branch is approximately zero in normal operating conditions or when the fault occurs outside the zone. It is proportional to the fault current when this occurs inside the protected zone.

This diagram can be used for phase-to-phase faults (two-phase or three-phase) and phase-to-earth faults with one differential branch per phase (see Figure 7-30), or it can be used only for phase-to-earth faults by connecting the three phases so that the summation of currents of each phase is affected (see Figure 7-31). The residual current  $I_{rsd}$  is the sum of the currents of the 3 phases and it corresponds to the current flowing through earth (see section 7.2, under the heading “Residual current measurement”).

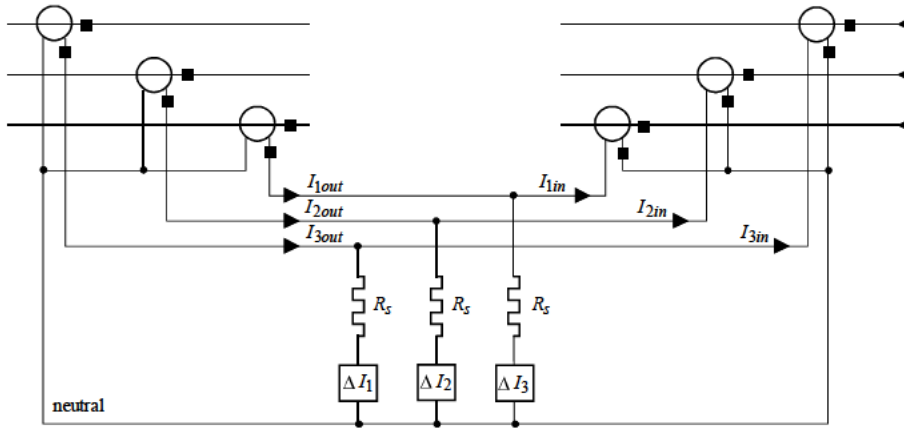


Figure 7-30: protection against phase-to-phase and phase-to-earth faults

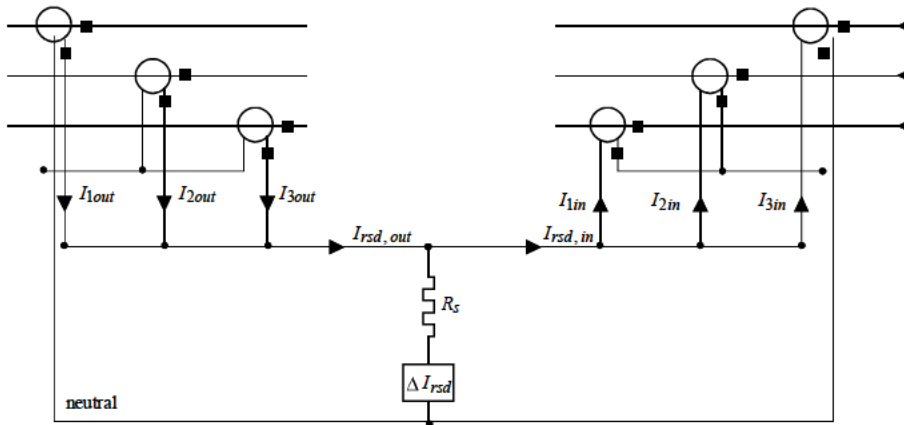


Figure 7-31: protection against phase-to-earth faults

$I_{1in}$ ,  $I_{2in}$ ,  $I_{3in}$  : measurement of the currents of phases 1, 2 and 3 entering the protected zone

$I_{1out}$ ,  $I_{2out}$ ,  $I_{3out}$  : measurement of the currents of phases 1, 2 and 3 leaving the protected zone

$I_{rsd,in}$  : measurement of the residual current entering the protected zone

$I_{rsd,out}$  : measurement of the residual current leaving the protected zone

### 7.6.1.1. Operation and dimensioning of elements

The operation of high impedance differential protection would not be a problem if the secondary currents supplied by the currents' transformers were exactly the same as the primary currents at every moment.

However, current transformers can saturate when a short-circuit occurs outside the protected zone, even if the short-circuit current value is lower than the accuracy limit factor (see section 6.1.3.5) or if the secondary voltage corresponding to this current is lower than the knee-point voltage (see section 6.1.3.6).

Indeed, the short-circuit current has an aperiodic component (see section 4.1.1), which has a maximum value of approximately 40 to 80% of the peak value of the AC component and lasts between 50 to 100 ms. This (decreasing exponential) aperiodic component favors saturation of the magnetic circuit.

Indeed, the magnetic induction  $B(t)$  is proportional to  $\int I_{sc}(t) dt$  (see section 6.1.2). The aperiodic component integral will make  $B$  increase beyond the saturation limit (see Figure 6-4).

Saturation may cause spurious tripping of the protection, as we shall see.

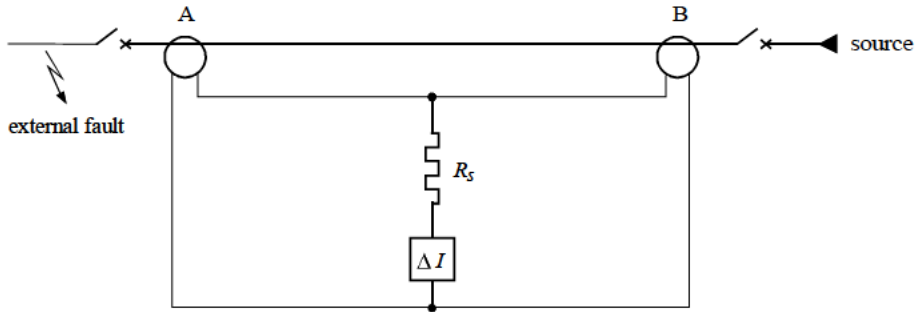
When a fault occurs outside the protected zone, the current transformers at each end detect the fault and may be affected by the saturation. The current transformer specifications cannot be perfectly identical. One may be saturated more or less than the other or not be saturated at all, which leads to a difference of current  $I_{in} - I_{out} \neq 0$  flowing in the differential branch and may cause spurious activation of the protection.

#### ***Incorporation of a stabilizing resistor in the differential branch***

To overcome the problem of spurious tripping, care must be taken to make sure that, in the event of saturation of one or both of the current transformers upon occurrence of a short-circuit outside the protected zone, the current flowing in the differential branch is lower than the protection setting threshold. To do this, a resistor  $R_s$  is incorporated in the differential branch (see Figure 7-32) to increase the circuit impedance.

In the following calculations the relay resistance is included in the stabilizing resistance so that the equations are not too long. The relay resistance is generally negligible.





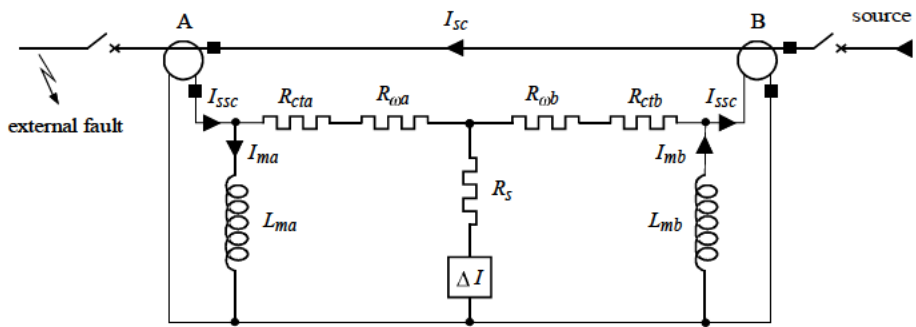
$R_S$  : stabilizing resistor

**Figure 7-32a:** incorporation of a stabilizing resistor in the differential branch

Let us consider the most problematic case: a fault appears outside the protected zone and one of the current transformers saturates, whereas the other does not.

Let us assume, for example, that B is saturated and that A supplies a secondary current that has exactly the same value as the primary current.

Let us look again at the diagram in Figure 7-32a, adding the equivalent diagram of the current transformers (see section 6.1.1) and resistance of the connecting wires linking the CT to the differential branch. The inductance of the connecting wires can be neglected because they have a small cross-sectional area dimensioned for a current lower than 5 A ( $L_w \omega \ll R_w$ ). Therefore, this gives us the electrical diagram shown in Figure 7-32b.



**Figure 7-32b:** equivalent diagram of the current transformers and connecting wires

where  $R_{cta}$ ,  $R_{ctb}$ : resistance of A and B current transformer windings.

$R_{wa}, R_{wb}$  : resistance of the wires linking A and B current transformers to the differential branch

$I_{ma}, I_{mb}$  : magnetizing current of A and B current transformers

$L_{ma}, L_{mb}$  : magnetizing inductance of A and B current transformers

$I_{ssc}$  : maximum short-circuit current recalculated for the secondary of the current transformers

Let us simplify the electrical diagram using the following hypotheses:

- transformer B is saturated; its magnetizing current is very high and therefore its magnetizing inductance tends towards zero (see section 6.1.2). We shall take it as being equal to zero;
- transformer A is not saturated; its magnetizing current is very low and its magnetizing inductance is therefore very high. We shall take it as being infinite.

Therefore, this gives us the simplified equivalent diagram shown in Figure 7-33.

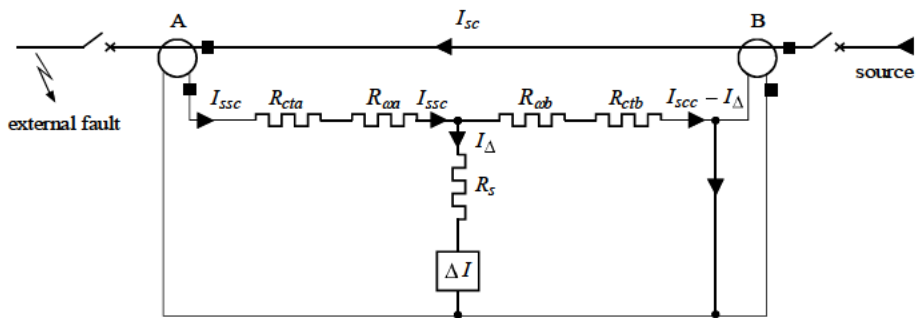


Figure 7-33: equivalent diagram when B is saturated and A is not saturated

The current flowing into the differential branch is:

$$I_{\Delta} = \frac{R_{wb} + R_{ctb}}{R_s + R_{wb} + R_{ctb}} I_{ssc}$$

(formula of the current divider between parallel impedances  $R_s$  and  $R_{wb} + R_{ctb}$ ).

Let  $I_{set}$  be the protection setting threshold.

So as not to provoke spurious tripping upon occurrence of a short-circuit outside the protected zone, the following condition must apply:

$$I_{set} \geq I_{\Delta}$$

thus:

$$I_{set} \geq \frac{R_{wb} + R_{ctb}}{R_s + R_{wb} + R_{ctb}} I_{ssc}$$

$$R_s + R_{wb} + R_{ctb} \geq (R_{wb} + R_{ctb}) \frac{I_{ssc}}{I_{set}}$$

The ratio  $\frac{I_{ssc}}{I_{set}}$  is very important and is approximately 100.

Note 1: for a maximum short-circuit current  $I_{ssc}$  equal to 20 times the nominal current  $I_{sn}$ , and a protection setting threshold  $I_{set} = 20\% I_{sn}$ , then  $\frac{I_{ssc}}{I_{set}} = \frac{20 I_{sn}}{0.2 I_{sn}} = 100$ . A resistance  $R_s$  that is far higher than  $R_{wb} + R_{ctb}$  is thus determined.

Note 2: for the same conditions as Note 1, we find

$$R_s + R_{wb} + R_{ctb} \geq (R_{wb} + R_{ctb}) \times 100$$

thus

$$R_s \geq (R_{wb} + R_{ctb}) \times 99.$$

The high value of  $R_s$  in relation to  $R_{wb} + R_{ctb}$  justifies the term “*high impedance differential protection*”.

As stated in Note 2, in practice  $R_s$  is far higher than  $R_{wb} + R_{ctb}$ , thus  $R_{wb} + R_{ctb}$  is neglected compared with  $R_s$ .

The condition that must apply in order to avoid spurious tripping therefore becomes:

$$R_s \geq (R_{wb} + R_{ctb}) \frac{I_{ssc}}{I_{set}}$$

If we use the same reasoning in the case where A is saturated and B is not, we obviously arrive at the same type of condition:

$$R_s \geq (R_{wa} + R_{cta}) \frac{I_{ssc}}{I_{set}}$$

The stabilizing resistance must therefore be chosen so that the following condition applies:

$$R_s \geq (R_w + R_{ct}) \frac{I_{ssc}}{I_{set}}$$

where  $R_w + R_{ct}$  is equal to the maximum value of  $R_{wa} + R_{cta}$  and  $R_{wb} + R_{ctb}$

$$R_w + R_{ct} = \max (R_{wa} + R_{cta}, R_{wb} + R_{ctb})$$

The value of  $R_s$  is between several Ohms and several hundred Ohms.

In practice, we shall take

$$R_s = (R_w + R_{ct}) \frac{I_{ssc}}{I_{set}}$$

as it is preferable that the value of  $R_s$  be as low as possible. Indeed, as we shall see in the next paragraph, the value of  $R_s$  dimensions the current transformer.

### ***Dimensioning current transformers***

Care must be taken to make sure that current transformers are dimensioned so that the voltage at the terminals of the differential branch is sufficient to activate protection in the event of a fault occurring in the protected zone.

Let us now study the case of a solid fault inside the protected zone.

The equivalent diagram is that shown in Figure 7-34 before any eventual saturation occurs.

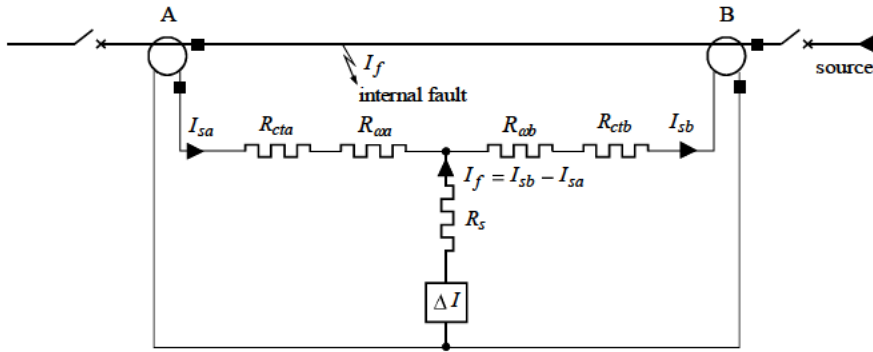


Figure 7-34: equivalent diagram for a solid fault inside the protected zone

The knee-point voltage  $V_K$  of the CT is chosen so that it is  $k$  times higher than the value of the voltage at the terminals of the CT when the current circulating in the relay is equal to  $I_{set}$ , where  $k$  is a value between 1.5 and 2.

Let

$$V_K \geq k (R_s + R_w + R_{ct}) I_{set}$$

where  $1.5 \leq k \leq 2$ .

To make matters clearer, the value of  $k$  shall be fixed at 2 for the rest of the calculation.

Thus:

$$V_K \geq 2 (R_s + R_w + R_{ct}) I_{set}$$

i.e.

$$V_K \geq 2 R_s I_{set}$$

since

$$R_w + R_{ct} \ll R_s.$$

If the stabilizing resistor is chosen such that  $R_s = (R_w + R_{ct}) \frac{I_{ssc}}{I_{set}}$ ,

the condition is

$$V_K \geq 2(R_w + R_{ct}) I_{ssc}$$

Choosing a knee-point voltage that satisfies this condition means that we can be sure that protection is activated for a fault current higher than  $I_{set}$ .

The knee-point voltage determined in this paragraph is the knee-point voltage  $V_K$  given in standard BS 3938 or the limit voltage  $V_S$  given in standard IEC 60044-1 (see section 6.1.3.7).

$$\text{Note: } V_S = \left( R_{ct} + \frac{P_n}{(I_{sn})^2} \right) K I_{sn}$$

#### **Limiting voltage peaks using a non-linear resistor**

When a short-circuit, with an approximate three-phase maximum  $I_{sc}$  value, occurs inside the protected zone, the CT is greatly saturated and very high voltage peaks occur (see CT saturation phenomenon at section 6.1.2).

Indeed, the CT dimensioning condition shows that the knee-point voltage can be reached for a fault current equal to  $2 I_{set}$ . If we again look at the example of the short-circuit current equal to  $100 I_{set}$ , *without saturation* of the CT we would have a voltage equal to 50 times the knee-point voltage  $V_K$ .

In fact, owing to the saturation, we can show (see Appendix C) that the peaks have an amplitude  $V_{peak}$  such that:

$$V_{peak} = 2 \sqrt{2 V_K (V_f - V_K)}$$

where  $V_f = (R_s + R_f + R_{ct}) I_{ssc}$ .

$V_f$ : voltage that would occur at the CT terminals if there was no saturation phenomenon

In our example:

$$V_f = 50 V_K$$

hence:

$$V_{peak} = 2 \sqrt{2 \times 49 V_K^2}.$$

For a CT knee-point voltage of 200 V, the voltage peak is 4,000 V.

These voltage peaks may damage the current transformer, the secondary circuit wiring and the differential protection, which are not dimensioned to receive such voltage levels. Non-linear resistors in parallel with the differential branch are therefore used in order to limit the voltage at the CT terminals to between 1 and 2 kV, which is the permissible voltage peak for low voltage equipment.

#### ***Thermal dimensioning of the stabilizing resistor***

This must be able to withstand:

- the protection current threshold on a permanent basis;
- the r.m.s. value of the maximum short-circuit current  $I_{rms}$  during the time delay of the back-up protection. It is shown that the expression  $I_{rms}$  for a saturated current transformer is (see Appendix C):

$$I_{rms} = 1.3(I_1)^{\frac{3}{4}}(I_{sc})^{\frac{1}{4}}$$

$I_1$  : r.m.s. current value at the limit of CT saturation,  $I_1 = \frac{V_K}{R_s + R_f + R_{ct}}$

$I_{sc}$  : r.m.s. value of the short-circuit current that would be obtained if there was no saturation

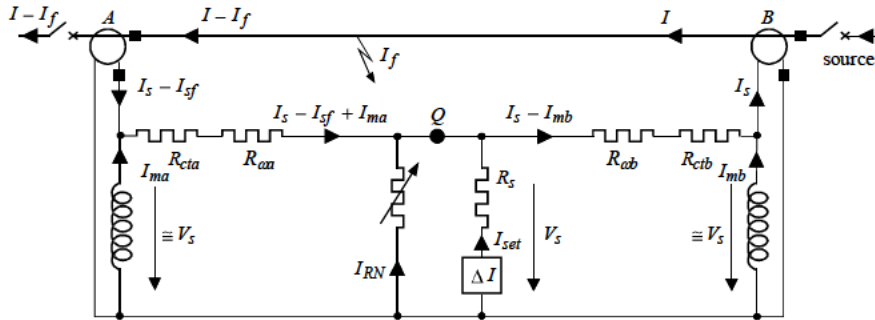
We may, for example, require the resistor to have a permissible short-time withstand current (1 second) higher than  $I_{rms}$ .

Note: this formula gives an accurate value for a highly saturated CT, i.e.  $I_{sc} \geq 3 I_1$ . In the case of a CT that is not very saturated, i.e.  $I_1 < I_{sc} < 3 I_1$ , the accurate calculation of the r.m.s. value (see Appendix C) shows us that this formula gives an excess error of between 30% for  $I_2 = I_1$  and 6% for  $I_2 = 3 I_1$  (see Table C-1).

#### ***Minimum fault current that can be detected***

We shall determine the minimum fault current that can be detected when the protection threshold setting is fixed at  $I_{set}$ .

The equivalent diagram in the event of an internal fault, taking into account the CT magnetizing currents and the non-linear resistor, is that shown in Figure 7-35.



- $I_f$  : fault current
- $I$  : current flowing through the protected zone
- $I_{ma}$  : A current transformer magnetizing current
- $I_{mb}$  : B current transformer magnetizing current
- $I_{RN}$  : current circulating in the non-linear resistor
- $I_{set}$  : protection setting threshold
- $I_s$  : current value  $I$  recalculated for the secondary of the CTs:  $I_s = \frac{I}{n}$
- $n$  : CT ratio
- $V_s$  : voltage at the terminals of the stabilizing resistor + relay  $\Delta I$
- $I_{sf}$  : fault current value  $I_f$  recalculated for the secondary of the CTs:  $I_{sf} = \frac{I_f}{n}$
- $R_{cta}, R_{ctb}$  : resistance of A and B current transformer windings
- $R_{wa}, R_{wb}$  : resistance of the wires linking the A and B current transformers to the differential branch

**Figure 7-35:** equivalent diagram taking into account the magnetizing currents and non-linear resistor

Let us assume that the fault current  $I_f$  causes a current  $I_{set}$  in the differential branch.

The voltage  $V_s$  created by the  $I_{set}$  current flowing through the stabilizing resistor imposes the voltage at the terminals of the non-linear resistor and at the terminals of the two CT magnetizing inductances.

This results in the three currents  $I_{ma}$ ,  $I_{mb}$ , and  $I_{RN}$  flowing in the same direction.

It is possible to check that the voltage at the terminals of the magnetizing inductances is close to  $V_s$  (voltage at the stabilizing resistor terminals).



Indeed, let us take for example the B end.

Thus:

$$(R_{ctb} + R_{wb})(I_s - I_{mb}) \cong (R_{ctb} + R_{wb}) I_s$$

since

$$I_{mb} \ll I_s .$$

Now, the choice of  $R_s$ , as we saw previously, is such that:

$$R_s I_{set} = (R_{wb} + R_{ctb}) I_{ssc} \text{ (assuming that } R_{wb} + R_{ctb} > R_{wa} + R_{cta} \text{)} .$$

$I_{ssc}$  : maximum short-circuit current

We may therefore say that  $(R_{ctb} + R_{wb}) I_s \ll V_s = R_s I_{set}$  since  $I_s \ll I_{ssc}$  (the current flowing through the protected zone is low compared with the maximum short-circuit current).

The voltage at the terminals of the magnetizing inductances is thus approximately equal to  $V_s$  .

The direction of each current is determined. Let us apply the first law of Kirchhoff to point Q. The sum of currents entering is equal to the sum of currents leaving.

$$I_s - I_{sd} + I_{ma} + I_{RN} + I_{set} = I_s - I_{mb}$$

hence:

$$I_{sd} = I_{ma} + I_{mb} + I_{RN} + I_{set}$$

Assuming that  $I_{ma}$  and  $I_{mb}$  are equal, which is the case if the two current transformers are equal, the minimum fault current  $I_f$  detectable is:

$$I_f = n (2I_m + I_{RN} + I_{set})$$

$I_m$  : CT magnetizing current

$n$  : CT ratio

The magnetizing current  $I_m$  to be taken into account is the magnetizing current of the CTs for a secondary voltage  $V_s = R_s I_{set}$  .

We saw previously that the knee-point voltage of the CTs was chosen such that  $V_K = 2R_s I_{set} = 2V_s$  (as long as  $k = 2$  is chosen).

The magnetizing current is thus the magnetizing current of the CTs when the secondary voltage is equal to half the knee-point voltage.

This value can be obtained using the magnetizing current curves given by CT manufacturers.

The order of magnitude of the magnetizing current for a voltage  $\frac{V_K}{2}$  is 1.5% of the CT nominal current, which is 75 mA for a 5 A CT and 15 mA for a 1 A CT.

The minimum protection setting threshold is 5% of the nominal current. The minimum fault current that can be detected is thus  $2 \times 1.5\% + 5\% = 8\%$  of the nominal current (with the non-linear resistor leakage current being neglected).

When differential protection is only used to detect phase-to-earth faults by connecting the CTs three phases so that the summation of the currents of each phase is affected (see Figure 7-31), the minimum fault current that can be detected is:

$$I_f = n (6 I_m + I_{RN} + I_{set})$$

Indeed, a magnetizing current circulates in the six current transformers.

Therefore, we may conclude that the magnetizing current limits protection sensitivity and CTs with a low magnetizing current must be chosen when protection sensitive to low fault currents is required.

#### 7.6.1.2. Application of high impedance differential protection

This is a question of determining the stabilizing resistance  $R_s$ , dimensioning the current transformers by calculating the minimum knee-point voltage required, and determining the minimum fault current that can be detected.

##### 7.6.1.2.1. Motor differential protection (ANSI code 87 M)

Motor differential protection can be used as long as the two terminals of each stator winding are accessible (see Figure 7-36).

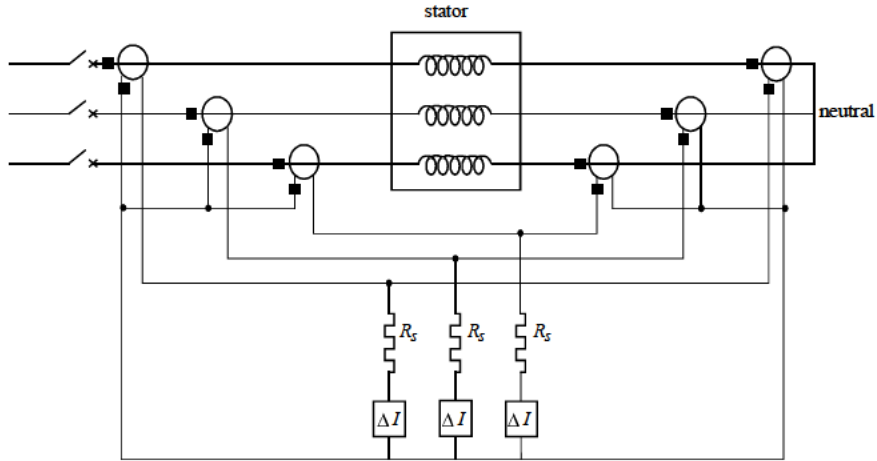


Figure 7-36: motor differential protection

The maximum current for which protection must remain stable is the start-up current  $I_{st}$ . This is approximately 5 to 7  $I_n$  if there is no start-up system limiting the current.

The condition to be met in order to avoid spurious tripping when the motor is started is:

$$R_s \geq (R_w + R_{ct}) \frac{I_{st}}{I_{set}}$$

Let us take for example  $R_s = \frac{R_w + R_{ct}}{I_{set}} I_{st}$  (\*)

(\*)  $R_s$  includes the relay resistance value

The condition to be met for current transformer dimensioning is:

$$V_K \geq 2 R_s I_{set} \text{ (if we take } k = 2 \text{)}$$

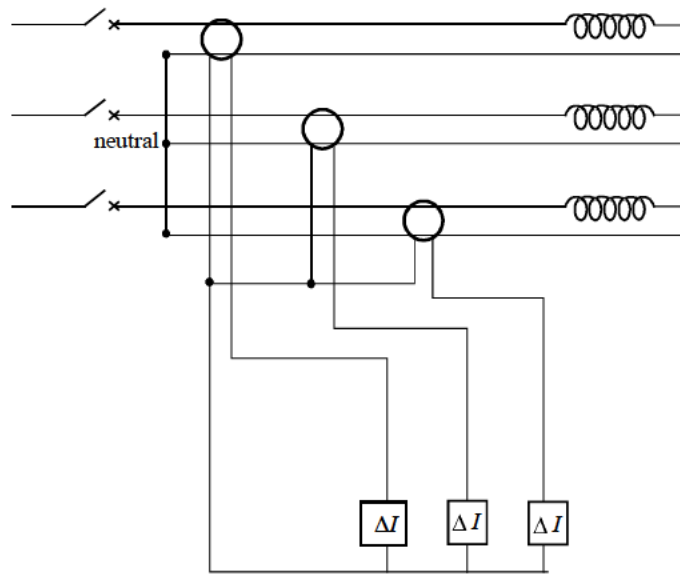
Thus:  $V_K \geq 2 (R_w + R_{ct}) I_{st}$

If  $I_{st} = 7 I_n$ , then  $V_K \geq 2 (R_w + R_{ct}) \times 7 I_n$ .

The minimum fault current that can be detected is:

$$I_f = n (2 I_m + I_{RN} + I_{set})$$

Note: it is possible to use a different assembly in which toroids surround the upstream and downstream links of each winding (see Figure 7-37).



**Figure 7-37:** motor differential protection with toroids surrounding the upstream and downstream links of each winding

This assembly does not require a stabilizing resistor as there is no risk of the CTs saturating when the motor is started up. Indeed, each CT measures the difference between the current of the winding upstream and downstream links and is therefore only sensitive to a fault current.

#### 7.6.1.2.2. Generator differential protection (ANSI code 87 G)

Generator differential protection can be used as long as the two terminals of each stator winding are accessible (see Figure 7-36).

The maximum current for which protection must remain stable is the generator short-circuit current (see section 4.1.2).

The protection operating time is almost instantaneous (it is not time-delayed), and the short-circuit current to be taken into account is therefore the current occurring during the subtransient period which is approximately 5 to 10  $I_n$  (see section 4.1.2).

The condition to be met to avoid spurious tripping upon occurrence of a short-circuit downstream of the generator occurs is:

$$R_s \geq (R_w + R_{ct}) \frac{I_{gsc}}{I_{set}}$$

$I_{gsc}$  : generator short-circuit current

Let us take for example 
$$R_s = \frac{R_w + R_{ct}}{I_{set}} I_{gsc} \quad (*)$$

(\*)  $R_s$  includes the value of the relay resistance

The condition to be met to avoid spurious tripping upon occurrence of a short-circuit downstream of the generator is:

$$V_K \geq 2 R_s I_{set} \text{ (if we take } k = 2 \text{)}$$

Thus: 
$$V_K \geq 2 (R_w + R_{ct}) I_{gsc}$$

If  $I_{gsc} = 10 I_n$ , then  $V_K \geq 2 (R_w + R_{ct}) \times 10 I_n$ .

The minimum fault current that can be detected is:

$$I_f = n (2 I_m + I_{RN} + I_{set})$$

#### 7.6.1.2.3. Busbar differential protection (ANSI code 87 B)

Busbars can be protected by considering that the protected zone does not only have two ends but a number  $q$  of ends that is generally above 2.

The differential protection will compare the sum of currents entering the busbar to the sum of currents leaving the busbar. If the two sums are equal the busbar is healthy, and if they are not, it is faulty.

Let us consider, for example, the diagram in Figure 7-38.

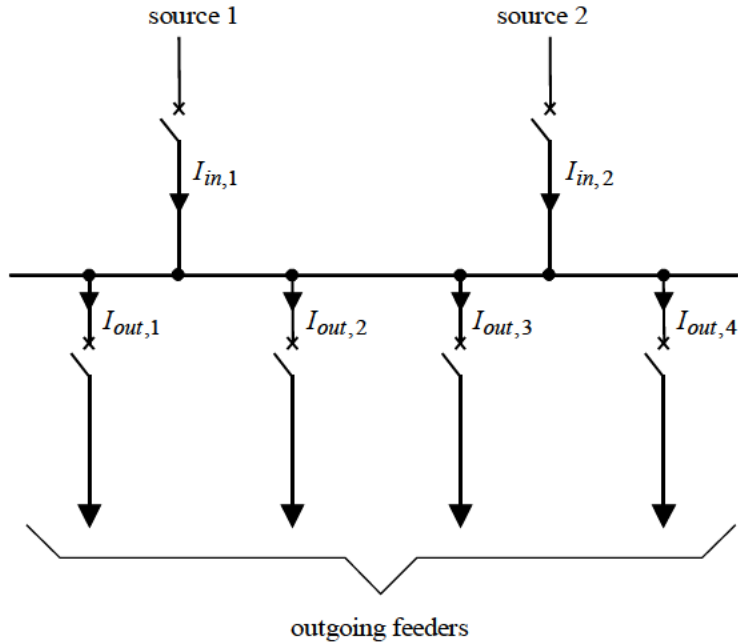


Figure 7-38: dual fed busbar with four outgoing feeders

We shall compare  $I_{in1} + I_{in2}$  with  $I_{out1} + I_{out2} + I_{out3} + I_{out4}$ .

To carry out this comparison, the current transformers of both sources and the four outgoing feeders are connected as shown in Figure 7-39.

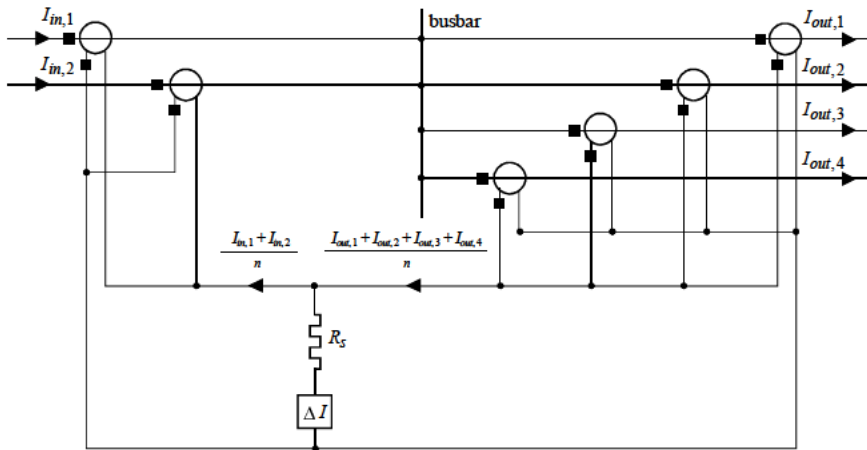


Figure 7-39: busbar differential protection assembly diagram

If protection against phase-to-phase and phase-to-earth faults is required, this assembly must be reproduced for each phase.

If phase-to-earth fault protection only is required, the summation of the currents of the three phases must be affected for each source and each feeder. The current sums of the three phases are then compared.

The maximum current for which protection must remain stable is the short-circuit current corresponding to the sum of the maximum short-circuit currents of each source.

The condition to be met to avoid spurious tripping upon occurrence of a short-circuit downstream of the busbar is:

$$R_s \geq (R_w + R_{ct}) \frac{I_{sc}}{I_{set}}$$

Let us take for example

$$R_s = \frac{R_w + R_{ct}}{I_r} I_{sc} \quad (*)$$

(\*)  $R_s$  includes the value of the relay resistance

The condition to be met for current transformer dimensioning is:

$$V_K \geq 2 R_s I_{set} \quad (\text{if we take } k = 2)$$

$$\text{Thus:} \quad V_K \geq 2 (R_w + R_{ct}) I_{sc}$$

The minimum fault current that can be detected is:

$$I_f = n (q I_m + I_{RN} + I_{set})$$

$q$ : number of current transformers connected to the differential branch, i.e. the sum of the number of sources and the number of feeders connected to the busbar, in Figure 7-38,  $q = 6$ .

We can observe that protection sensitivity is altered when a busbar to which a large number of feeders is connected must be protected.

Indeed,  $I_m$  is approximately 1.5% of  $I_n$  and the minimum protection setting threshold is 5% of  $I_n$ .

For  $q = 6$ , the minimum fault current that can be detected is:

$$I_f = (6 \times 1.5\% + 5\%) \times I_n = 14\% \text{ of } I_n$$

(with the non-linear resistor leakage current being neglected).

7.6.1.2.4. Restricted earth fault differential protection (ANSI codes 87 N or REF)

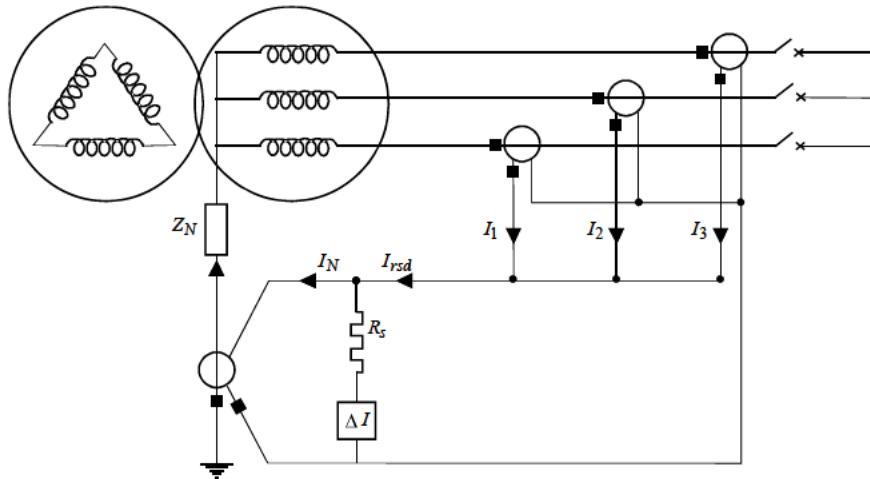
This is also abbreviated to REF (Restricted Earth Fault).

This is used to protect a transformer against earth faults.

Two different assemblies can be used depending on whether the transformer neutral is earthed or not.

**Directly or limiting impedance earthed transformer**

The assembly is shown in Figure 7-40.



**Figure 7-40:** restricted earth fault differential protection of a directly earthed or a limiting impedance earthed transformer

The residual current  $I_{rsd}$  is the sum of the currents of the three phases. It is equal to the earth fault current flowing through the CTs (see section 7.2, under the heading “Residual current measurement”).

If the earth fault is outside the transformer, the residual current is equal to the current that circulates in the earthing connection and there is no current in the differential branch.



If the fault is inside the transformer, the residual current flows in the opposite direction to the current circulating in the earthing connection. There is thus a current in the differential branch. In this case, the residual current, if there is one, is supplied by another transformer that is earthed (or an earthing transformer).

The maximum current for which protection must remain stable is the secondary three-phase short-circuit current.

The condition to be met to avoid spurious tripping upon occurrence of a short-circuit downstream of the transformer is:

$$R_s \geq (R_w + R_{ct}) \frac{I_{sc}}{I_{set}}$$

Let us take for example  $R_s = \frac{R_w + R_{ct}}{I_{set}} I_{sc}$  (\*)

(\*)  $R_s$  includes the value of the relay resistance

The condition to be met for current transformer dimensioning is:

$$V_K \geq 2 R_s I_{set} \quad (\text{if we take } k = 2)$$

Thus:  $V_K \geq 2 (R_w + R_{ct}) I_{sc}$

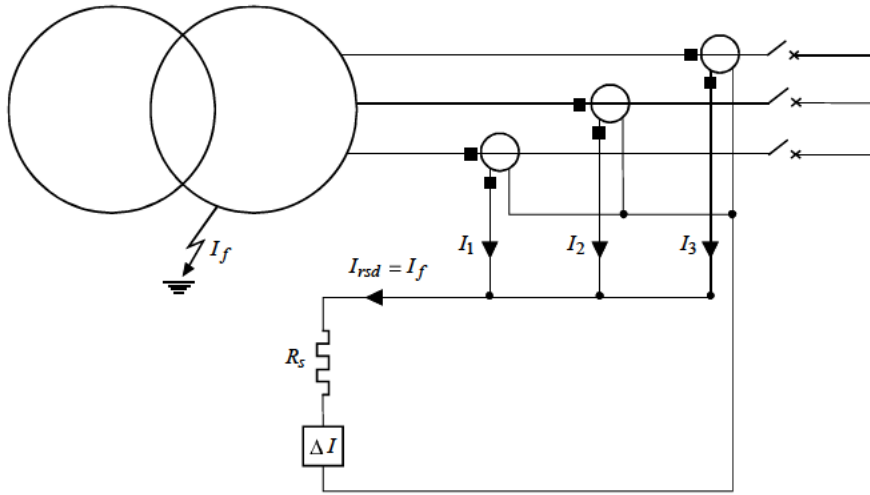
The minimum fault current that can be detected is:

$$I_f = n (4 I_m + I_{RN} + I_{set})$$

because there are four CTs connected to the differential branch and therefore four times the magnetizing current.

#### ***Transformer with unearthed neutral***

The assembly is shown in Figure 7-41.



**Figure 7-41:** restricted earth fault differential protection for an unearthed transformer

If the earth fault is outside the transformer, the residual current  $I_{rsd}$  is zero and no current circulates in the differential branch.

If the earth fault occurs inside the transformer, the residual current is equal to the fault current and there is thus a current in the differential branch.

Note: so that the fault current is not reduced to capacitive currents, there must be an earthing connection or an earthing transformer in the network.

The maximum current for which protection must remain stable is the secondary three-phase short-circuit current.

The condition to be met to avoid spurious tripping upon occurrence of a short-circuit downstream of the transformer is:

$$R_s \geq (R_w + R_{ct}) \frac{I_{sc}}{I_{set}}$$

Let us take for example

$$R_s = \frac{R_w + R_{ct}}{I_{set}} I_{sc} \quad (*)$$

(\*)  $R_s$  includes the value of the relay resistance

The condition to be met for current transformer dimensioning is:

$$V_K \geq 2 R_s I_{set} \quad (\text{if we take } k = 2).$$

Thus: 
$$V_K \geq 2 (R_w + R_{ct}) I_{sc}$$

The minimum fault current that can be detected is:

$$I_f = n (3 I_m + I_{RN} + I_{set})$$

because three CTs are connected to the differential branch and therefore there is three times the magnetizing current.

#### 7.6.1.3. Note about the application of high impedance differential protection

This type of differential protection cannot be used to protect long cables or lines.

Indeed, the current transformer knee-point voltage requirement is:

$$V_K \geq 2 (R_w + R_{ct}) I_{sc}$$

where:

$R_{ct}$  : resistance of current transformer windings.

$R_w$  : resistance of wires linking the current transformers from one end of the protected zone to the other. Indeed, if the cables were very long the relay would be located at one end or the other.

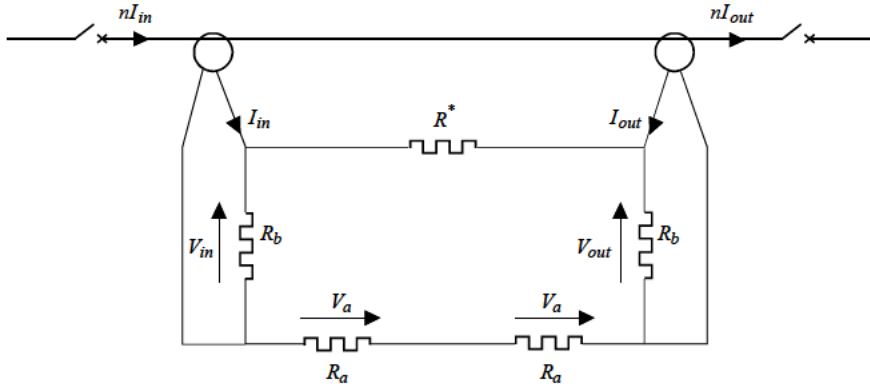
$R_w$  would therefore be high for a long cable length resulting in a very high knee-point voltage, which would mean using impossible current transformer dimensions.

The way to establish differential protection for long lines or cables is to have a low CT burden impedance regardless of the length of the cable. An example of this is differential protection using pilot wires, which is explained in section 7.6.2 below.

#### 7.6.2. Pilot wire differential protection for cables or lines (ANSI code 87 L)

This type of differential protection is biased for reasons that will be explained later on. It is activated when the differential current reaches a certain percentage of the through current.

*Principle (see Figure 7-42)*



$R_a$  : resistance of the protection relay

$R^*$  : resistance of the pilot wire (return trip)

**Figure 7-42:** block diagram of pilot wire differential protection

Resistors  $R_b$  carry out the current  $\rightarrow$  voltage conversion.

If we assume that the resistance of  $R_b$  is low compared with  $R^* + 2 R_a$ , we can say that  $V_{in} \cong R_b I_{in}$  and  $V_{out} \cong R_b I_{out}$ .

If  $V_a$  is the voltage at the terminals of the relay resistor, then:

$$V_a = (V_{in} - V_{out}) \frac{R_a}{2 R_a + R^*} \text{ (voltage divider formula)}$$

hence:

$$V_a = (I_{in} - I_{out}) \frac{R_b R_a}{2 R_a + R^*} .$$

We have thus produced the differential element  $I_{in} - I_{out}$ .

$V_m$  is proportional to the current  $I_m$ , by making the following ratio calculation  $\frac{V_a}{V_m} = \frac{I_{in} - I_{out}}{I_m} \left( \frac{R_a}{2R_a + R^*} \right)$ , we obtain an image of the percentage of differential current  $I_m - I_{out}$  in relation to the through current  $I_m$ .

This ratio is fulfilled by the protective relay.

When the power cable is off-load,  $I_m - I_{out} \cong 0$  and  $I_m \cong 0$ . the ratio  $\frac{I_m - I_{out}}{I_m}$  has an undetermined value and spurious tripping may occur. To overcome this problem, protection will only be activated if the input current is higher than the minimum load value  $I_0$ .

Protection will thus be activated when:

$$I_{in} - I_{out} > K I_{in} + I_0 \quad (\text{see Figure 7-43}).$$

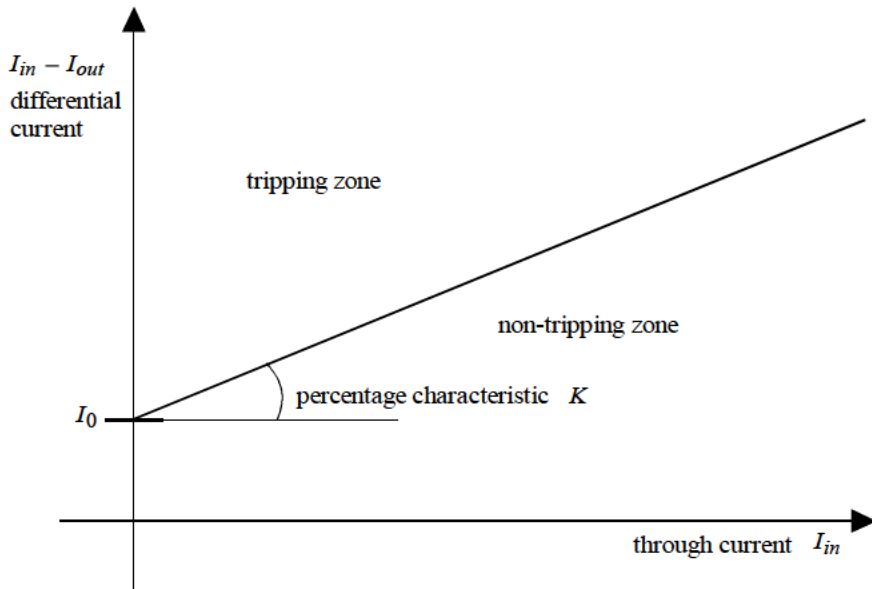


Figure 7-43: pilot wire differential protection tripping curve

Resistor  $R_b$  through which the through current  $I_m$  flows produces the voltage  $V_m$ , which is referred to as a “restraining element”.

Resistor  $R_a$  through which the current proportional to  $I_{in} - I_{out}$  flows produces the voltage  $V_a$ , which is referred to as an “operating element”.

We therefore arrive at the functional diagram shown in Figure 7-44.

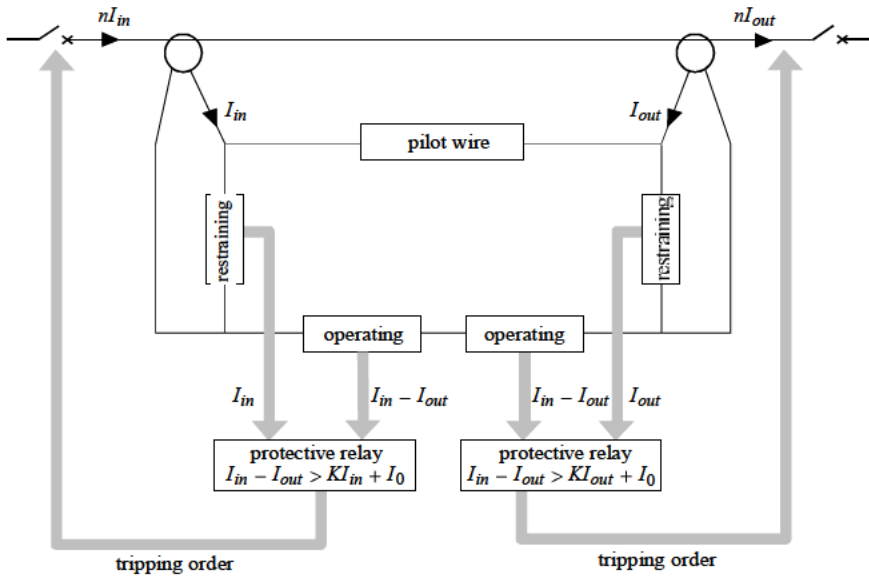


Figure 7-44: pilot wire differential protection functional diagram

Note: resistance  $R_b$  is low, as previously noted. It corresponds to the burden impedance detected by the current transformer, which is why this type of relay is often called a low impedance relay.

**Why must the biased principle be used?**

Let us consider a protection system fitted with 5 P 20 current transformers with a nominal secondary current of  $I_n = 1 A$ .

- The maximum error at  $I_n$  is  $\pm 1\%$  (see section 6.1.3.5).
- The maximum error at  $20 I_n$  is  $\pm 5\%$ .

Let us assume that we want to set the current threshold at 20% of  $I_n$ , i.e. 0.2A.

– If the protection is not biased then:

- for a fault current of  $20 I_n$  occurring outside the protected zone, the current measurement error may be:  $2 \times \frac{5}{100} \times 20 = 2 A$ . In other words, this is ten times as high as the setting threshold, which may therefore cause spurious tripping.

- If the protection is biased then:

- the current measurement error is at the most  $2 \times 5\% = 10\%$ , which is lower than the setting threshold at 20%. Spurious tripping is therefore unlikely to occur.

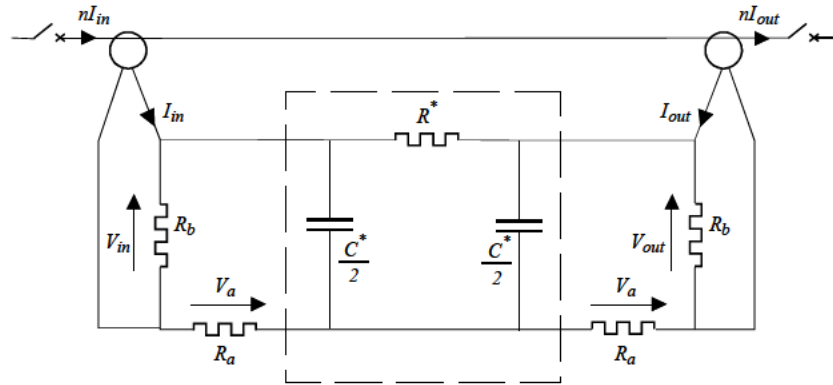
**Problem relating to pilot wire impedance**

If we take the measurement ratio  $\frac{V_a}{V_{in}} = \frac{I_{in} - I_{out}}{I_{in}} \left( \frac{R_a}{2R_a + R^*} \right)$  giving the

biased function, we can see that protection sensitivity will be altered by the  $R^*$  value of the pilot wire resistance. The longer the line, the lower the protection sensitivity will be.

Another serious problem exists because, with the pilot wire often being very long, the line capacitances distributed will generate currents that will create difficulties.

The pilot wire capacitances distributed can be represented by the diagram in Figure 7-45.



$C^*$  : pilot wire capacitance

**Figure 7-45:** distribution of pilot wire capacitances

**First difficulty**

In the event of an internal fault, in other words when  $V_{in} - V_{out} \neq 0$ , the currents that will circulate in the capacitances  $\frac{C^*}{2}$  will modify the voltage  $V_a$  at the terminals of the resistor  $R_a$ .

Thus:

$$\frac{V_a}{V_{in}} = \frac{I_{in} - I_{out}}{I_{in}} \times f(R^*, C^*, R_a)$$

showing that:

$$f(R^*, C^*, R_a) < \frac{R_a}{2R_a + R^*}.$$

The higher the capacitance  $C^*$ , the lower the protection sensitivity will be upon occurrence of an internal fault.

**Second difficulty**

In the absence of a fault,  $V_{in} = V_{out}$  and there is no current circulating in the pilot wire. However, owing to the line capacitance  $C^*$ , a current circulates in resistor  $R_a$ .

This current is equal to:

$$I_C = j \frac{C^*}{2} \omega V_e.$$

It is likely to cause spurious tripping.

The problem of pilot capacitive currents is very important and manufacturers have worked hard to overcome this difficulty by designing the assembly shown in Figure 7-46.



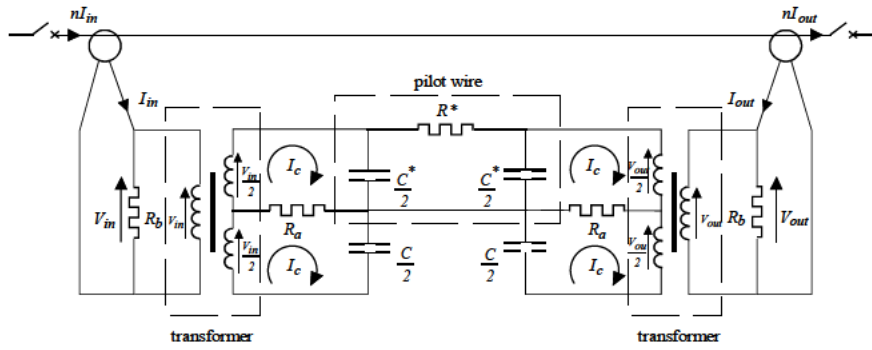


Figure 7-46: pilot wire capacitive current compensation

The voltage  $V_{in}$ , which is proportional to the input current, is applied to the primary of a transformer whose secondary has a middle point. The secondary winding is connected to the pilot wire and a compensating dipole made up of the capacitance  $\frac{C}{2}$  that generates a current in  $R_a$  in the opposite direction to the current generated by the pilot capacitance  $\frac{C^*}{2}$ .

In practice, compensation is not perfect and low current thus flows through the resistor  $R_a$ .

Nevertheless, it is generally sufficient to solve the problem of pilot capacitive currents.

**Problem relating to overvoltage**

Then an earth fault occurs in a substation, a rise in the potential of the exposed conductive parts occurs owing to the passage of the fault current in the substation earth resistance. Since the exposed conductive parts of all the equipment are connected to the same earth, the rise in potential of all the parts does not create any local problems. However, the pilot link transmits this potential to the other end of the protected line, to a piece of equipment whose exposed conductive part is at the earth potential. The differential protective relay at one end may thus be submitted to high voltages applied between the pilot wire connection and the exposed conductive part. This is why isolating transformers are generally inserted on the pilot wires to allow the relay to withstand the voltage up to levels of approximately 15 kV.

For the capacitive current compensation to continue to work, it is necessary to attack the compensating dipole across an isolating transformer that is entirely identical to the previous one.

This gives us the diagram in Figure 7-47.

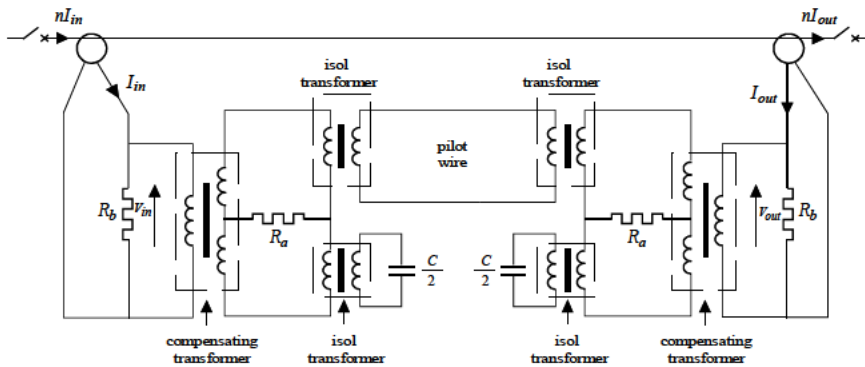


Figure 7-47: overvoltage withstand using isolating transformers

**Problem relating to the induced voltage on the pilot wire**

When a phase-to-earth fault occurs outside the protected zone with a high fault current  $I_f$ , the mutual impedance between the power cable and the pilot wire will induce a voltage (see section 5.7) that will generate a parasitic current in  $R_a$  that might cause spurious tripping.

It is impossible to discriminate between this parasitic current and the current circulating in the pilot wire in the event of an internal fault.

One way of solving this problem is to twist the two pilot wires, thus greatly reducing the induced voltage. Indeed, when the wires are crossed, the induced voltage is in the opposite direction.

If this does not work sufficiently, the pilot wire must be moved away from the power cable, which, from an economic point of view, is rarely possible since the cost of an extra trench would be too much.

**Problem related to monitoring the pilot wire**

The pilot wire is a vital part of the differential protection because it is this line which carries the information from one end of the cable to be protected to the other.

This pilot wire is a fairly vulnerable part of the protection, especially in urban supply networks where numerous roadworks may damage it. For this type of differential protection to be reliable, it is important to fit it with a monitoring device that is able to detect all kinds of pilot wire faults (cut, short-circuit, etc.) wherever they are located.

To avoid the risk of spurious tripping when damage to the pilot wire occurs, the monitoring device must lock the protection.

The differential protection therefore must be time delayed for a period equal to the transmission and locking order processing time.

If this is not the case, damage to the pilot wire may activate the protection, which may jeopardize service continuity.

### ***Other solutions to the transmission of information problem***

#### *First solution*

This consists of transmitting the information via currents with frequencies other than 50 Hz (or 60 Hz), in other words, by transmitting a coded message on the pilot wire using carrier frequencies between 400 and 2,400 Hz, for example.

This solution immediately provides the following advantages:

- with the carrier currents having very different frequencies from the current at 50 Hz, overcoming the problem of induced voltages in the pilot wire in the event of a fault on the power line outside the protected zone is very easy using a filtering technique;
- the coding of information allows the current measurement information to be transmitted regardless of the  $R^*$  and  $C^*$  pilot wire specifications. This results in accurate protection, which is not sensitive to the length of the link;
- monitoring the state of the pilot wire is easy and the differential protection does not need to be time delayed. Indeed, the current equality information is supplied by a coded message. When damage to the pilot wire occurs, the information is absent but does not cause the protection to be activated.

#### *Second solution*

This consists of transmitting the information numerically via optical fiber links. This solution provides the same advantages as the previous solution.

However, it is more costly as it requires an analog-digital conversion and a converter allowing the electrical signal to be converted to a “light” wave.

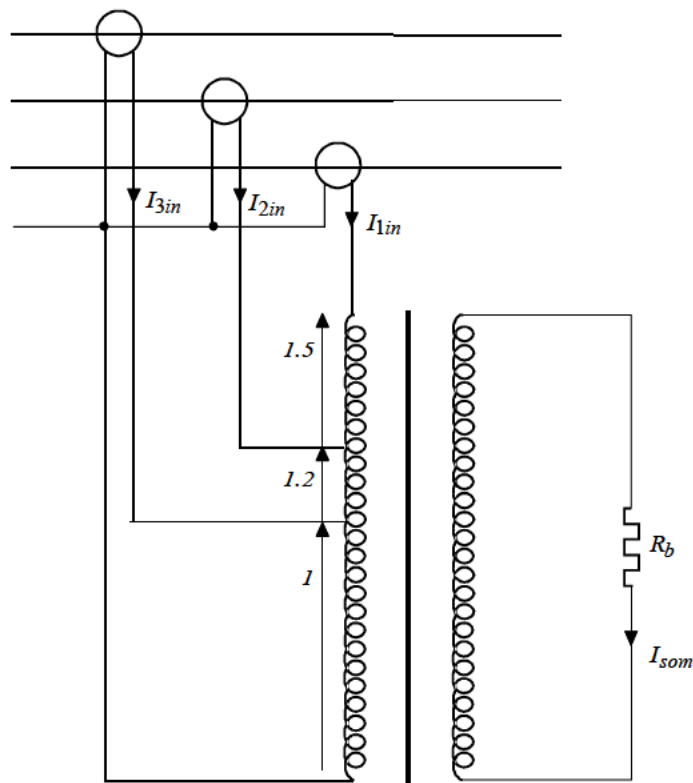
**Method to establish economical three-phase protection**

To simplify and reduce the cost of a three-phase link protection, a summing transformer that produces the weighted sum of the CT currents of the three phases is used.

This protection works well against all types of fault as long as the earthing system is direct or via a limiting impedance (with a high enough limiting current).

This summing transformer is able to supply a single-phase secondary current whatever the type of fault.

It produces the sum:  $I_{sum} = 1.5 I_1 + 1.2 I_2 + I_3$  using the assembly in Figure 7-48.



**Figure 7-48:** summing transformer used to establish economical three-phase protection

Thus:

$$I_{sum,in} = 1.5 I_{1in} + 1.2 I_{2in} + I_{3in} \quad \text{weighted sum of the currents of the three phases entering the protecting zone}$$

$$I_{sum,out} = 1.5 I_{1out} + 1.2 I_{2out} + I_{3out} \quad \text{weighted sum of the currents of the three phases leaving the protected zone}$$

The protection will carry out a percentage comparison:

$$\frac{\Delta I}{I} (\%) = \frac{I_{sum,in} - I_{sum,out}}{I_{sum,in}} .$$

When the fault occurs outside the protected zone  $I_{sum,in} = I_{sum,out}$  and  $\frac{\Delta I}{I} (\%) = 0$ .

When a fault occurs inside the protected zone, whether it is single-phase, two-phase or three-phase  $I_{sum,in} \neq I_{sum,out}$  and  $\frac{\Delta I}{I} (\%) \neq 0$ .

This process allows a single-phase type protection to be used and thus considerable savings to be made.

The weighting coefficients applied 1, 1.2 and 1.5 can in theory be of any value. In practice, these are the coefficients that give the best sensitivity threshold for all types of single-phase, two-phase and three-phase faults.

The protection tripping threshold is set at 0.56.

The protection is thus activated if  $\frac{I_{sum,in} - I_{sum,out}}{I_{sum,in}} \geq 0.56 + \frac{I_0}{I_{sum,in}}$ .

$I_0$ : minimum load value (see principle in this section)

Complex number calculations allow the protection sensitivity for each type of fault to be calculated without difficulty. For example, by neglecting  $I_0$ , a phase-to-earth fault on phase 1 will activate protection if the fault current is higher than 16% of the through current, in other words  $\frac{\Delta I_1}{I_1} > 16\%$ .

The protection sensitivity is 20% for phase 2 and 24% for phase 3.

This three-phase type protection, which requires a relatively low investment, therefore constitutes an interesting solution for three-phase cable protection.

Note: manufacturers do not provide the protection operating curve. They only supply the protection sensitivity and guarantee that it will work for higher short-circuit current values.

### 7.6.3. Transformer differential protection (ANSI code 87 T)

Transformer differential protection protects against short-circuits between turns of a winding and between windings that correspond to phase-to-phase or three-phase type short-circuits.

If there is no earthing connection at the transformer location point, this protection can also be used to protect against earth faults. If the earth fault current is limited by an impedance, it is generally not possible to set the current threshold to a value less than the limiting current. The protection must be then carried out by a high impedance differential protection.

Transformer differential protection operates very quickly, roughly 30 ms, which allows any transformer deterioration in the event of a short-circuit between windings to be avoided.

Transformers cannot be differentially protected using high impedance differential protection for phase-to-phase short-circuit due to the natural differential currents that occur:

- the transformer inrush currents. The operating speed required means that a time delay longer than the duration of this current cannot be used (several tenths of a second);
- the action of the on-load tap changer causes a differential current.

The characteristics of transformer differential protection are related to the transformer specifications:

- transformation ratio between the current entering  $I_{in}$  and the current leaving  $I_{out}$ ;
- primary and secondary coupling method;
- inrush current;
- permanent magnetizing current.

The block diagram is shown in Figure 7-49.

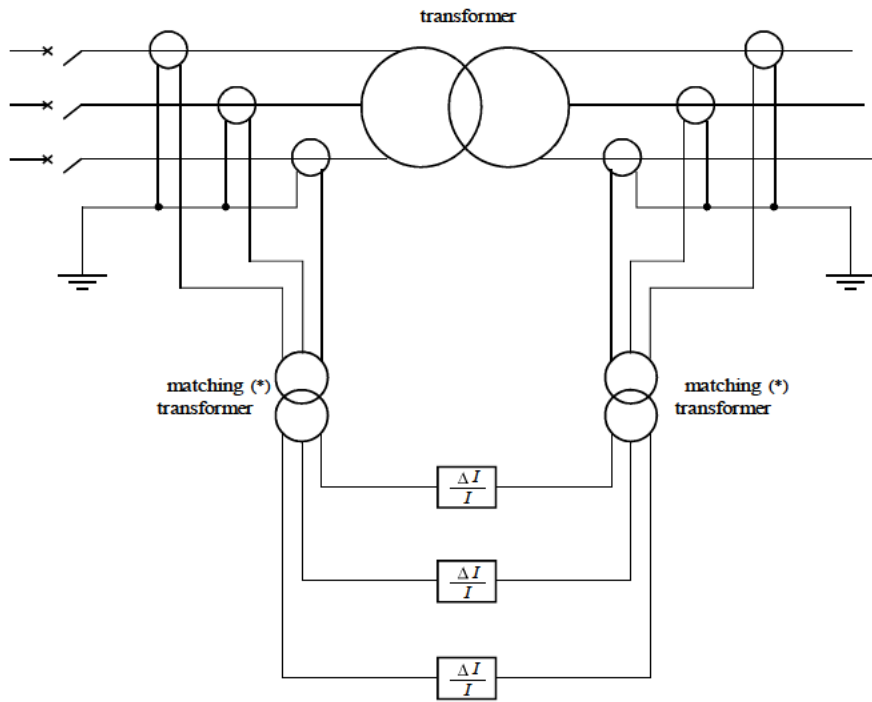


Figure 7-49: transformer differential protection block diagram

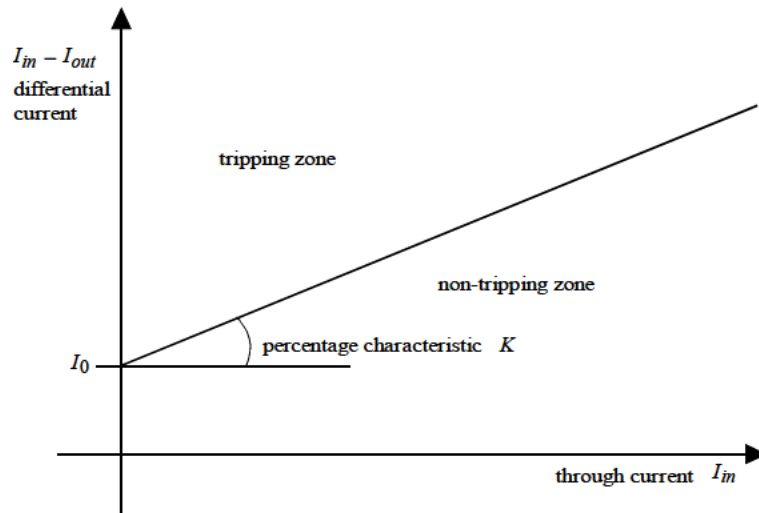


Figure 7-50: transformer differential protection tripping curve

In order to prevent tripping upon occurrence of high fault currents of external origin, biased differential protection devices are used. This is because of:

- the differential current due to the on-load tap changer;
- the current transformer measurement errors, as for pilot wire differential protection for cables or lines (see section 7.6.2).

Protection is activated when  $I_{in} - I_{out} > K I_{in} + I_o$  (see Figure 7-50).

***Problem relating to the transformation ratio and the coupling method***

The primary and secondary currents have different amplitudes owing to the transformation ratio and different phases depending on the coupling method (delta-star transformer makes a phase displacement of 30°). Therefore, the current values measured must be readjusted so that the signals compared are equal during normal operation. This is done using matching auxiliary transformers whose role is to balance the amplitudes and phases.

When one side of the transformer is star-connected with an earthed neutral, the matching transformers located on this side are delta-connected, so that the residual currents that would be detected upon occurrence of an earth fault outside the transformer are cleared.

***Problem relating to the transformer inrush current***

Transformer switching causes a very high transient current (from 8 to 15  $I_n$ ), which only flows through the primary winding and lasts several tenths of a second (see section 10.3.1). It is thus detected by the protection as a differential current and it lasts far longer than the protection operating time (30 ms). Detection based only on the difference between the transformer primary and secondary currents would cause the protection to be activated. Therefore, the protection must be able to distinguish between a differential current due to a fault and a differential inrush current.

Experience has shown that the inrush current wave contains at least 20% of second harmonic components (current at a frequency of 100 Hz), while this percentage is never higher than 5% upon occurrence of an overcurrent due to a fault inside the transformer.

The protection must therefore simply be locked when the percentage of second harmonic component in relation to the fundamental harmonic component (current at 50 Hz) is higher than 15%, i.e.  $\frac{I_2}{I_1} > 15\%$ .



***Problem relating to the magnetizing current upon occurrence of an overvoltage of external origin***

The magnetizing current constitutes a difference between the transformer primary and secondary currents (see section 6.1.1). It is therefore detected as a fault current by the differential protection even though it is not due to a fault. In normal operating conditions, this magnetizing current is very low and does not reach the protection operating threshold.

However, when an overvoltage occurs outside the transformer, the magnetic material saturates (in general the transformers are dimensioned to be able to operate at saturation limit for the nominal supply voltage), and the magnetizing current value greatly increases (see section 6.1.2). The protection operating threshold can therefore be reached.

Experience has shown that the magnetizing current due to the magnetic saturation has a high rate of fifth harmonic components (current at a frequency of 250 Hz).

To prevent spurious tripping upon occurrence of an overvoltage of external origin, there are two solutions:

- detect a rise in voltage that locks the protection;
- detect saturation using the presence of fifth harmonic current that locks the protection.

Transformer differential protection therefore requires fairly complex functions as it must be able to measure second and fifth harmonic currents or, in order to avoid measuring fifth harmonic currents, it must be able to detect overvoltages of external origin.

**7.7. Thermal overload protection (ANSI code 49)**

This is used to protect against machine overloads (motor, generator, transformer, etc.). It simulates the heat rise of the machine to be protected using the current measurement.

***Principle***

The protection determines the machine heat rise  $H$  using a thermal model defined by the following differential equation:

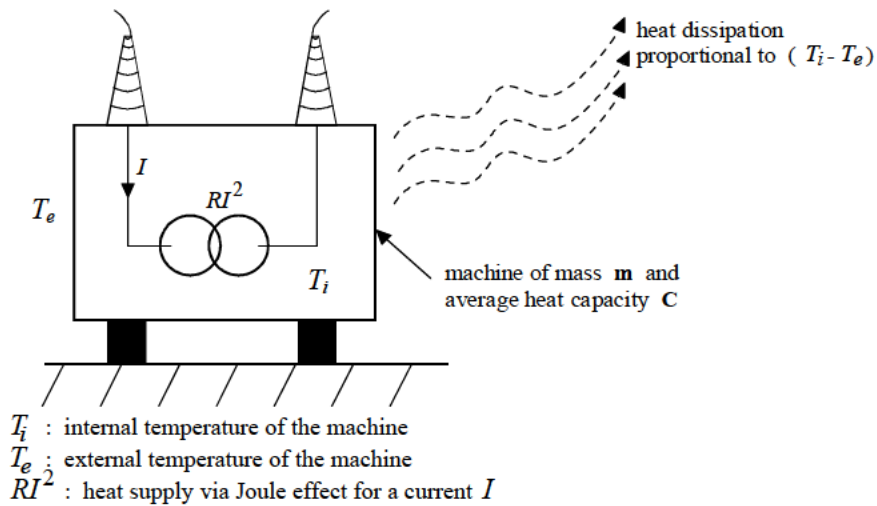
$$\tau \frac{dH}{dt} + H = \left( \frac{I}{I_n} \right)^2$$

where:

- $H$  : heat rise
- $\tau$  : machine thermal time constant
- $I_n$  : nominal current
- $I$  : r.m.s. current

We shall trace the origin of this equation and use it for two specific cases: heat rise of a machine from a cold state, and overload of a machine from a hot state.

The thermal equilibrium equation must be calculated for a time  $dt$  (see Figure 7-51).



**Figure 7-51: machine thermal equilibrium**

The heat supply via the Joule effect  $RI^2 dt$  is equal to the sum of:

- the machine heat dissipation through convection with the external environment. This dissipation is proportional to the temperature difference inside and outside the machine. Let us take  $\theta = T_i - T_e$ . The heat dissipation is equal to  $K \theta dt$  where  $K$  is the characteristic constant of the heat exchange;

– the quantity of heat stored by the machine due to a rise in its temperature, i.e.  $m C d\theta$ , where  $m$  is the machine mass and  $C$  is the average heat capacity of the machine. This gives the following equation:

$$RI^2 dt = K\theta dt + mC d\theta$$

By dividing by  $dt$ , we obtain a differential equation, as follows:

$$mC \frac{d\theta}{dt} + K\theta = RI^2 \quad (1)$$

We shall now show how to determine the machine heat rise using this thermal equilibrium equation, assuming that the r.m.s. current  $I$  is constant.

Let us define the machine heat rise  $H$  such that:

$$H = \frac{\theta}{\theta_n}$$

$\theta_n$ : difference between the machine temperature and the outside environment, when the machine is operating at its nominal current for a period long enough for its temperature to be stabilized.

For example, if  $H = 120\%$ , the machine overheats by 20% in relation to its nominal operation.

Let us look again at equation (1). When  $I = I_n$  and the temperature is stable, then  $\frac{d\theta}{dt} = 0$

thus:

$$\theta_n = \frac{R}{K} I_n^2$$

We can therefore rewrite (1) by dividing by  $\theta_n$ , thus:

$$mC \frac{dH}{dt} + KH = K \frac{I^2}{I_n^2}$$

$$\text{or} \quad \frac{mC}{K} \frac{dH}{dt} + H = \left( \frac{I}{I_n} \right)^2 \quad (2)$$

The aim of thermal overload protection is to determine the heating level  $H$  of the machine using this equation.

***Machine heat rise from a cold state***

When a machine is cold, its heat rise is  $H = 0$  because it has the same temperature as its surroundings.

Let us assume that the machine is loaded with a constant current  $I_l$ . We shall determine its heat rise in relation to time.

Differential equation (2) becomes:

$$\frac{mC}{K} \frac{dH}{dt} + H = \left( \frac{I_l}{I_n} \right)^2$$

By solving this equation with  $H = 0$  as the initial condition, we find:

$$H = \left( \frac{I_l}{I_n} \right)^2 \left( 1 - e^{-\frac{K}{mC} t} \right)$$

If we take:  $\tau = \frac{mC}{K}$

then: 
$$H = \left( \frac{I_l}{I_n} \right)^2 \left( 1 - e^{-\frac{t}{\tau}} \right)$$

$\tau$ . represents the thermal time constant of the machine

The heat rise  $H$  develops according to the curve in Figure 7-52.

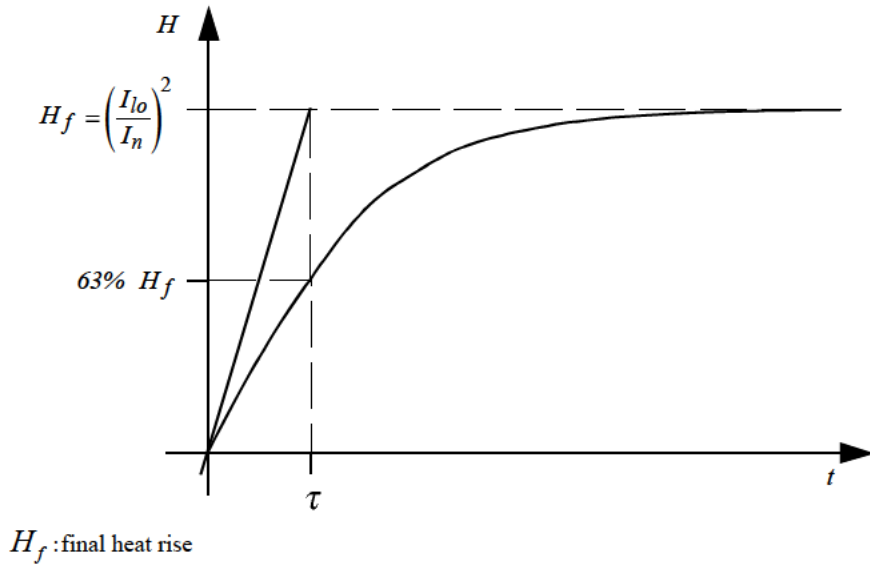


Figure 7-52: loading a machine from a cold state

After time  $\tau$  corresponding to the time constant, the machine heat rise reaches 63% of its final rise value.

The thermal time constant of the machine is given by the manufacturers, or it is estimated or measured by the user.

Thermal overload protection determines how the heat rise develops using knowledge of the time constant  $\tau$  and load current.

If a setting threshold  $H_{set}$  is fixed, the protection activation time  $t_a$  can be calculated:

$$H_{set} = \left(\frac{I_l}{I_n}\right)^2 \left(1 - e^{-\frac{t_a}{\tau}}\right)$$

$$e^{-\frac{t_a}{\tau}} = 1 - H_{set} \left(\frac{I_n}{I_l}\right)^2$$

$$t_a = \tau \operatorname{Ln} \left( \frac{1}{1 - H_{set} \left( \frac{I_l}{I_n} \right)^2} \right)$$

$\operatorname{Ln}$  : Naperian logarithm

Note: thermal overload protection cannot be used against excessive motor start-up time. Indeed, the motor start-up current is very high and its heat rise is approximately proportional to the square of the current, which means that it is very rapid. During start-up, the heat supply is not totally diffused in the motor and the local temperature at the location point of the windings and insulating material can be excessive.

Thermal overload protection considers the overall heat capacity of the motor and an instantaneous heat diffusion and does not therefore take into account local heat rises. The result is that the thermal overload protection determines the heat rise caused by the start-up, but cannot protect a motor against excessive start-up time and rotor locking (see section 7.9). Therefore, it is particularly effective for protecting against slow overloads.

*Example*

Let us take the example of a transformer with a thermal time constant  $\tau = 45 \text{ min}$ . From a cold state, the transformer is loaded with a current  $I_l$  higher than 30% of the nominal current  $\frac{I_l}{I_n} = 1.3$ .

A heat rise of  $H_{set} = 115\%$  is authorized in the transformer.

Let us calculate the protection activation time:

$$t_a = 45 \operatorname{Ln} \left( \frac{1}{1 - \frac{115}{(1.3)^2}} \right)$$

$$t_a = 51 \text{ min}$$

***Machine overload from a hot state***

Let us suppose that the protected machine has been operating at its nominal current  $I_n$  for a long enough time for its temperature to be stable.

By definition, at the initial state, the heat rise  $H = 100\%$ .

The machine undergoes a constant current overload  $I_{ol}$  and we shall determine its heat rise in relation to time.

Differential equation (2) becomes:

$$\frac{mC}{K} \frac{dH}{dt} + H = \left(\frac{I_{ol}}{I_n}\right)^2$$

By solving this equation with  $H = 1$  as the initial condition, we find:

$$H = \left(\frac{I_s}{I_n}\right)^2 - \left(\left(\frac{I_s}{I_n}\right)^2 - 1\right) e^{-\frac{K}{mC}t}$$

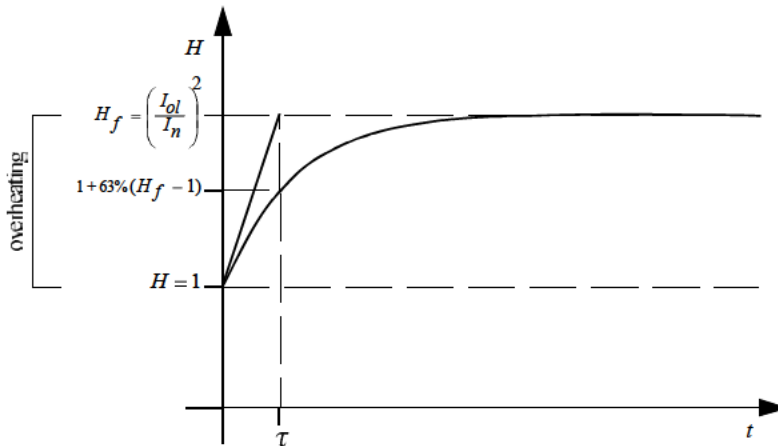
If we take:  $\tau = \frac{mC}{K}$

Then:

$$H = \left(\frac{I_f}{I_n}\right)^2 - \left(\left(\frac{I_f}{I_n}\right)^2 - 1\right) e^{-\frac{t}{\tau}}$$

$\tau$  represents the thermal time constant of the machine.

The heat rise  $H$  develops according to the curve in Figure 7-53.



$H_f$  : final heat rise

$H_f - 1$  : overheating

Figure 7-53: development of the heat rise  $H$  upon overloading of the machine

After a time  $\tau$  corresponding to the time constant, the machine reaches 63% of its final overheating level, i.e. the heat rise of the machine if it had to withstand overheating for an infinite period of time (long enough for its temperature to stabilize).

The thermal time constant of the machine is given by the manufacturers, or estimated or measured by the user.

Thermal overload protection determines the development of the heat rise using knowledge of the time constant  $\tau$  and the overload current  $I_{ol}$ .

If we fix a setting threshold  $H_{set}$ , the protection activation time  $t_a$  can be calculated:

$$H_{set} = \left(\frac{I_{ol}}{I_n}\right)^2 - \left(\left(\frac{I_{ol}}{I_n}\right)^2 - 1\right) e^{-\frac{t_a}{\tau}}$$

$$e^{-\frac{t_a}{\tau}} = \frac{\left(\frac{I_{ol}}{I_n}\right)^2 - H_{set}}{\left(\frac{I_{ol}}{I_n}\right)^2 - 1}$$

$$t_a = \tau \operatorname{Ln} \left[ \frac{\left(\frac{I_{ol}}{I_n}\right)^2 - 1}{\left(\frac{I_{ol}}{I_n}\right)^2 - H_{set}} \right]$$

$\operatorname{Ln}$  : Naperian logarithm

#### Example 1

Let us take a transformer with a thermal time constant of  $\tau = 45$  min.

From an initial heated state,  $H = 100\%$ , it undergoes a constant current overload 30% above the nominal current:

$$\frac{I_{ol}}{I_n} = 1.3$$



A heat rise of  $H_{set} = 115\%$  is authorized in the transformer.

Let us calculate the protection activation time:

$$t_a = 45 \operatorname{Ln} \left( \frac{(1.3)^2 - 1}{(1.3)^2 - 1.15} \right)$$

$$t_a = 11 \text{ min}$$

### Example 2

Let us take a transformer with a thermal time constant of  $\tau = 35$  min.

A heat rise of  $H_{set} = 120\%$  in the transformer is authorized.

What is the overload that the machine can withstand for 15 minutes without the protection being activated?

For  $t_a = 15$  min, then:

$$1.2 = \left( \frac{I_{ol}}{I_n} \right)^2 - \left( \left( \frac{I_{ol}}{I_n} \right)^2 - 1 \right) e^{-\frac{15}{35}}$$

$$\left( \frac{I_{ol}}{I_n} \right)^2 = \frac{e^{-\frac{15}{35}} - 1.2}{e^{-\frac{15}{35}} - 1}$$

$$\frac{I_{ol}}{I_n} = 1.25$$

The transformer can accept a maximum overload of 25% for 15 min without the protection being activated.

### ***Specific properties of some thermal overload protective relays (example of the Sepam 2000)***

#### *Influence of the negative sequence component*

To determine the heat rise of rotating machines, the relay takes into account the negative-sequence component. Indeed, the rotating field corresponding to the negative-sequence component induces a double frequency rotor current, which

causes considerable losses. This is why the Schneider Sepam 2000 thermal overload protection takes into account an equivalent current:

$$I_{eq}^2 = I^2 + KI_i^2$$

$I$  : maximum value of the three phase currents

$I_i$  : negative-sequence component of the current

$K$  : negative-sequence component factor corresponding to a weighting coefficient

The coefficient value  $K$  is chosen from four values: 0 – 2.25 – 45 – 9.

For an asynchronous motor, the choice is made in the following manner:

– Calculate

$$k = 2 \times \frac{T_{st}}{T_n} \times \frac{1}{sl \left( \frac{I_{st}}{I_n} \right)^2} - 1.$$

$T_n, T_{st}$  : nominal torque and start-up torque

$I_n, I_{st}$  : nominal current and start-up current

$sl$  : slip

– Choose the value of  $K$  closest to  $k$ .

#### *Time constant during cooling (motor stopped)*

For a motor, cooling takes place more efficiently when the motor is operating rather than when it is stopped because of the ventilation caused by the rotation.

To take this phenomenon into account, the thermal time constant of the protection can take two values:

- $\tau_1$  time constant during the heat rise (motor operating);
- $\tau_2$  time constant during cooling (motor stopped).

### **7.8. Negative phase unbalance protection (ANSI code 46)**

This is used to protect a rotating machine (motor or generator) against current unbalances.

This unbalance may come from:

- the power source (transformer or generator), which does not supply a symmetrical three-phase voltage (for a motor, 1% of  $V_i$  causes 7% of  $I_i$ );

- other consumers who do not constitute a symmetrical load causing the power supply network to have a voltage unbalance;
- from a two-phase power supply following a blown fuse or a phase being cut;
- from an inversion of phases due to a connection error;
- from the motor start-up.

In a machine, the rotating field corresponding to the negative sequence component induces a double frequency rotor current, which causes considerable Joule losses.

Negative phase unbalance protection makes it possible to prevent an excessive heat rise of the machine due to unbalance.

### **Principle**

The protection determines the negative-sequence current  $I_{(2)}$  with the following calculation:

$$I_{(2)} = \frac{1}{3} (I_1 + a^2 I_2 + a I_3)$$

where  $a = e^{j \frac{2\pi}{3}}$ .

Indeed, if we assume that the current is the sum of the positive-sequence current system  $I_{1(1)}$ ,  $I_{2(1)}$ ,  $I_{3(1)}$  and negative-sequence current system  $I_{1(2)}$ ,  $I_{2(2)}$ ,  $I_{3(2)}$  (see section 4.2.2), the currents in each phase are:

$$I_1 = I_{1(1)} + I_{1(2)}$$

$$I_2 = I_{2(1)} + I_{2(2)}$$

$$I_3 = I_{3(1)} + I_{3(2)}$$

By definition, the following applies for the positive sequence system:

$$I_{2(1)} = a^2 I_{1(1)} \text{ and } I_{3(1)} = a I_{1(1)} \text{ (see Figure 7-54)}$$

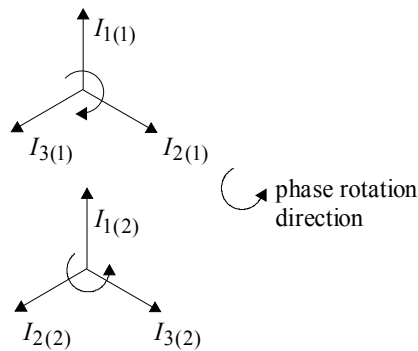
where  $a = e^{j \frac{2\pi}{3}}$  : rotation operator of  $\frac{2\pi}{3}$

$$I_{1(1)} + a^2 I_{2(1)} + a I_{3(1)} = 0$$

for the negative sequence system:

$$I_{2(2)} = a I_{1(2)} \text{ and } I_{3(2)} = a^2 I_{1(2)} \text{ (see Figure 7-54)}$$

$$I_{1(2)} + a I_{2(2)} + a^2 I_{3(2)} = 0$$



**Figure 7-54:** positive- and negative-sequence three-phase systems

Let us carry out the following calculation:

$$\begin{aligned} I_1 + a^2 I_2 + a I_3 &= I_{1(1)} + I_{1(2)} + a^2 I_{2(1)} + a^2 I_{2(2)} + a I_{3(1)} + a I_{3(2)} \\ &= \underbrace{I_{1(1)} + a^2 I_{2(1)} + a I_{3(1)}}_{= 0} + I_{1(2)} + a^2 a I_{1(2)} + a a^2 I_{1(2)} \\ &= 3 I_{1(2)} \quad \text{since } a^3 = 1 \end{aligned}$$

Thus: 
$$I_{(2)} = \frac{1}{3} (I_1 + a^2 I_2 + a I_3)$$

If the protection is only connected to the current sensors of two phases, the negative-sequence component is determined using the following calculation:

$$I_{(2)} = \frac{1}{\sqrt{3}} (I_1 - a^2 I_3).$$

$$\begin{aligned} \text{Indeed: } I_1 - a^2 I_3 &= I_{1(1)} + I_{1(2)} - a^2 I_{3(1)} - a^2 I_{3(2)} \\ &= I_{1(1)} + I_{1(2)} - a^2 a I_{1(1)} - a^2 a^2 I_{1(2)} \\ &= I_{1(2)}(1 - a) \text{ since } a^3 = 1 \\ &= \sqrt{3} I_{1(2)} \text{ since } |1 - a| = \sqrt{3} \end{aligned}$$

Note: the formula above is only valid if the zero sequence component is zero, i.e. in the absence of an earth fault. If this is not the case:  $(I_1 - a^2 I_3) = I_{(2)}(1 - a) + I_0(1 - a^2)$ .  $I_0$ : zero-sequence component. Measurement is then not correct. However, it is not a problem if the protection is untimely activated upon an earth fault in a machine.

#### ***Setting indication for motors***

During the start-up time, the motor absorbs a negative-sequence current component of 20 to 30% of the nominal current. To prevent spurious tripping during start-up, and in order to have satisfactory settings, double threshold independent time protection or inverse time protection is used.

#### ***Double threshold independent time protection***

Low threshold:  $I_{(2)} = 0.2 I_n$ , time delay = start-up time + several seconds.

High threshold:  $I_{(2)} = 0.4 I_n$ , time delay = 0.5 seconds.

Using the high threshold, the cutting of a phase causing a major unbalance can be prevented. Switching must therefore be rapid so as not to damage the motor.

#### ***Inverse time protection***

In order to prevent spurious tripping during start-up, the protection operating curve must be situated above the following co-ordinate point:

$$I_{(2)} = 0.3 I_n$$

$$T = T_{st} \quad (\text{start-up time})$$

#### ***Setting indication for generators***

Generally, inverse time protection with a negative-sequence component current setting threshold fixed at 15% of  $I_n$  is used.

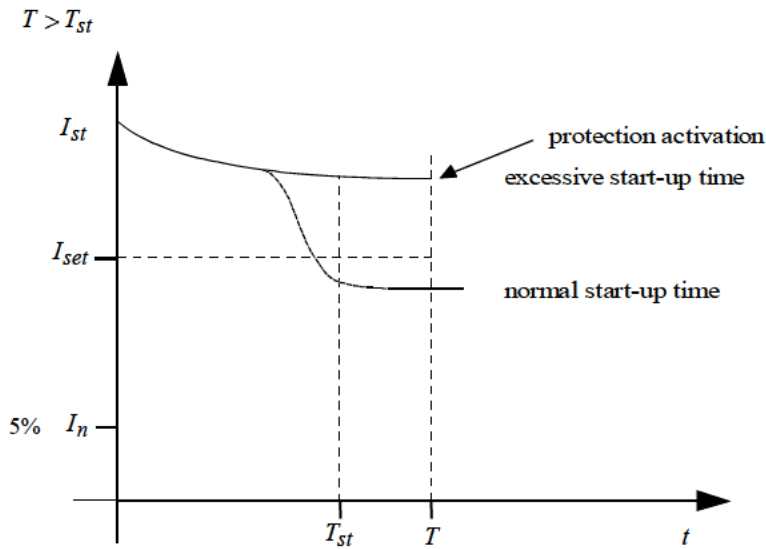
The protection activation time must be several seconds at the setting threshold.

**7.9. Excessive start-up time and locked rotor protection (ANSI code 51 LR)**

The principle is based on independent time overcurrent protection.

*Excessive start-up time*

When a machine is switched on, protection is activated if the current of one of the three phases is higher than the current threshold  $I_{set}$  for a time  $T$  (see Figure 7-55). This time  $T$  must be above the maximum value of the normal start-up time  $T_{st}$ .



$I_{st}$  : start-up current of the motor with its associated start-up system (auto-transformer, star-delta, rotor resistance, electronic starter, etc.), if there is one

**Figure 7-55:** *excessive start-up time*

The origin of start-up can be detected in one of the following two ways:

- using the information that the switching device is closed;
- when the current rises above a low threshold (for example, 5% of  $I_n$ ).

*Setting indications*

- the current setting threshold  $I_{set}$  is approximately  $\frac{I_{st}}{2}$  and must be higher than  $1.3 I_n$ ;

– the time delay  $T$  must be longer than the start-up time by several seconds for the lowest supply voltage.

Note: some relays have a threshold fixed at  $2.5 I_n$  or  $4 I_n$ . These thresholds are too high for motors fed by a start-up system limiting the current (e.g. an electronic starter).

**Rotor locking**

The protection is locked during start-up.

In steady-state operating conditions, the protection is activated when the current of one of the three phases is higher than the current threshold  $I_{set}$  for a time exceeding the time delay  $T_{br}$ .

Figure 7-56 shows an example of rotor locking over a time exceeding the time delay.

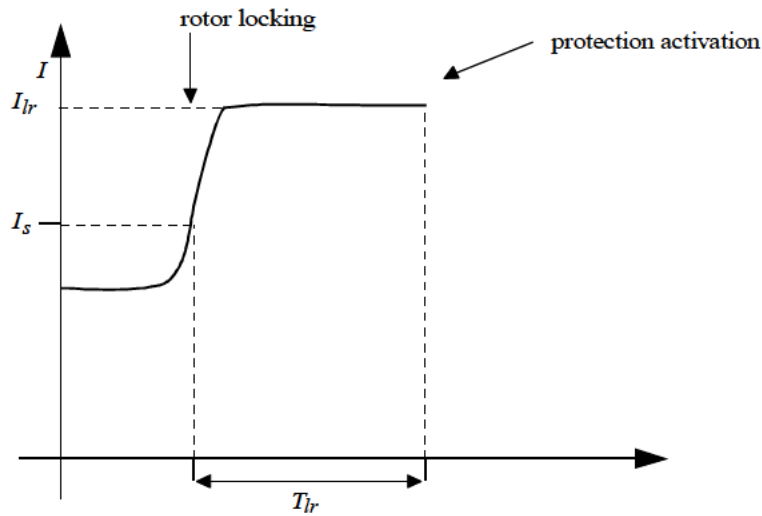


Figure 7-56: rotor locking

The locked rotor current  $I_{lr}$  is equal to the start-up current of the motor without the start-up system. Indeed, the system is short-circuited after start-up.

*Setting indications*

In most multifunctional relays, the threshold  $I_s$  of the excessive start-up and rotor locking functions is the same. Therefore, the two thresholds are identical.

$I_{set}$  is approximately  $\frac{I_{st}}{2}$  and must be higher than  $1.3 I_n$ .

The time delay  $T_{lr}$  is between 0.5 and 1 second.

Note 1: protection against excessive start-up time and rotor locking can be ensured by monitoring the motor speed.

Note 2: to determine the time delay  $T_{lr}$ , the motor reacceleration time after a drop in voltage must be taken into account. Indeed, protection must not be activated due to an overcurrent caused by a voltage drop.

**7.10. Protection against too many successive start-ups (ANSI code 66)**

Too many successive start-ups may be due to:

- the faulty operation of an automatic control device;
- too many manual operations;
- a series of reclosings when a fault occurs.

The consequences are:

- excessive rise in temperature;
- a succession of mechanical shocks on the couplings.

These problems can be avoided using a protection device that counts the number of start-ups carried out over a determined period of time.

***Principle***

During operating conditions in which the current is zero (motor inoperative), the protection counts a start-up every time the current rises above the setting threshold (for example, 5% of  $I_n$ ).

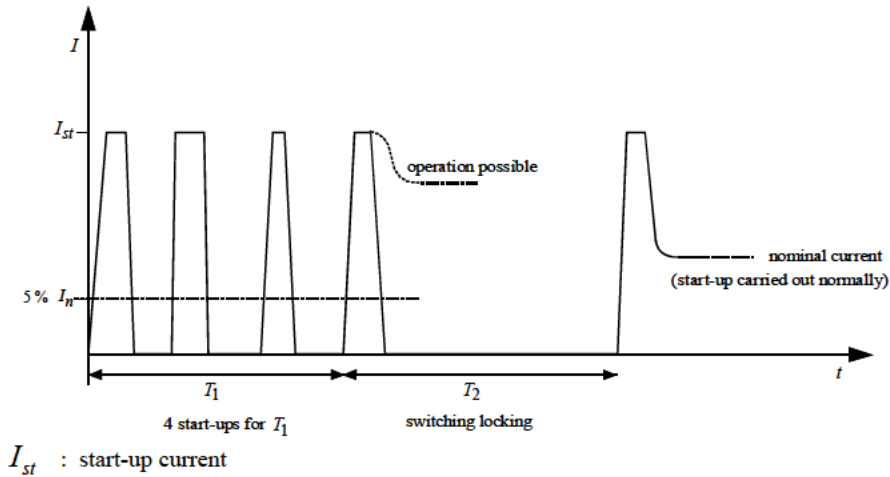
The counter is reset at zero at the end of a period  $T_1$ .  $T_1$  is the time interval for which the start-ups are considered to be successive.

When the counter exceeds a fixed value, the protection prevents a new start-up for a time  $T_2$ .



**Example (see Figure 7-57)**

The number of successive start-ups is limited to 4.  
 The motor is considered to be started at a threshold of 5% of  $I_n$ .



**Figure 7-57:** a successive number of start-ups above the limiting value

**Specific features of the Schneider Sepam 2000**

- The Sepam offers the possibility of limiting the number of starts per hour, as well as limiting the number of successive starts.
- It offers the possibility of limiting the number of hot starts. A hot start corresponds, for example, to the first thermal overload protection threshold being exceeded (see section 7.7). Operation is the same as for a cold start with a lower number of authorized starts.

**Setting indications**

The maximum amount of starts is generally given by the motor manufacturer. It does not only depend on the motor but on the load, the start-up system, and the short-circuit power at the motor connection point (voltage drop upon start-up).

**7.11. Phase undercurrent protection (ANSI code 37)**

This protection is used to protect pump unpriming or breaks in load coupling.

The unpriming of a suction pump can be due to the absence of liquid in the pump.

Pump unpriming or a break in a coupling leads to off-load operation of the motor and therefore a drop in the current absorbed.

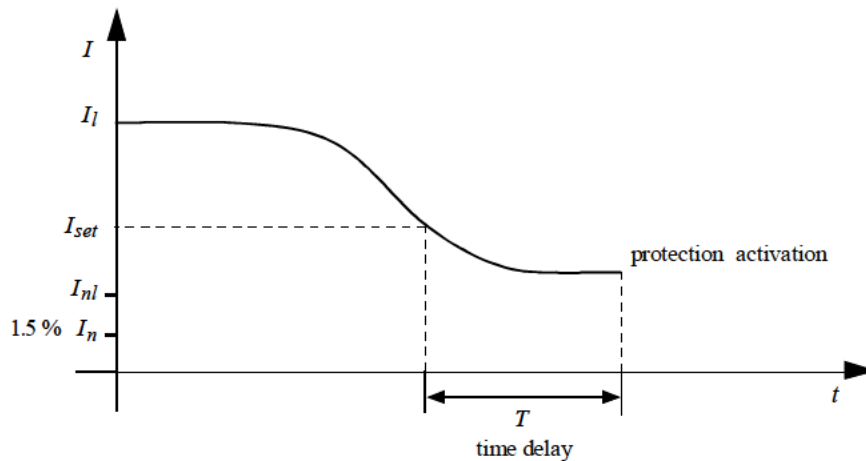
Off-load operation of the motor can be detected using undercurrent protection.

**Principle**

The protection is activated when the current is lower than a threshold  $I_{set}$ . It is inactive when the motor is not operating, i.e. when the current is zero, for example, lower than 1.5%.

It includes a definite time delay.

The protection threshold is set between the motor off-load current and the minimum current normally absorbed (see Figure 7-58).



$I_l$  : minimum current normally absorbed by the load  
 $I_{nl}$  : no-load current

**Figure 7-58:** no-load motor operation

**Setting indications**

- no-load current < current threshold  $I_{set}$  < minimum current normally absorbed;
- the time delay setting is approximately 1 second.

### 7.12. Undervoltage protection (ANSI code 27)

Voltage drops can be due to:

- a network overload;
- the faulty operation of a transformer tap changer;
- a short-circuit.

The consequences are an increase in motor Joule losses:

- when switched on, the start torque and the maximum torque are proportional to the square of the voltage. A drop in voltage will lead to a longer start time and thus to considerable Joule losses, or, if the resistive torque is higher than the maximum torque, the rotor will stop;
- during normal operation, the active power absorbed by the motor is  $P_a = \sqrt{3} U I \cos \varphi$ . If the voltage drops, the current increases so that the motor power is maintained (the  $\cos \varphi$  will not vary much). For slight variations in voltage, then  $P_a = \sqrt{3} U I \cos \varphi = \text{constant}$ . The Joule losses equal to  $3 R I^2$  will thus increase.

The undervoltage protection will give the order for the motors to be tripped before they are damaged.

This type of protection can also be used:

- to monitor the operation of voltage regulators;
- to load shed the non-priority consumer network when an overload occurs;
- to monitor the voltage before sources are switched over.

#### **Principle**

The protection is activated when one of the voltages is lower than the threshold  $U_{set}$ . It includes a definite time delay.

#### **Setting indications**

*Example for motor protection*

Voltage setting threshold from 0.75 to 0.8  $U_n$ .

The time delay setting will be a compromise between:

- the motor possibilities;
- the load shedding program;
- the protection scheme (the time delay required may be long).

### 7.13. Remanent undervoltage protection (ANSI code 27)

After the opening of a circuit during an automatic switchover (or a short cut in the power supplied by the utility), the motors maintain a voltage for the time it takes for the flux to be extinguished. If the voltage supply is restored while the motors are operating as generators, this may lead to phase opposition coupling causing transient electrical and mechanical phenomena that might be damaging for the motor.

The remanent undervoltage protection monitors the voltage of the busbar supplying the motors and authorizes the power supply to be restored if this voltage is lower than the threshold.

#### **Principle**

The protection is activated if the voltage is lower than the threshold  $U_{set}$ . It includes a definite time delay.

It operates according to the same principle as the undervoltage protection (see section 7.12), but with a lower setting threshold.

#### **Setting threshold**

- voltage setting threshold from 20 to 25% of  $U_n$ ;
- 0.1 second time delay.

### 7.14. Positive sequence undervoltage and phase rotation direction protection (ANSI code 27 D - 47)

This type of protection is used to protect motors. It performs two protection functions:

– *protects against positive-sequence voltage drops.* The positive-sequence voltage accurately defines the motor torque value. It is therefore more accurate than the voltage measurement. The consequences of a drop in positive-sequence voltage are those indicated in section 7.12 (undervoltage protection);

– *protects against an inversion in phase rotation direction.* An inverse phase rotation direction may be due to a cable connection error. This inversion leads to the motors operating in the opposite direction, which may be prejudicial to the mechanical load and, consequently, to the motor.

**Method of determining positive sequence voltage value**

The protection determines the positive-sequence component of the three-phase voltage system by carrying out the following calculation:

$$V_{(1)} = \frac{1}{3} (V_1 + aV_2 + a^2V_3) \text{ where } a = e^{j\frac{2\pi}{3}}$$

This calculation allows the negative-sequence voltage component to be cleared.

If we assume that the voltage is the sum of a positive-sequence voltage system  $V_{1(1)}, V_{2(1)}, V_{3(1)}$  and a negative-sequence voltage system  $V_{1(2)}, V_{2(2)}, V_{3(2)}$  (it is assumed that there is no zero-sequence component).

The voltage of each phase is:

$$V_1 = V_{1(1)} + V_{1(2)}$$

$$V_2 = V_{2(1)} + V_{2(2)}$$

$$V_3 = V_{3(1)} + V_{3(2)}$$

For a positive-sequence system we have by definition:

$$V_{2(1)} = a^2V_{1(1)} \text{ and } V_{3(1)} = aV_{1(1)}$$

$$V_{1(1)} + a^2V_{2(1)} + aV_{3(1)} = 0$$

and for the negative-sequence system:

$$V_{2(2)} = aV_{1(2)} \text{ and } V_{3(2)} = a^2V_{1(2)}$$

$$V_{1(2)} + aV_{2(2)} + a^2V_{3(2)} = 0$$

Let us carry out the following calculation:

$$\begin{aligned} V_1 + aV_2 + a^2V_3 &= V_{1(1)} + V_{1(2)} + aV_{2(1)} + aV_{2(2)} + a^2V_{3(1)} + a^2V_{3(2)} \\ &= V_{1(1)} + \underbrace{aa^2V_{1(1)} + a^2aV_{1(1)} + V_{1(2)} + aV_{2(2)} + a^2V_{3(2)}}_{=0} \\ &= 3V_{1(1)} \text{ since } a^3 = 1 \end{aligned}$$

thus:

$$V_{1(1)} = \frac{1}{3} (V_1 + aV_2 + a^2V_3)$$

If the voltage sensors are linked between phases, the following calculation is carried out:

$$\begin{aligned}
 U_{21}-a^2U_{32} &= V_1-V_2-a^2V_2+a^2V_3 \\
 &= V_1+V_2(-1-a^2)+a^2V_3 \\
 &= V_1+aV_2+a^2V_3 \text{ since } 1+a+a^2=0 \\
 &= 3V_{1(1)}
 \end{aligned}$$

**Setting indications***Against a drop in positive-sequence voltage*

Voltage setting threshold from 0.75 to 0.8  $V_n$ .

The time delay setting will be a compromise between:

- the motor possibilities;
- the load shedding scheme;
- the protection scheme (the time delay required may be long).

*Against an inversion in phase rotation direction*

For the Schneider Sepam 2000, there is no setting and the protection decides that the phase rotation direction is inverse when both of the following conditions apply:

- the positive sequence voltage calculated is lower than 10% of  $V_n$ ;
- the voltage measured is higher than 80% of  $V_n$ .

**7.15. Overvoltage protection (ANSI code 59)**

This protection is used to protect equipment against an abnormally high voltage.

It can also be used:

- to check the presence of enough voltage to carry out a power supply transfer with, in this case, a threshold lower than  $U_n$ ;
- to monitor the operation of voltage regulators.

**Principle**

The protection is activated when one of the phase-to-phase voltages is higher than the setting threshold  $U_{set}$ .

Generally, it includes a definite time delay.

**Setting indications**

- For use against overvoltages,  $U_{set}$  can be set at 1.1  $U_n$  with a time delay of approximately 1 second.

– To check the presence of enough voltage,  $U_{set}$  can be set at  $0.95 U_n$  with a time delay of approximately 3 seconds to make sure that the voltage is stable before the power supply is switched over.

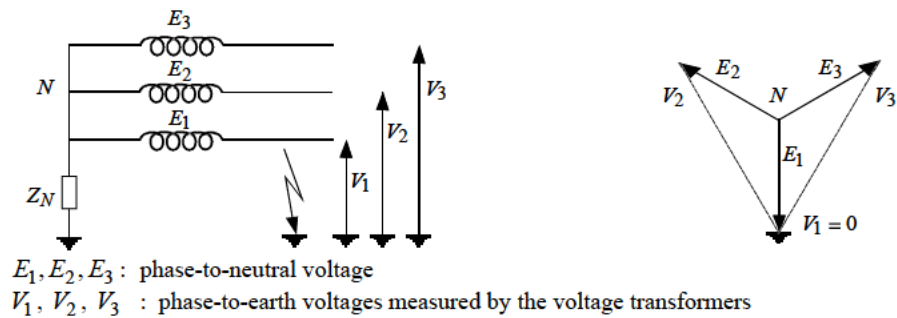
**7.16. Residual overvoltage protection (ANSI code 59 N)**

This protection is used to detect phase-to-earth faults. It notably allows the detection of the first fault in an unearthed neutral system.

**Principle**

The protection monitors the rise in neutral potential in relation to earth, which is the characteristic phenomenon of a phase-to-earth fault in the network.

Let us assume there is a solid phase-to-earth fault (zero fault impedance) on phase 1 (see Figure 7-59).



**Figure 7-59:** solid phase-to-earth fault in an unearthed or limiting impedance earthed system

When a phase-to-earth fault occurs on phase 1, the neutral potential in relation to earth  $V_{neut}$  takes the value  $-E_1$ :

$$V_{neut} = -E_1$$

$$|V_{neut}| = |E_1|$$

where  $|E_1|$  is the amplitude of the single-phase voltage

*Accessible neutral point*

A single-phase voltage transformer installed between the neutral point of the transformer and earth will allow the neutral potential to be measured directly.

*Non-accessible neutral point*

When the neutral point is not accessible, or in order to avoid installing a single-phase voltage transformer, the protection determines the neutral potential via the three voltage transformers connected between phase and earth by carrying out the following calculation:

$$V_{rsd} = V_1 + V_2 + V_3 \quad V_{rsd} \text{ is referred to as the residual voltage}$$

Indeed, upon occurrence of a phase-to-earth fault on phase 1:

$$V_1 = 0 \quad V_2 = E_2 - E_1 \quad \text{and} \quad V_3 = E_3 - E_1 \quad (\text{see Figure 7-59})$$

hence:

$$\begin{aligned} V_1 + V_2 + V_3 &= 0 + E_2 - E_1 + E_3 - E_1 \\ &= E_1 + E_2 + E_3 - 3E_1 \\ &= -3E_1 \text{ since } E_1 + E_2 + E_3 = 0 \end{aligned}$$

thus:

$$V_{rsd} = 3V_{neut}$$

The residual voltage is therefore equal to three times the neutral potential in relation to earth.

Note: the residual voltage measurement can also be carried out via a voltage transformer with three windings whose tertiary is connected in an open delta arrangement (see Figure 7-15).

**Setting indications**

Measurement via single-phase voltage transformer: threshold set at 10% of  $V_n$ .

Residual voltage measurement: threshold set at 30% of  $V_n$  (10% of  $3V_n$ ).

The time delay depends on the selectivity with the other network protection devices.

**7.17. Under or overfrequency protection (ANSI code 81)**

Variations in the power supply frequency may be due to:

- overloads when the network is fed by a limited power source (internal generation plant operating while cut off from the utility network);
- faulty operation of a generator frequency regulator;
- cutting off of a generation plant from an interconnected network;



- power supply being cut off in an installation fitted with large motors. The motors then feed the installation the time it takes for the flux to be extinguished with a decreasing frequency.

The consequences are:

- the faulty operation of synchronous loads (recorders, clocks, etc.);
- an increase in eddy current losses of the machines, these being proportional to the square of the frequency;
- a variation in motor speed that may lead to the load being damaged.

Under or overfrequency protection will allow:

- loads to be shed by cutting off the power to non-priority consumers in the event of an overload;
- the network to be cut up into several sub-networks in order to overcome problems relating to the stability of the machines. When this is the case, it is preferable to cut off the power supply to the motors;
  - micro-plants not fitted with synchronous control to be cut off;
  - the power supply to a plant fitted with large asynchronous motors to be cut off upon occurrence of a network micro-cut.

### ***Principle***

The protection compares the network frequency to a minimum or maximum threshold frequency. The protection is deactivated if the phase-to-phase voltage is lower than a predetermined threshold (for example 35% of  $U_n$ ). Generally, it includes a definite time delay.

### ***Setting indications***

- For internal generation: threshold set at  $\pm 2$  Hz of the nominal frequency.
- For an interconnected network: threshold set at  $\pm 0.5$  Hz of the nominal frequency.
- Time delay of several seconds.

## **7.18. Protection against reversals in reactive power (ANSI code 32 Q)**

This protection is used to detect a loss in excitation of the synchronous machines connected to the network.

Excitation of the synchronous machines is carried out by a direct current flowing through the rotor called the inductor and it is controlled by an excitation regulator.

The loss in excitation of a synchronous machine is due to a fault in the rotor circuit (cut, short-circuit, etc.).

Upon occurrence of a loss in excitation, the machine compensates for the drop in magnetizing power by absorbing the reactive power on the network. The reactive power of the machine is thus negative. The protection detects the inversion of the sign of the machine's reactive power.

The loss in excitation of a generator previously connected to the network causes its resynchronization with the network. It then operates asynchronously at a slightly higher speed. This results in a temperature rise in the stator because the reactive current can be high, and a temperature rise in the rotor which is not dimensioned for induced currents.

The loss in excitation of a synchronous motor will lead to a break in its synchronism resulting in it operating asynchronously. A high induced current will circulate in the rotor and cause it to heat up.

### ***Principle***

The protection determines the reactive power  $Q$  of the machine and compares it to a threshold  $-|Q_{set}|$ . It is activated if  $Q < -|Q_{set}|$ .

It includes a constant time delay.

### ***Setting indications***

The reactive power threshold may be set at 30% of the apparent power  $|Q_{set}| = 0.3S_n$ .

The time delay may be set at several seconds.

## **7.19. Protection against reversals in active power (ANSI code 32 P)**

This type of protection allows an inversion of the active power sign to be detected in the absence of an electrical fault.

It is particularly used for:

- preventing an internal generation plant from supplying the utility with power;
- protecting a motor, which is cut off from its power supply, against generator operation when it is driven by its load;

– protecting a generator from working as a motor, which may damage the driving machine.

***Protection against reversals in active power from internal generation***

Reversals in active power can be due to a cut in the utility power supply or a high-speed or time-delayed automatic reclosing at the utility substation.

When this happens, the internal generation plant feeds the other utility customers.

Some of the consequences are:

- an overload in the internal generation plant;
- faulty selectivity if a fault occurs after the inversion of the active power sign.

The protection determines the active power  $P$  on the main busbar of the consumer substation and compares it to a threshold  $-|P_{set}|$ .

It is activated if  $P < -|P_{set}|$ .

It includes a definite time delay.

***Setting indications***

$$P_{set} = 1 \text{ to } 2\% \text{ of } \sqrt{3} I_{nCT} U_{nVT}$$

$I_{nCT}$ : current transformer rating

$U_{nVT}$ : voltage transformer rating

with a zero time delay.

***Protection against generator operation of asynchronous motors***

When there is a cut in the voltage supply, the synchronous motors, driven by the inertia of the load, operate as generators. They then feed the network for as long as it takes for the flux to be extinguished.

When a short cut occurs, e.g. during a high-speed or time-delayed automatic reclosing, it is important to disconnect the motors from the network so that the motors are re-energized in optimal conditions. Any risk of phase opposition coupling must be avoided because this would cause transient electrical and mechanical phenomena that may damage the motor.

The protection determines the active power  $P$  of the motor and compares it to a threshold  $-|P_{set}|$ .

It is activated if  $P < -|P_{set}|$ .

It includes a definite time delay.

**Setting indications**

$$P_{set} = 5\% P_n.$$

Time delay = 1 second.

**Protection of generators against motor operation**

When a failure occurs in the driving system of the generator (turbine, diesel set, etc.), the generator operates as a synchronous motor and may damage the driving system.

The protection determines the active power  $P$  of the generator and compares it to a threshold  $P_{set}$ .

It is activated if  $P > P_{set}$ .

**Setting indications**

The setting threshold  $P_{set}$  is fixed:

- between 5% and 20% of the nominal power for a diesel set;
- between 1% and 5% of the nominal power for a turbine.

The time delay is above or equal to 1 second.

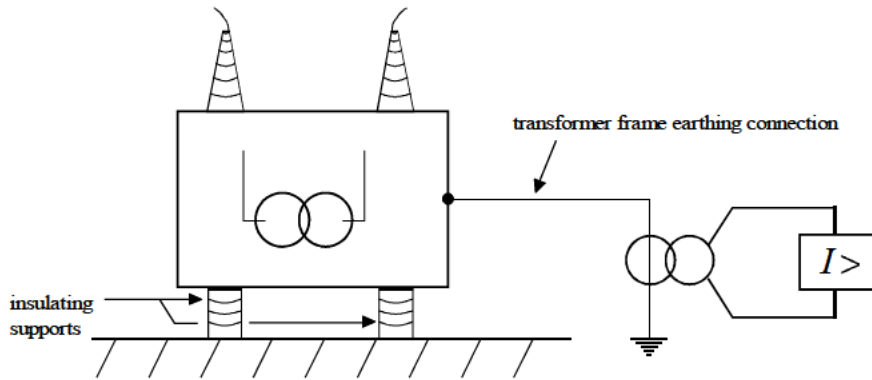
**7.20. Tank earth leakage protection (ANSI code 50 or 51)**

This protection is designed to protect a transformer against internal faults between a winding and the frame. It is recommended when the transformer power reaches 5 MVA.

**Principle**

This type of protection is an overcurrent protection and it is installed on the transformer frame earthing connection.

It requires the transformer to be insulated in relation to earth so that the fault current flows through the protection (see Figure 7-60).



**Figure 7-60:** tank earth leakage protection of a transformer

It is selective because it is only sensitive to transformer frame-earth faults.

Note: this protection can also be used to protect switchboards against frame-earth faults (switchboard earth leakage protection).

**Setting indications**

The setting threshold of the current can be fixed at 20 A.

For an earthing system using a limiting impedance, the threshold must be lower than or equal to 30% of the limiting current  $I_\ell$ .

For example, if  $0.3 I_\ell < 20 \text{ A}$  the current threshold  $I_{set}$  can be fixed at  $0.3I_\ell$ . The time delay is short if not zero.

**7.21. Protection against neutral earthing impedance overloads (ANSI code 50 N or 51 N)**

This protection allows the limiting impedance to be protected against the thermal effects of an overload.

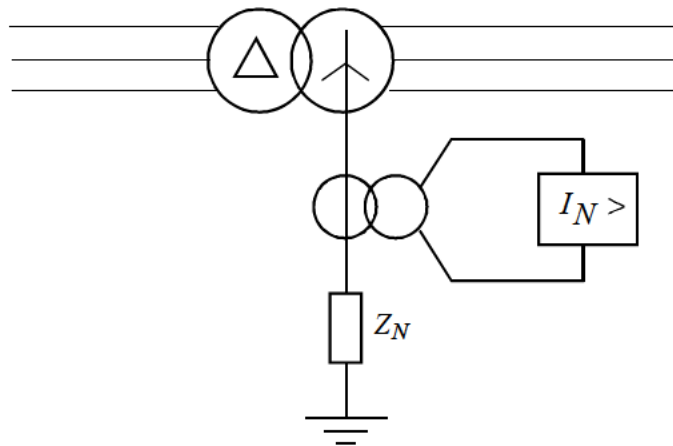
Indeed, when a phase-to-earth fault occurs on the network, the fault current is reclosed via the neutral earthing connection (see section 4.3).

If the fault is resistive, the fault current may be lower than the earth fault protection thresholds and higher than the permanent current that the resistor can

withstand. A permanent current thus flows through the limiting impedance and may damage it.

It can be protected using an overcurrent protection.

*Principle (see Figure 7-61)*



**Figure 7-61:** protection against neutral earthing impedance overloads

**Setting indications**

The current setting threshold must be lower than the permanent current that the resistor can withstand.

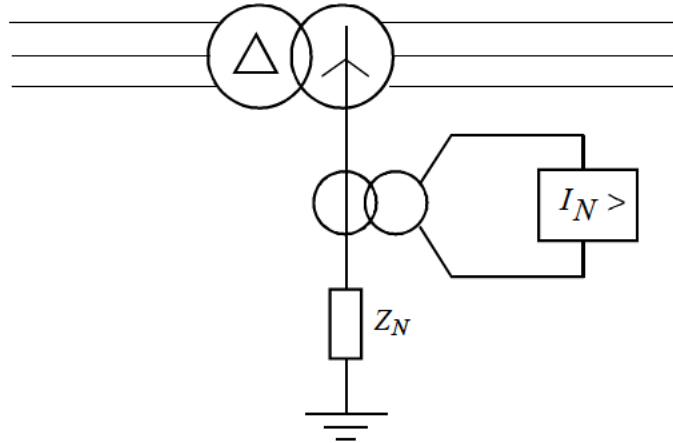
The time delay is several seconds.

**7.22. Overall network earth fault protection by monitoring the current flowing through the earthing connection (ANSI code 50 N or 51 N, 50 G or 51 G)**

This protection allows network phase-to-earth faults to be detected.

When a phase-to-earth fault occurs on the network, the fault current is reclosed via the neutral earthing connection (see section 4.3), and can be detected by the overall network earth fault protection.

*Principle (see Figure 7-62)*



**Figure 7-62:** overall network earth fault protection by monitoring the current flowing through the neutral earthing connection

The protection is activated when the current in the neutral rises above a threshold  $I_{set}$ .

It may be either of the definite time or inverse time type.

#### **Setting indications**

The threshold must be lower than the earth fault limiting current and depends on the selectivity system.

The time delay must be longer than all the time delays of the other network earth fault protection devices (except when a logical selectivity scheme is installed: see section 9.3).

### **7.23. Protection using temperature monitoring (ANSI code 38 – 49 T)**

This protection is used to monitor the internal temperature of a machine (transformer, generator, motor, etc.). It is associated with a platinum resistor type temperature probe inserted in the machine or on the bearings of a rotating machine.

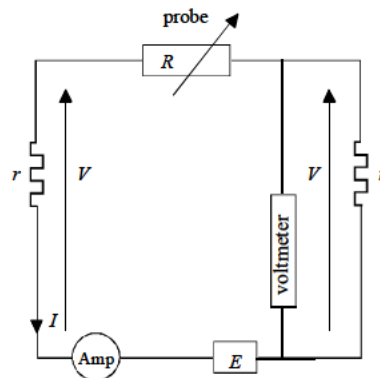
Temperature probes give excellent information for slow overloads. They are useful for operating machines that must, for a limited time period, withstand a load

current higher than the nominal current. Indeed, for slow variations in the load, it is quite permissible to accept a load current higher than the nominal current for as long as the temperature of the insulating material has not reached its permissible limit. The probes are, however, not very efficient at measuring rapid overloads because of the high value of the insulating material thermal time constant. Therefore, they should be used in association with overcurrent protection.

The protection generally indicates the probe faults (probe disconnected or short-circuited).

It usually has an alarm threshold and a tripping threshold.

Three-wire probes must be used to obtain correct measurement accuracy otherwise the measurement will be greatly falsified by the influence of the temperature on the resistance of the connecting wires (see Figure 7-63).



- $I$  : current measured by the ammeter  
 $V$  : voltage measured by the voltmeter  
 $E$  : voltage source  
 $r$  : connecting wire resistance

**Figure 7-63:** three-wire probe assembly

$$R = \frac{E - 2V}{I}$$

The resistance measurement, which characterizes the temperature of the environment, is independent of the connecting wire resistance  $r$ . Correct measurement accuracy is obtained.



### 7.24. Voltage restrained overcurrent protection (ANSI code 50 V or 51 V)

This protection is used to protect a generator against phase-to-phase faults downstream of the generator. It is particularly useful when the generator does not have a system for maintaining the short-circuit current at approximately  $3 I_n$  (see section 4.1.2).

As described in section 4.1.2, the short-circuit current downstream of a generator develops according to the three following periods:

- subtransient ( $X''_d$ ): lasting 10 to 20 ms after the start of the fault;
- transient ( $X'_d$ ): lasting up to 100 to 400 ms;
- synchronous ( $X_d$ ): steady-state or synchronous reactance to be considered after the transient period.

The synchronous reactance occurs after a period of approximately 100 to 400 ms. It has a value of roughly 200 to 350% (see Tables 4-3, 4-4 and 4-5).

We therefore have a permanent three-phase short-circuit current  $I_{sc} = \frac{1}{X_d(\%)} I_n$ , equal to between 0.3 and 0.5  $I_n$ , as long as the generator is not fitted with a system allowing the short-circuit current to be held at approximately  $3 I_n$  (see section 4.1.2).

Note: the minimum permanent short-circuit current is obtained for a three-phase short-circuit and is, in this specific case, lower than the phase-to-phase short-circuit current clear of earth. Indeed, according to section 4.2.3, the phase-to-phase short-circuit current clear of earth is:

$$I_{sc2} = \frac{\sqrt{3}V_n}{Z_{(1)} + Z_{(2)}}$$

thus  $I_{sc2} = \frac{\sqrt{3}V_n}{X_d + X_{(2)}}$  downstream of the generator, as its resistances are negligible compared with its reactances.

The value of  $X_{(2)}$  is approximately  $X''_d$ . It is very low compared with  $X_d$  (see Tables 4-3, 4-4 and 4-5), and can be neglected ( $X_d$  is 15 to 25 times higher than  $X''_d$ ).

Thus:

$$I_{sc2} \cong \frac{\sqrt{3}V_n}{X_d(\Omega)}$$

The permanent three-phase short-circuit current is:

$$I_{sc3} \cong \frac{V_n}{X_d(\Omega)}$$

Thus:

$$I_{sc3} \cong \frac{I_{sc2}}{\sqrt{3}}$$

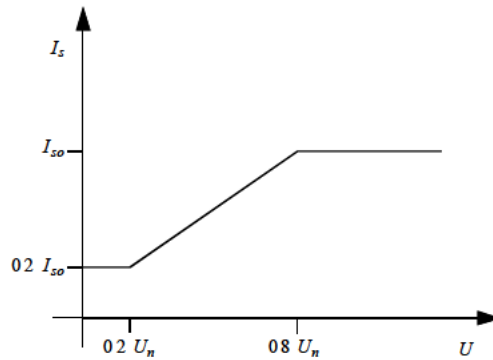
This means that the permanent three-phase short-circuit current is lower than the permanent phase-to-phase short-circuit current downstream of a generator.

Let us assume that, for reasons of selectivity, one wishes to protect the generator with a time delayed protection having a time longer than the transient period. The short-circuit current detected by the protection at the end of the time delay is lower than the nominal current ( $0.3$  to  $0.5I_n$ ), and it is therefore not possible to use conventional overcurrent protection.

This is why voltage restrained overcurrent protection is used.

### Principle

The current threshold is corrected by the voltage measurement (see Figure 7-64).



$I_{so}$ : current threshold for a voltage above  $0.8 U_n$

**Figure 7-64:** restrained voltage overcurrent protection principle

Let us take the example of a generator with a synchronous impedance  $X_d=300\%$ . The minimum permanent short-circuit current is therefore

$$I_{sc} = \frac{1}{X_d(\%)} I_n, \text{ hence } I_{sc} = 0.33 I_n.$$

Due to the synchronous impedance being very high, the impedances of the cables and transformers downstream of the generator are negligible and do not therefore influence the value of the permanent short-circuit current. For the same reasons, upon occurrence of a short-circuit, the voltage measured at the location point of the generator is very low, i.e. lower than  $0.2 U_n$ .

If the threshold  $I_{so}$  is set at  $1.2 I_n$ , upon occurrence of a short-circuit downstream of the generator with the voltage dropping to a value lower than  $0.2 U_n$ , the current threshold takes on the value  $I_s = 0.2 I_{so}$ , thus  $I_{set} = 0.24 I_n$ .

The minimum short-circuit current is equal to  $0.33 I_n$  and the protection is therefore activated.

The protection may be either of the definite time or inverse time type.

*Operating example: the Schneider Sepam 2000*

The protection is activated when one, two or three of the phase currents reach the current threshold corrected by the voltage.

The current threshold is corrected by the voltage measurement in the following way:

$$I_{set} = I_{so} \quad \text{for } U \geq 0.8 U_n$$

$$I_{set} = \left[ 4 \frac{U}{U_n} - 0.2 \right] \frac{I_{so}}{3} \quad \text{for } 0.2 U_n < U < 0.8 U_n$$

$$I_{set} = 0.2 I_{so} \quad \text{for } U \leq 0.2 U_n$$

### **Setting indications**

The current threshold  $I_{so}$  can be set at  $1.2 I_n$ .

The permanent short-circuit current must respect the following condition:

$$I_{psc} > 0.2 I_{so}$$

thus:

$$I_{psc} > 0.24 I_n$$

This condition is met as long as the synchronous impedance  $X_d$  is lower than 415%, which is generally the case (see Tables 4-3, 4-4 and 4-5).

The time delay, fixed by the selectivity system, can be longer than the duration of the transient period.

Note: restrained voltage overcurrent protection is also referred to as minimum impedance protection. Indeed, according to Figure 7-64, we can see that the protection is activated for a constant ratio  $\frac{U}{I}$ , i.e. a threshold impedance  $Z_{set}$ . Physically, it can be said that the protection measures the impedance downstream and, when this is lower than the threshold  $Z_{set}$ , the protection is activated. The low value of the downstream impedance is characteristic of a short-circuit or a high overload.

### 7.25. Protection by gas, pressure and temperature detection (DGPT)

The DGPT (detection of gas, pressure and temperature) is a protective device used for liquid-insulated transformers.

It detects anomalies inside the liquid dielectric such as emission of gas, or a rise in pressure or temperature, and causes the transformer switching device (circuit-breaker or switch-fuse) to trip.

The relay units corresponding to these functions are mainly designed to protect “totally filled”, sealed and immersed transformers.

This protection can carry out the following four functions.

#### ***Detection of gaseous emission***

In a liquid-insulated transformer, an internal fault always causes a fairly large gaseous emission due to the decomposition of the insulating materials (liquids or solids) under the action of the electric arc.

#### ***Detection of a sealing anomaly indicated by a drop in the dielectric level***

There are two levels of detection:

- a visual indication of a drop in the level via a first red floater;

– electrical message to the switching device operating mechanism via a second floater when there is a large drop in the level.

Note: the transformer can be easily refilled via the upper part of the relay unit.

***Detection of excessive pressure in the transformer tank using an electrical contact pressure switch***

This pressure switch is pre-set in the factory by the transformer manufacturer to between 0 and 500 millibars (normal value: 200 millibars).

When an internal fault due to a high short-circuit current occurs, the gaseous emission causes the pressure switch to be activated in several tenths of a second.

***Detection of an abnormal temperature in the dielectric***

This detection is both visual (thermometer with 0 to 120°C graduations) and electrical (1 or 2 thermostats). These thermostats (liquid expansion-based) are independent and can be set to between 30 and 120°C (increments of 5°C), with one giving the alarm (normal setting: 95°C), and the other causing the switching device to trip (normal setting: 100°C).

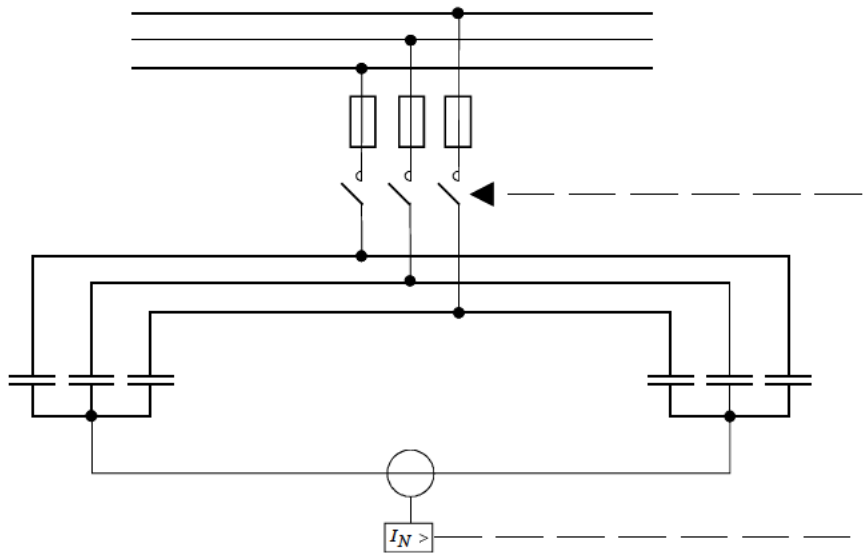
The sensitive part of the thermometer is located in the same pocket tube as that of the thermostat probes.

Note: a Buchholz relay provides protection for a breathing transformer. For a fault that is not very serious, the gaseous emission is collected in an upper part of the relay and an alarm is activated when too much gas accumulates. For a serious fault, the large quantities of gas produced forcefully drives back part of the oil in the tank towards the conservator. A floater driven by the oil flux gives the order for the transformer to be put out of service. This principle leads to an operating time of several tenths of a second for a serious fault.

**7.26. Neutral to neutral unbalance protection (ANSI code 50 N or 51 N)**

This protection is designed to protect double star-connected capacitor banks (see Figure 7-65).

The deterioration of the capacitor elements leads to an unbalance that causes a current to circulate between the two neutral points (see section 10.6.3). This current is detected by the protection, which causes the switching device to trip.



**Figure 7-65:** protection of a double star-connected capacitor bank

**Principle**

The protection is activated when the current circulating in the link between the two neutral points rises above the setting threshold.

The time delay may be either of the independent time or inverse time type.

**Setting indications**

The current threshold is given by the manufacturer.

The time delay may be fixed at 0.1 second.

## Chapter 8

# Overcurrent Switching Devices

Overcurrents in an electrical network may be caused by a short-circuit or an overload. The switching devices used to clear these overcurrents are circuit-breakers and fuses.

In this chapter we will define the electrical specifications of fuses and circuit-breakers.

Since low and medium voltage specifications are different, they will be dealt with in separate sections.

### ***Definition***

*Prospective short-circuit current*: this is the short-circuit current in steady-state operating conditions that would occur if the impedance of the switching device was zero.

### **8.1. Low voltage circuit-breakers**

#### ***Rated <sup>(1)</sup> operating voltage $U_e$***

This is, or these are, the voltage(s) at which the device can be used.

#### ***Rated <sup>(1)</sup> current $I_n$***

This is the maximum value of the current that a circuit-breaker, fitted with a tripping relay, can withstand at an ambient temperature specified by the manufacturer and in compliance with the specified heating limits.

Nevertheless, a circuit-breaker can be used at higher ambient temperatures if it is derated. Thus, a circuit-breaker with a rated current of 125 A will only be able to withstand 117 A at 50°C and 109 A at 60°C.

**Frame-size rating of a circuit-breaker**

When a circuit-breaker is fitted with several tripping relays with different current ratings, the frame-size of the breaker matches the highest current rating of the tripping relays with which it can be fitted.

**Overload relay trip current setting  $I_{rth}$  or  $I_r$**

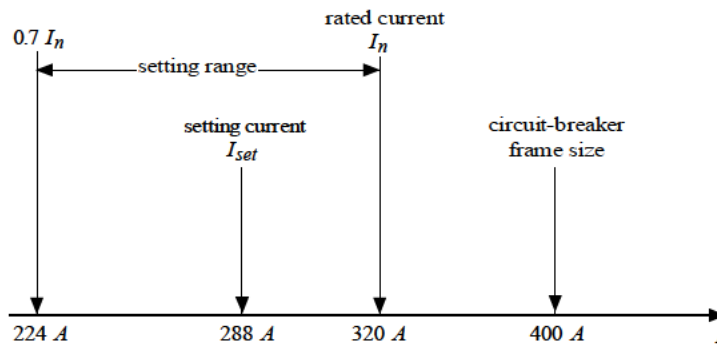
With the exception of small circuit-breakers (Multi 9 type for Schneider circuit-breakers), which are easily replaced, industrial circuit-breakers are fitted with removable overcurrent-trip relays. Moreover, to adapt the circuit-breaker to the circuit specifications and to avoid the need to install oversized cables, the tripping relays are generally adjustable.

The setting current  $I_r$  (or  $I_{rth}$ ) is the current that determines the protection conditions provided by the circuit-breaker. It also represents the maximum current that the circuit-breaker can withstand without tripping.

This value must be greater than the operating current but less than the maximum current permitted in the trunking. The thermal-trip relays can generally be set between  $0.7 \times I_n$  and  $1 \times I_n$ , whereas in electronic devices the ranges are usually much wider (currently between  $0.4$  and  $1 \times I_n$ ). Setting is not continuous but is carried out in steps. This must be taken into account when studying the selectivity.

**Example (see Figure 8-1)**

A circuit-breaker with 400 A rated current fitted with a tripping relay of 320 A set at 0.9; has a trip-current setting:  $I_r = 320 \times 0.9 = 288$  A.



**Figure 8-1:** circuit-breaker with 400 A rated current fitted with a tripping relay 320 A set at 0.9



**Short-circuit relay trip-current setting ( $I_m$ )**

Short-circuit tripping relays (magnetic or slightly time delayed) are designed to cause high-speed opening of the circuit-breaker upon occurrence of high overcurrents.

Their operating threshold  $I_m$  is either fixed by standards (e.g. IEC 60898 for domestic circuit-breakers, or stipulated by the manufacturer for industrial circuit-breakers governed by IEC 60947-2):

- for the latter circuit-breakers, there is a wide variety of tripping relays allowing the user to adapt the protective functions of the device to the requirements of the circuit to be protected, even in the most specific cases;
- for circuit-breakers with adjustable thresholds, setting is not continuous but carried out in steps. This must be taken into account when studying the selectivity.

Table 8-1 gives the average circuit-breaker operating thresholds for overloads and short-circuits. Figures 8-2 and 8-3 give the standard operating curves for a thermal-magnetic circuit-breaker and an electronic circuit-breaker.

Some tripping relays have an  $I^2 \times t = \text{constant}$  curve as an option.

	type of trip-relay	overload protection	short-circuit protection		
IEC 60898 domestic circuit-breakers	thermal-magnetic	$I_r = I_n$	low setting type B $3I_n \leq I_m < 5I_n$	standard setting type C $5I_n \leq I_m < 10I_n$	high setting type D $10I_n \leq I_m < 20I_n$
modular industrial circuit-breakers	thermal-magnetic	fixed: $I_r = I_n$	low setting type B or Z $3.2I_n < \text{fixed} < 4.8I_n$	standard setting type C $7I_n < \text{fixed} < 10I_n$	high setting type D or K $10I_n < \text{fixed} < 14I_n$
IEC 60947-2 industrial circuit-breakers	thermal-magnetic	fixed: $I_r = I_n$	fixed: $I_m \approx 7 \text{ to } 10I_n$		
		adjustable: $0.7I_n \leq I_r < I_n$	adjustable: - low setting: 2 to $5I_n$ - standard setting: 5 to $10I_n$		
	electronic	long delay (LD) $0.4I_n \leq I_r < I_n$	adjustable short delay (SD) $1.5I_r \leq I_m < 10I_n$ instantaneous (I) fixed $I \approx 12 \text{ to } 5I_n$		

**Table 8-1:** average circuit-breaker operating thresholds for overloads and short-circuits

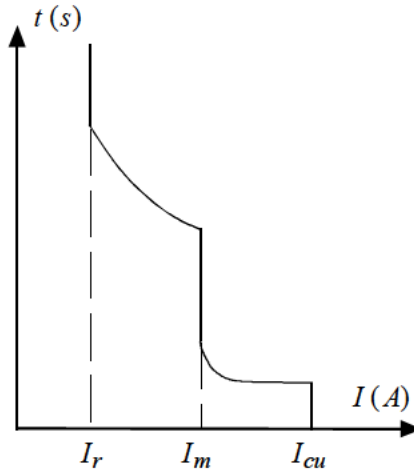


Figure 8-2: standard operating curve for a thermal-magnetic circuit-breaker

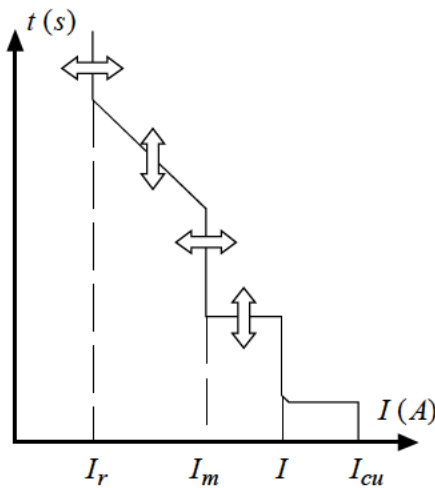


Figure 8-3: standard operating curve for an electronic circuit-breaker

**Breaking capacity ( $I_{cu}$  or  $I_{cn}$ )**

The breaking capacity is the highest short-circuit current (prospective current) that a circuit-breaker can interrupt under a given voltage. It is generally expressed in symmetrical r.m.s. kA and is designated by  $I_{cu}$  (ultimate breaking capacity) for industrial circuit-breakers, and  $I_{cn}$  (rated breaking capacity) for circuit-breakers for domestic or similar use.

The conditions for determining the breaking capacity are stipulated by standards and they include the following:

*Operating sequence*

The circuit-breaker carries out a succession of switching manoeuvres: opening then closing/opening upon occurrence of a short-circuit (O-CO cycle).

*Current/voltage phase displacement*

When the voltage and current are in phase ( $\cos \varphi = 1$ ), the short-circuit current is easier to interrupt.

It is much more difficult when the  $\cos \varphi$  is small. The standards define the  $\cos \varphi$  to be used to determine the breaking capacity of a device. The higher the breaking capacity, the smaller the  $\cos \varphi$ , since the matching circuit-breakers are installed near the transformers and busbars, the impedance of which is essentially inductive.

Table 8-2 gives the conditions for determining the breaking capacity of industrial circuit-breakers in relation to  $\cos \varphi$ .

$I_{cu}$	$\cos \varphi$
$6 \text{ kA} < I_{cu} \leq 10 \text{ kA}$	0.5
$10 \text{ kA} < I_{cu} \leq 20 \text{ kA}$	0.3
$20 \text{ kA} < I_{cu} \leq 50 \text{ kA}$	0.25
$50 \text{ kA} < I_{cu}$	0.2

**Table 8-2:** relation between  $I_{cu}$  and  $\cos \varphi$  (according to standard IEC 60947-2)

*Post breaking test*

After the O-CO cycle, the circuit-breaker should be checked to make sure that it is still able to provide a smaller number of operations (dielectric withstand capability, operation of trip relays, disconnectability).

**Rated insulation voltage ( $U_i$ )**

This is the voltage value used as a reference for the dielectric performances of the device.

The maximum operating voltage of a circuit-breaker can only be lower than or equal to  $U_i$ :

$$U_e \leq U_i$$

**Rated impulse-withstand voltage ( $U_{imp}$ )**

This specification, expressed in impulse kV, indicates the capacity of a device to resist transient voltages likely to occur during use.

Generally,  $U_{imp} = 8 \text{ kV}$  for industrial circuit-breakers, and  $U_{imp} = 6 \text{ kV}$  for domestic circuit-breakers.

**Short-time withstand current ( $I_{cw}$ ) category (A or B)**

For industrial circuit-breakers (IEC 60947-2), there are two device categories:

- those belonging to category A for which there is no tripping delay upon occurrence of a short-circuit (see Figure 8-4);
- those belonging to category B for which, in order to ensure time-graded selectivity, it is possible to delay tripping upon occurrence of short-circuit currents that are lower than the short-time withstand current  $I_{cw}$  (see Figure 8-5).  $I_{cw}$  is the maximum current that a category B type circuit-breaker can thermally and electro-dynamically withstand for a time specified by the manufacturer.

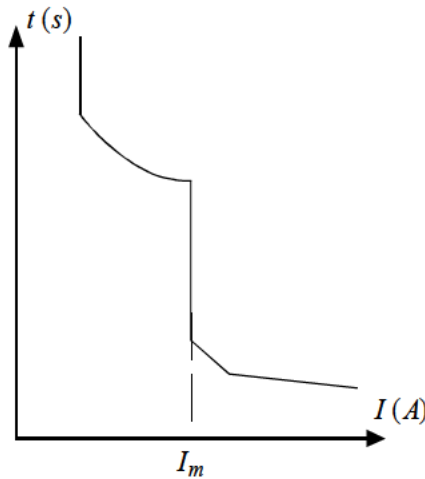


Figure 8-4: category A circuit-breaker

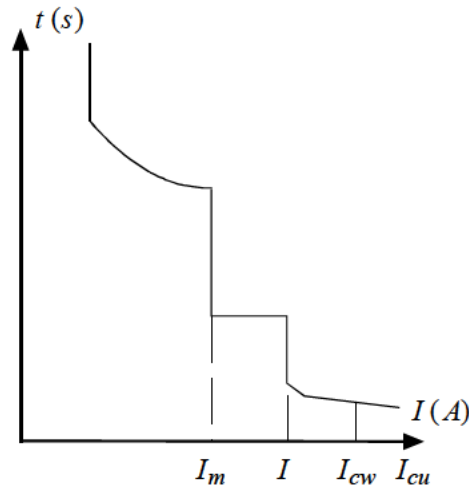


Figure 8-5: category B circuit-breaker

**Making capacity ( $I_{cm}$ )**

This is the highest current that the circuit-breaker can make under the rated voltage in specified conditions. In an alternating current, it is expressed by the peak value of the current (see section 4.1). The making capacity is equal to  $K$  times the breaking capacity,  $K$  being given in Table 8-3.

$I_{cu}$	$\cos \varphi$	$I_{cm} = K \times I_{cu}$
$6 \text{ kA} < I_{cu} \leq 10 \text{ kA}$	0.5	$1.7 \times I_{cu}$
$10 \text{ kA} < I_{cu} \leq 20 \text{ kA}$	0.3	$2 \times I_{cu}$
$20 \text{ kA} < I_{cu} \leq 50 \text{ kA}$	0.25	$2.1 \times I_{cu}$
$50 \text{ kA} < I_{cu}$	0.2	$2.2 \times I_{cu}$

**Table 8-3:** relation between  $I_{cu}$ ,  $I_{cm}$  and  $\cos \varphi$  (according to IEC 60947-2)

### **Rated service short-circuit breaking capacity ( $I_{cs}$ )**

The breaking capacity ( $I_{cu}$  or  $I_{cn}$ ) represents the maximum short-circuit current that the circuit-breaker may have to interrupt. The probability of such a fault occurring is extremely low and, during use, a circuit-breaker generally only has to interrupt much lower currents.

However, it is important that these currents, which are much more likely to occur, are interrupted in extremely good conditions so as to guarantee that the installation is put back into service quickly and in complete safety once the cause of the fault has been cleared.

This is why standards have defined a new specification,  $I_{cs}$ , which is generally expressed as a percentage (25, 50, 75 or 100%) of  $I_{cu}$  for industrial circuit-breakers.

Service breaking performance is checked as follows:

- O - CO - CO (at  $I_{cs}$ ) test sequence;
- post-breaking tests to check that the circuit-breaker is able to operate normally.

For domestic circuit-breakers  $I_{cs} = k I_{cn}$ . The factor  $k$  values are given in IEC 60898, Table XIV.

### **Fault-current limitation**

The fault-current limiting capacity of a circuit-breaker is its ability to only allow a current lower than the prospective fault current to flow upon occurrence of a short-circuit (see Figure 8-6).

This specification is given by limitation curves that show:

- the limited peak current in relation to the r.m.s. value of the prospective short-circuit current;

– the limited thermal effect in relation to the r.m.s. value of the prospective short-circuit current.

Manufacturers supply the limitation specifications for all circuit-breakers in the form of curves in relation to the r.m.s. value of the prospective short-circuit current. Figure 8-7 gives an example of the limitation curve of a circuit-breaker.

LV circuit-breakers for domestic and similar use are classified in certain standards (notably European standard EN 60 898). If the limitation class is provided, the manufacturer does not supply the characteristic performance curves.

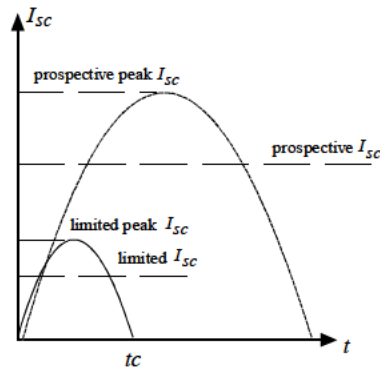


Figure 8-6: prospective current and actual limited current

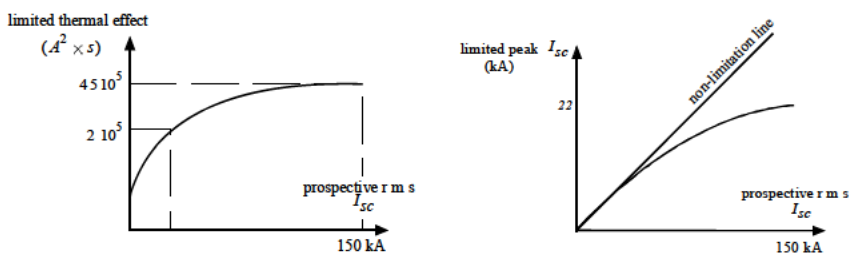


Figure 8-7: limitation curves of a Compact C161L circuit-breaker

***Advantages of current limitation***

The use of current-limiting circuit-breakers provides numerous advantages:

- better network protection: limiting circuit-breakers greatly reduce all the harmful effects of short-circuit currents in an installation;
- reduction of thermal effects: a smaller heat rise in the conductors leading to increased cable life;
- reduction of mechanical effects: electrodynamic forces of repulsion (see section 5.2) are reduced, so there is less risk of elements being deformed or ruptured, especially the electrical contacts;
- reduction of electromagnetic effects: less influence on measuring instruments located near an electrical circuit.

These circuit-breakers contribute to improving the protection of:

- cables;
- prefabricated trunking;
- electrical switchgear.

This means that they slow down installation aging.

***Example***

For a prospective short-circuit current of 150 kA r.m.s., a circuit-breaker limits the peak current to less than 10% of the value calculated and the thermal effects (proportional to the square of the current; see section 5.1) to less than 1% of the calculated effects.

**8.2. MV circuit-breakers (according to standard IEC 62271-100)*****The rated short-circuit breaking capacity***

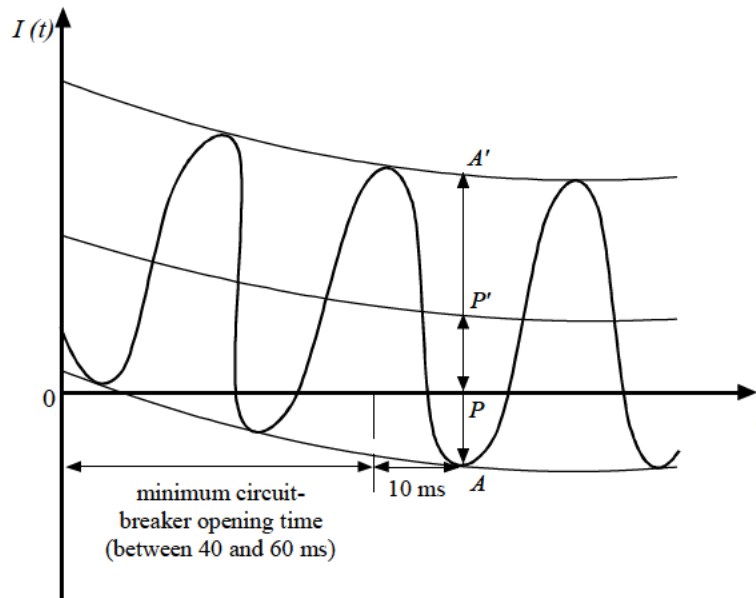
This is the highest short-circuit current that the circuit-breaker is able to interrupt.

The rated short-circuit breaking capacity is characterized by two values (see IEC 62271-100, section 4.101):

- the r.m.s. value of its AC component (see section 4.1), termed “rated short-circuit breaking capacity” for short;
- the DC component percentage (see section 4.1).

The percentage of DC component is the ratio between the DC component and the AC component during the minimum opening time of the circuit-breaker,

increased by a half period, i.e. 10 ms at 50 Hz (see Figure 8-8). The half period corresponds to the minimum activation time of an overcurrent protection.



- $PP'$  : represents the value of the DC component
- $\frac{AA'}{2\sqrt{2}}$  : represents the r.m.s. value of the AC component
- $OP = \tau$  : represents the minimum opening time of the circuit-breaker (roughly 40 to 60 ms) increased by half a period (10 ms at 50 Hz)
- $\frac{PP'}{\left(\frac{AA'}{2\sqrt{2}}\right)} \times 100$  : percentage value of the DC component

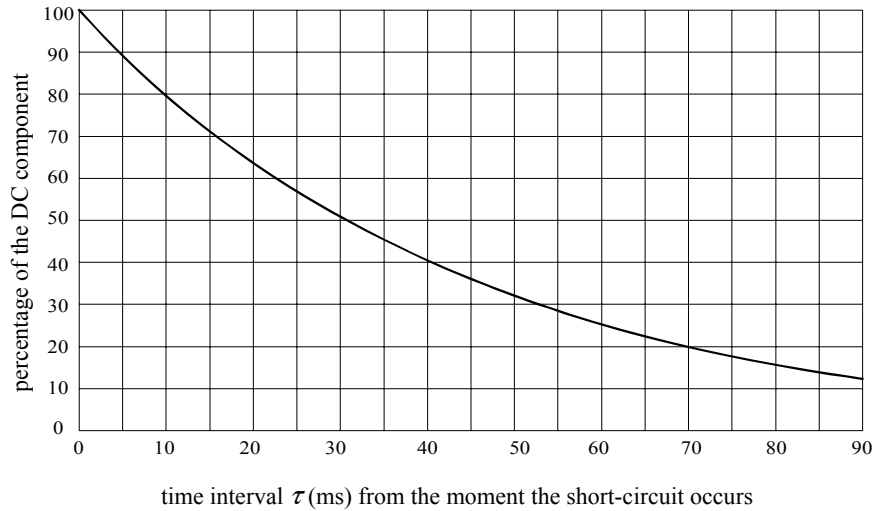
**Figure 8-8:** definition of the percentage of the DC component

The circuit-breaker must be able to interrupt all short-circuit currents such that:

- the AC component is lower than or equal to the rated value;
- the percentage of the DC component is lower than or equal to the specified value.

IEC 62271-100 indicates the *normal* values of the percentage of the DC component in relation to a time interval  $\tau$  from the moment the short-circuit occurs (see Figure 8-9).





**Figure 8-9:** *percentage of the DC component in relation to the time interval  $\tau$  from the moment the short-circuit occurs*

For a minimum circuit-breaker opening time of 40 ms to 60 ms increased by 10 ms, i.e. a time  $\tau$  of 50 to 70 ms, the percentage of DC component is 33% to 21%.

A circuit-breaker with a minimum opening time of 40 ms must therefore be able to interrupt a DC component percentage of 33%.

A circuit-breaker with a minimum opening time of 60 ms must therefore be able to interrupt a DC component percentage of 21%.

Note: for a time interval  $\tau$  greater than or equal to 80 ms, IEC 62271-100 does not stipulate the use of breaking tests including a DC component. Circuit-breakers with a minimum opening time greater than or equal to 70 ms (at 50 Hz) do not have a DC component specification.

The percentage curve of the DC component defined by IEC 62271-100 corresponds to a time constant of 45 ms, i.e. to the following equation:  $e^{-\frac{\tau}{45}}$  where  $\tau$  is in ms.

Indeed, for  $\tau = 45$  ms, the percentage value of the DC component measured on the curve is 37%, i.e.  $\frac{1}{e} \times 100$ .

According to section 4.1.1, the time constant of 45 ms corresponds to the ratio  $\frac{X}{R\omega} = 45 \text{ ms}$ .

i.e.

$$\frac{R}{X} = \frac{1}{45 \times 10^{-3} \times 2\pi \times 50} = 0.071$$

This means that the normal percentage value of the DC component defined by IEC 62271-100 is suitable for a short-circuit current fed by the utility (far away from the generators), as the ratio  $\frac{R}{X}$  is normally higher than 0.071, thus giving a DC component percentage lower than the values defined by the standard.

However, for circuit-breakers located near high power generators, the DC time constant is much greater than 45 ms.

The DC component percentage at the moment the circuit-breaker opens (+  $\frac{1}{2}$  period) is thus greater than the value defined in Figure 8-9. IEC 62271-100 stipulates that, for these special applications, the percentage of DC component required is in theory specified in the tender document and tests are subject to agreement between the manufacturer and user.

Note: the ratio  $\frac{R}{X}$  of the power supplied by the utility may be lower than 0.071 for a short-circuit occurring near an HV/MV transformer. For example, for a Jeumont Schneider 90 kV/21 kV transformer of 36 MVA with a 17% short-circuit voltage, the ratio is as follows:  $\frac{R}{X}=0.031$ . For a short-circuit occurring near this transformer, the ratio  $\frac{R}{X}$  is approximately 0.03. The DC component percentage is thus greater than the normal value defined by IEC 62271-100. According to section 4.1.1, for  $\tau = 50 \text{ ms}$ , the calculation gives 61% of DC component. In this case, it is necessary to check the circuit-breaker breaking capacity with the manufacturer. If the breaking capacity is too low, interruption of the short-circuit current can be time-delayed by the protection. In which case, interruption takes place when the DC component has been sufficiently reduced. In the example above, using a time delay of 100 ms,  $\tau_1 = \tau + 100 = 150 \text{ ms}$ . According to section 4.1.1, we find 23% of DC component, i.e. a value lower than the normal value given in IEC 62271-100 (33% for a minimum opening time of 40 ms).

**Rated short-circuit making capacity**

The circuit-breaker must be able to be closed upon occurrence of a short-circuit. The electrodynamic effect that it undergoes (see section 5.2) depends on the peak value of the short-circuit current. This peak value is defined by a coefficient  $K$  (see section 4.1.1), such that the peak value of the short-circuit current is equal to  $K$  times the r.m.s. value of the short-circuit current in steady-state operating conditions.

IEC 62271-100, section 4.103, stipulates that the rated short-circuit making capacity must be 2.5 times the r.m.s. value of the AC component of its rated short-circuit breaking capacity.

This means that the circuit-breaker can be closed upon occurrence of a short-circuit with a coefficient of  $K \leq 2.5$ , having a value equal to its rated short-circuit breaking capacity.

$$\text{According to section 4.1.1, } K = \sqrt{2} \left( 1 + e^{-\frac{R}{X}\pi} \right).$$

from which the value of  $\frac{R}{X}$  is deduced for  $K = 2.5$ , i.e.:

$$\frac{R}{X} = -\frac{1}{\pi} \operatorname{Ln} \left( \frac{2.5}{\sqrt{2}} - 1 \right)$$

$$\frac{R}{X} = 0.084$$

This means that the making capacity defined by IEC 62271-100 is suitable for a short-circuit current whose ratio  $\frac{R}{X}$  is greater than 0.084, which is generally the case. If it is not the case, a circuit-breaker with a breaking capacity above  $\frac{K}{2.5} I_{sc}$  must be chosen, where:

$$K = \sqrt{2} \left( 1 + e^{-\frac{R}{X}\pi} \right)$$

$I_{sc}$ : maximum short-circuit current

Note 1: ANSI stipulates a making capacity with a coefficient  $K = 2.7$  corresponding to a ratio  $\frac{R}{X} = 0.03$ . Most Schneider circuit-breakers comply with IEC and ANSI standards and thus have a making capacity with a coefficient  $K = 2.7$ .

Note 2: the ratio  $\frac{R}{X}$  may be lower than 0.084 for a short-circuit occurring near an HV/MV transformer. For example, for a Jeumont Schneider 90 kV/21 kV transformer of 36 MVA with a 17% short-circuit voltage, we have a ratio  $\frac{R}{X} = 0.031$ . For a short-circuit occurring near the transformer, we thus have a ratio  $\frac{R}{X}$  of approximately 0.03; hence  $K = \sqrt{2} (1 + e^{-0.03\pi}) = 2.70$ .

Note 3: for circuit-breakers located near high power generators, the peak value of the short-circuit current must be accurately calculated and a check must be carried out on the circuit-breaker to make sure that its making capacity is higher than the peak value of the short-circuit current.

#### ***Rated allowable short-time withstand current***

IEC 62271-100, section 4.5, stipulates that the rated allowable short-time withstand current must be equal to the rated short-circuit breaking capacity.

#### ***Rated short-circuit time***

This is the time interval during which the circuit-breaker, in closed position, can withstand a current equal to the rated allowable short-time withstand current.

The normal value of the rated short-circuit time is 1 second (see IEC 60694, section 4.7). This time interval corresponds to the short-circuit time that the circuit-breaker must be able to withstand for reasons of selectivity.

This is the case, for example, when independent time phase overcurrent protection (see section 7.1) is time delayed by 1 second.

When, for reasons of selectivity, the user requires a time delay  $T$  above 1 second, the allowable short-time current that the circuit-breaker can withstand can be determined by:

$$(I_{ast})^2 \times T = \text{constant}$$

$I_{ast}$  : allowable short-time withstand current

*Example*

Let us take a circuit-breaker with an allowable short-time withstand current of 34 kA for 1 second.

Let us assume that, owing to the selectivity requirements, a time delay of 2 seconds is necessary.

The allowable short-time withstand current is thus:

$$(I_{ast})^2 \times 2 s = (34 kA)^2 \times 1 s$$

$$I_{ast} = 24 kA \text{ for 2 seconds}$$

Note 1: the rated short-circuit time is sometimes called the “thermal withstand”.

Note 2: a rated short-circuit time of 3 seconds is sometimes required by users and it is mentioned in IEC 60694 (see section 4.7).

**8.3. Low voltage fuses**

These are available with or without mechanical blown-fuse indicator lamps.

Fuses are basically protective switchgear designed to trip all or part of a circuit by the blowing of one or more fuses when the current rises above a given value for a specified time.

Standards define two types of fuses according to their application:

- fuse for domestic use, which takes gG type cartridges (IEC 60269-3);
- fuse for industrial use, which takes gG or gM type cartridges (IEC 60269-1 and 2).

Domestic and industrial fuses can be differentiated essentially by their operating voltages, size and breaking capacities.

**8.3.1. Fusing zones – conventional currents**

The fusing conditions of a fuse are defined by standards according to the fuse class.

***Class gG fuses***

These fuses ensure protection against overloads and short-circuits.

The conventional fusing and non-fusing currents are standardized (see Figure 8-10 and Table 8-4):

- The conventional non-fusing current  $I_{nf}$  is the current value that a fuse element can withstand for a specified time without melting. *Example:* a 32 A fuse through which a  $1.3 I_n$  current (i.e. 41.6 A) flows must not melt within the first hour.

- The conventional fusing current  $I_2$  is the current value that causes the fuse to blow before the specified time is up. *Example:* a 32 A fuse through which a  $1.6 I_n$  current (i.e. 52.1 A) flows must melt within the first hour.

These two specifications explain why:

- the fuses are not suitable for protection against low overloads (high conventional fusing current);
- a cable cross-section able to carry a current that is higher than the operating current must be used in order to avoid damage to the cable upon occurrence of an overload current of long duration whose value is lower than the fuse specifications.

By way of comparison, a circuit-breaker:

- through which a  $1.05 I_n$  current flows must not be tripped within the first hour;
- through which a  $1.25 I_n$  current flows must be tripped in less than an hour.

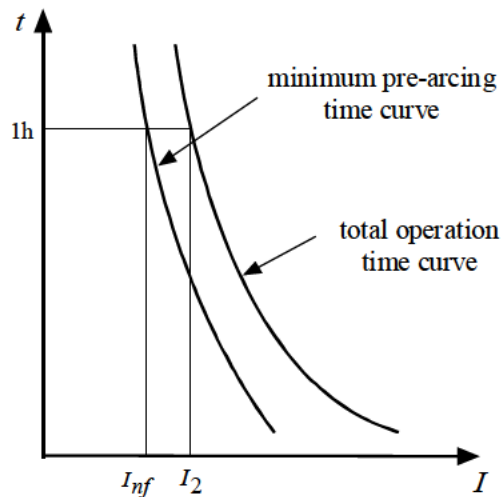


Figure 8-10: fusing and non-fusing zones for a gG fuse

Class	Rated current $I_n$ (A)	Conventional non-fusing current $I_{nf}$ (A)	Conventional fusing current $I_2$
gG	$I_n \leq 4 A$	$1.5 I_n$	$2.1 I_n$
	$4 < I_n \leq 10 A$	$1.5 I_n$	$1.9 I_n$
	$10 < I_n \leq 25 A$	$1.4 I_n$	$1.75 I_n$
	$I_n > 25 A$	$1.3 I_n$	$1.6 I_n$

Table 8-4: rated currents and conventional currents for fuses

**Class gM fuses (motor associated fuses)**

These fuses only ensure protection against short-circuits and are used especially in association with other devices (discontactor, circuit-breakers) to provide protection against any overload above  $4 I_n$ . They are therefore not autonomous. Because gM fuses are not designed to protect against low overloads, the conventional fusing or non-fusing currents are not fixed. They are activated from approximately  $4 I_n$  (see Figure 8-11).

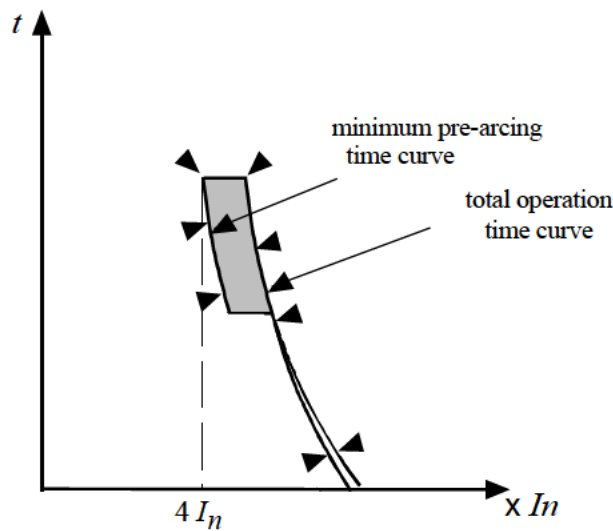


Figure 8-11: standardized fusing zones for a gM fuse

### 8.3.2. Breaking capacity

Fuses are characterized by their excellent breaking capacity, which is extremely useful when considerable short-circuits occur. This is due to the fusing speed that enables the fault current to be cleared before it reaches its maximum value.

This is what is referred to as limitation and it has the advantage of reducing thermal and mechanical effects caused by a short-circuit (see Figure 8-12).

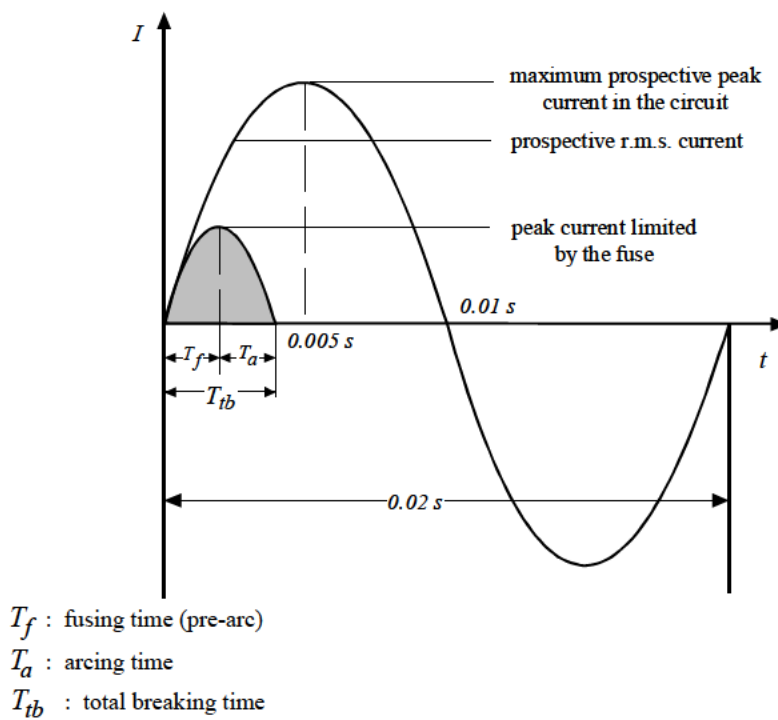


Figure 8-12: short-circuit current limited by a fuse

### 8.4. MV fuses

MV fuses are defined by standard IEC 60282-1. They are commonly used to protect transformers, motors and other loads.

They have a number of advantages such as:

- low cost;
- limitation of the short-circuit current.



This last feature means that the thermal and electrodynamic effects of short-circuit currents are limited (see section 5.1 and 5.2), which is an advantage in relation to MV circuit-breakers.

### Definition

*The pre-arc:* this is the fusing time of the fuse before the electrical arc occurs.

$U_n$ : *rated voltage:* this is the highest phase-to-phase voltage (expressed in kV) in the network on which the fuse can be installed. In the MV range, preferential rated voltages have been fixed: 3.6 - 7.2 - 12 - 17.5 - 24 - 36 (kV).

$I_n$ : *rated current (see Figure 8-13):* this is the value of the current that the fuse can permanently withstand without overheating (usually 65°C for the contacts).

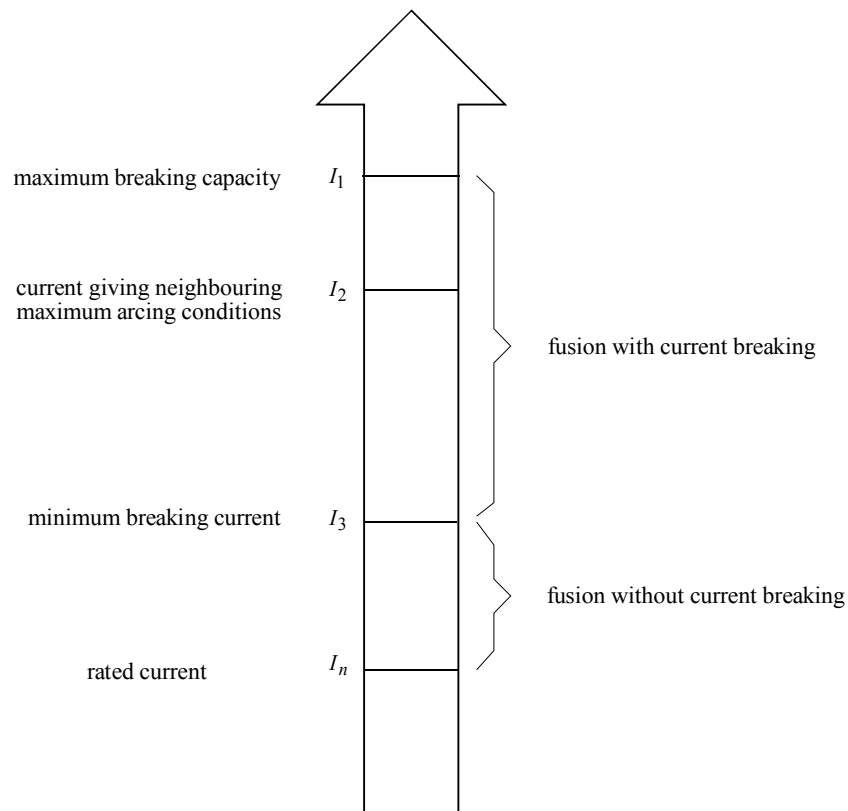
$I_3$ : *minimum breaking current (see Figure 8-13):* this is the minimum current value that causes the fuse to fuse and break the current. The  $I_3$  values are usually between 2 and 6  $I_n$ .

Note: the melting of an MV fuse is not enough to cause interruption of the current flow. For current values below  $I_3$ , the fuse melts but does not break the current. The arc remains until the current is interrupted by an external operation. It is thus *essential* to avoid a current of *between  $I_n$  and  $I_3$*  flowing through the fuse.

$I_2$ : *current giving conditions close to the maximum arc energy (see Figure 8-13):* the value of  $I_2$  depends on the design of the fuse elements and is situated between 20 and 100  $I_n$ . It ensures that breaking for the entire current zone between  $I_3$  and  $I_1$  is guaranteed.

$I_1$ : *current giving a maximum breaking capacity (see Figure 8-13):* this is the maximum prospective short-circuit current that the fuse can interrupt. It is the maximum testing value of the fuse: between 20 kA and 50 kA.

Note: It is therefore necessary to ensure that the network short-circuit current is at the most equal to the current  $I_1$  of the fuse used.



**Figure 8-13:** definition of the operating zones of an MV fuse

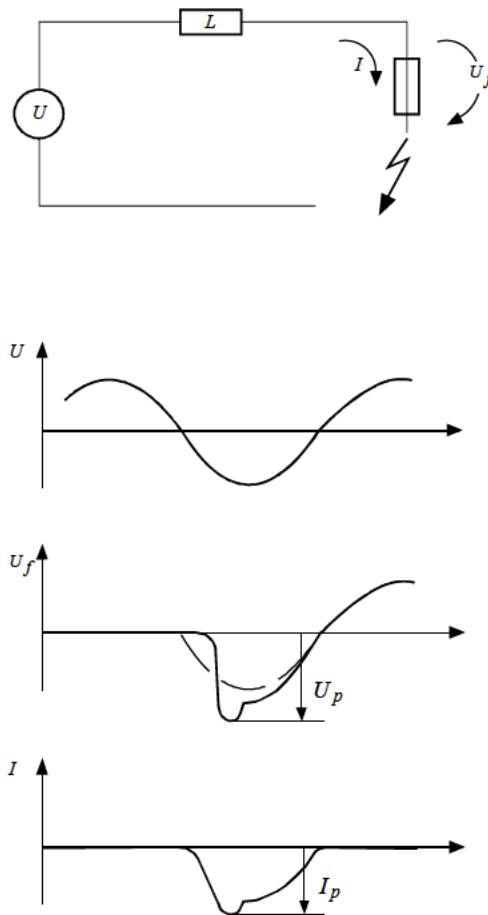
*Breaking phenomenon (see Figure 8-14):* when a short-circuit current occurs, the fuse element melts in a matter of milliseconds. An arcing voltage immediately occurs that is opposed to and higher than the supply voltage and therefore tends to reduce the current value. The fuse behaves like a variable resistance which, from being almost zero before fusion, increases to an infinite value when the current reaches zero causing the simultaneous modification of the current value and a phase displacement between this current and the supply voltage.

Two values are derived from this process:

- the maximum arcing voltage ( $U_p$ );
- the current  $I_p$ .

The maximum arcing voltage,  $U_p$ , or cut-off voltage, must be reduced in order to limit overvoltages on the network. The current  $I_p$ , which is the instantaneous short-circuit current actually flowing through the fuse, is called the cut-off current. It is lower than  $I_1$ . The parameters  $U_p$  and  $I_p$  are associated since a low  $I_p$  can be easily obtained with a high  $U_p$ .

The co-existence of a low  $I_p$  (limiting the thermal and electrodynamic effects downstream of the fuse) and a low  $U_p$  (limiting the overvoltages on the network during breaking) are proof that the design of MV fuses has been mastered.



**Figure 8-14:** maximum arcing voltage and cut-off current of an MV fuse

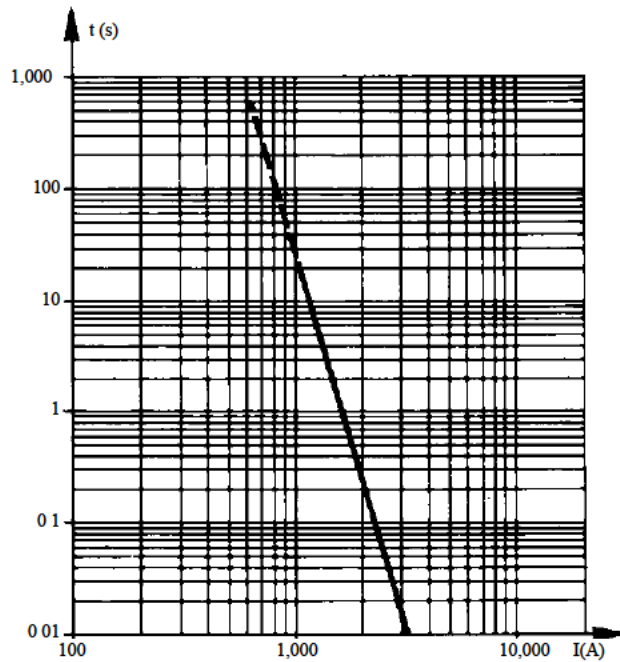
*Time/current characteristics of MV fuses:* a time/current curve is associated with each fuse. This curve gives the fusing or pre-arcing time in relation to the r.m.s. current (see Figure 8-15).

It is drawn on a logarithmic scale and can therefore be used to determine the pre-arcing time for each current value.

To obtain total operation, the arcing time must be added (5 to 50 ms).

The part of the curve drawn as a dotted line represents the pre-arcing or fusing time for currents lower than  $I_3$ .

This curve, which extends until it reaches a pre-arcing period of 600 seconds, is given with a  $\pm 10\%$  tolerance.



$I_3 = 1,000 \text{ A}$  in this figure

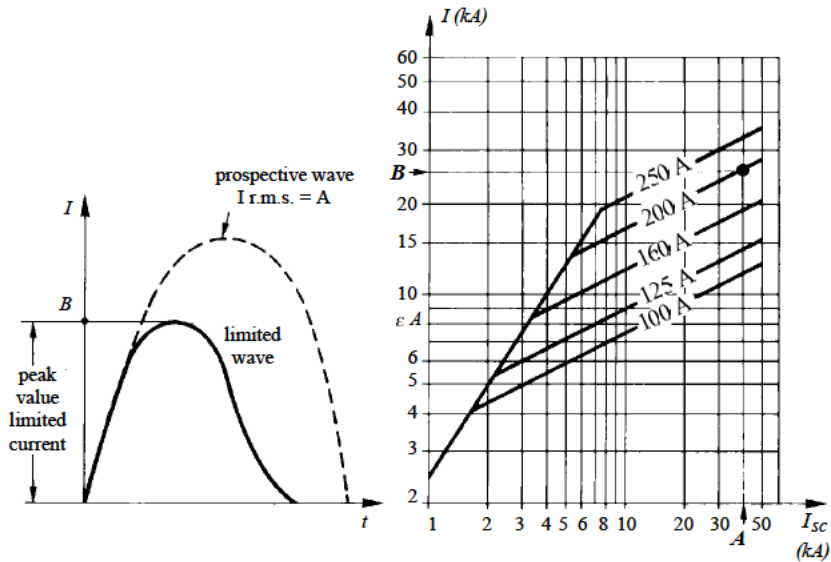
**Figure 8-15:** time/current characteristics of an MV fuse

*Characteristics of the cut-off current:* for current values close to  $I_1$  where the short-circuit current is limited, the curve in Figure 8-16 can be used to determine the  $I_p$  value of the limited current in relation to the prospective current.

*Example*

For a prospective short-circuit current of 40 kA (point A), the 200 A rated current fuse limits the short-circuit current to 25 kA (point B):

- the thermal effect (see section 5.2) is reduced by the ratio  $\frac{40}{25}=1.6$  ;
- the electrodynamic effect (see section 5.1) is reduced by the ratio  $\left(\frac{40}{25}\right)^2=2.6$  .



**Figure 8-16:** amplitude characteristics of the cut-off current

## Chapter 9

# Different Selectivity Systems

Protective devices form a coherent whole in relation to the network structure and its earthing system. They should be looked upon as a system based on the principle of selectivity that consists of isolating the part of the network affected by the fault, and only that part, as quickly as possible, while all the other unaffected parts of the network remain energized.

There are various ways of ensuring proper selectivity in electrical network protection:

- amperometric selectivity (using current);
- time-graded selectivity (using time);
- selectivity via information exchange, referred to as logic selectivity;
- selectivity via use of directional or differential protection.

### **9.1. Amperometric selectivity**

This is based on the fact that, within a network, the further the fault is from the source, the weaker the fault current.

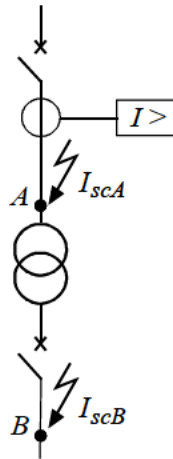
Amperometric protection is installed at the starting point of each section. Its threshold is set at a value lower than the minimum short-circuit current caused by a fault occurring on the monitored section, and higher than the maximum value of the current caused by a fault located downstream (beyond the monitored area).

Once set, each protection is only activated for faults located immediately downstream of its position (inside the monitored zone), and is insensitive to faults occurring beyond this point.

Nevertheless, in practice, it is difficult to define the settings of two cascading protection devices (while continuing to ensure proper selectivity), when the current does not notably decrease between two neighboring zones.

However, for line sections separated by a transformer, this system can be used advantageously as it is simple, economical and quick (tripping with no time delay).

The most interesting application example is the case where two line sections are separated by a transformer: see Figure 9-1.



**Figure 9-1:** two line sections separated by a transformer

The overcurrent protection is set at a threshold  $I_{set}$  such that:

$$I_{sc,max,B} < I_{set} < 0.8I_{sc2,min,A}$$

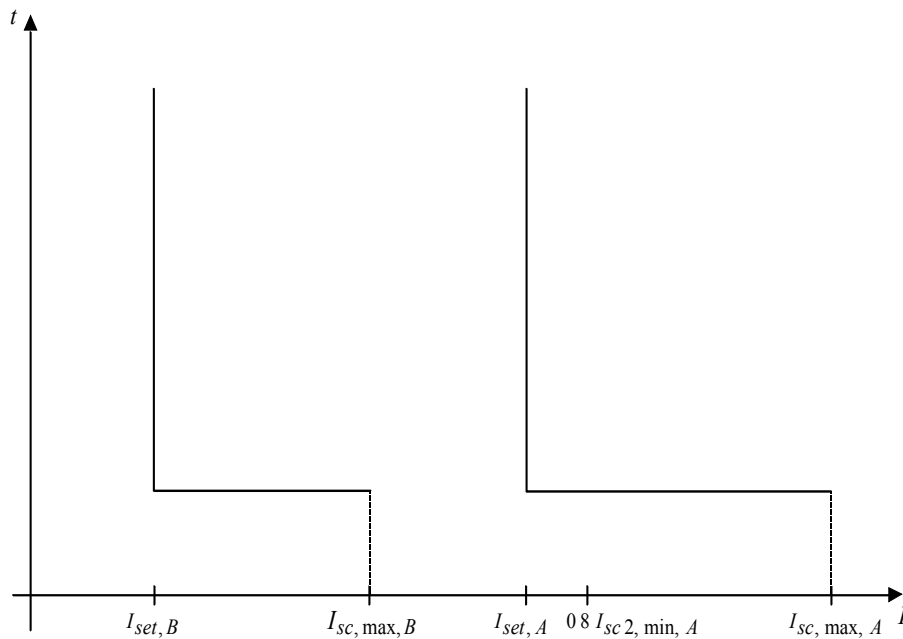
$I_{sc,max,B}$ : maximum short-circuit current at point B (this is generally the symmetrical three-phase short circuit: see section 4.2.1) recalculated for the upstream voltage level.

$I_{sc2,min,A}$ : minimum short-circuit current at point A (this is generally the phase-to-phase short circuit clear of earth: see section 4.4.2).

Due to the high impedance value of the transformer, the short-circuit current at B recalculated for the upstream voltage level (see section 4.2.1.1) is generally much lower than the short-circuit current at A.

This means that it is easy to meet the above condition.

Amperemetric protection is illustrated in Figure 9-2.



**Figure 9-2:** amperemetric selectivity between two line sections separated by a transformer

**Example**

Let us take a distribution network with a phase-to-phase voltage  $U_n = 20\text{ kV}$ , and a short-circuit power  $S_{sc} = 200\text{ MVA}$ .

This network feeds a 20 kV /410 V liquid-insulated transformer with a rated power of  $S_n = 2,000\text{ kVA}$ ; its short-circuit voltage is  $U_{sc} = 6.5\%$  (see Table 4-10):

- The impedance of the upstream network is  $Z_{up} = \frac{U_n^2}{S_{sc}}$  (see section 4.2.1.4).



$$I_{sc2, \min, A} = \frac{U_n}{2 Z_{up}} \quad (\text{see section 4.4.2})$$

hence:

$$I_{sc2, \min, A} = \frac{S_{sc}}{2 U_n} = \frac{200 \times 10^6}{2 \times 20 \times 10^3} = 5,000 \text{ A}$$

– The transformer impedance detected by the primary is:

$$Z_T = \frac{U_{sc}}{100} \frac{U_n}{S_n} \quad (\text{see section 4.2.1.4})$$

$$Z_T = \frac{0.065 \times (20 \times 10^3)^2}{2,000 \times 10^3}$$

$$Z_T = 13 \Omega$$

It is assumed that the resistances of the transformer and upstream network are negligible in relation to the reactances, and it is therefore possible to calculate the maximum short-circuit current at B as follows:

$$Z_{up} = \frac{U_n^2}{S_{sc}} = \frac{(20 \times 10^3)^2}{200 \times 10^6} = 2 \Omega$$

$$I_{sc, \max, B} = \frac{U_n}{\sqrt{3} (Z_A + Z_T)} \quad (\text{see section 4.2.1})$$

hence:

$$I_{sc, \max, B} = \frac{20 \times 10^3}{\sqrt{3} (2 + 13)} = 770 \text{ A}$$

The current setting threshold should be such that:

$$770 < I_{set} < 0.8 \times 5,000$$

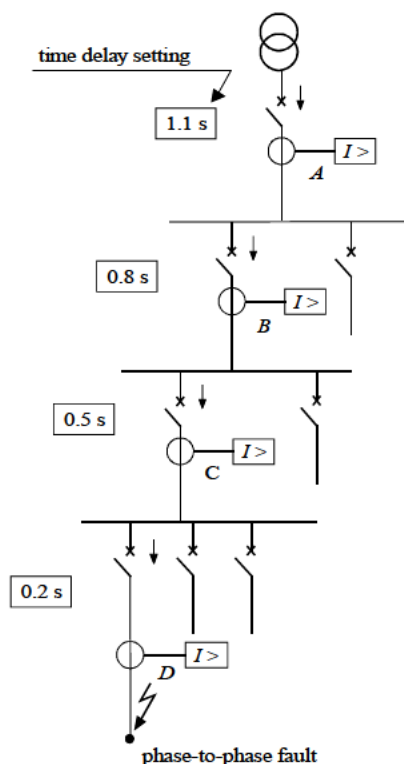
$$770 \text{ A} < I_{set} < 4,000 \text{ A}$$

Note: transformer protection is dealt with in section 10.3.4. Independent time double-threshold protection is used allowing tripping to be activated in the event of a fault occurring at the terminals downstream of the transformer or on the LV circuit-breaker. It is also activated in the event of the LV circuit-breaker failing.

**9.2. Time-graded selectivity**

This consists of setting different time delays for the overcurrent protection devices distributed throughout the network.

The closer the protection is to the source, the longer the time delay (see Figure 9-3a).



**Figure 9-3a:** *time-graded selectivity*

Thus, in Figure 9-3a, the fault shown is detected by all the protection devices (at A, B, C and D). The time-delayed protection at D closes its contacts more quickly than the one installed at C, which in turn reacts more quickly than the one located at B.

Once circuit-breaker D has been tripped and the fault current has been cleared, protection devices A, B and C, through which the current no longer passes, return to stand-by position.

The protection devices are activated when the current rises above the pre-defined setting.

The threshold settings must therefore be coherent.

The difference in operating times  $\Delta t$  between two successive protection devices is the *selectivity interval*. It takes into account:

- circuit-breaker breaking time  $t_c$ ;
- time delay tolerances  $\delta t$ ;
- upstream protection memory time  $t_m$ ;
- a safety margin.

$\Delta t$  must therefore satisfy the relation:

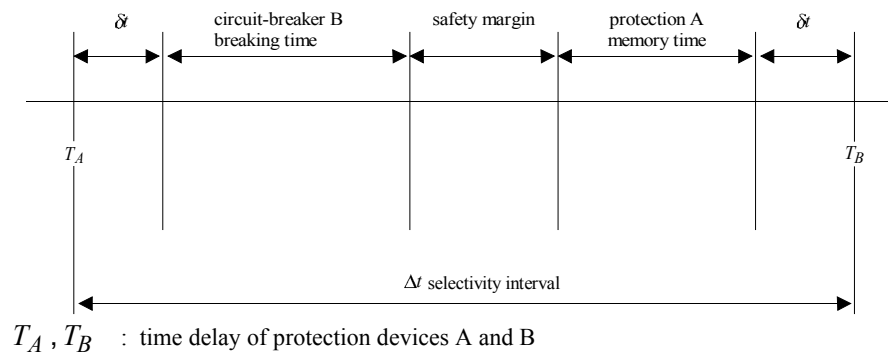
$$\Delta t \geq t_c + t_m + 2\delta t + \text{margin} \quad (\text{see Figure 9-3b})$$

Taking into account the present performances of switchgear and protection devices,  $\Delta t$  is assigned a value of 0.3 seconds (after detailed examination it is sometimes possible to take 0.25 seconds).

For example, for the independent time phase overcurrent protection devices of the Sepam 2000 associated with Fluarc FG1 circuit-breakers (see Figure 9-3b):

$t_c = 85 \text{ ms}$		
$t_m = 55 \text{ ms}$		maximum values
$\delta t = 25 \text{ ms}$		

For a selectivity interval  $\Delta t = 0.3 \text{ s}$ , the safety margin is 110 ms.



**Figure 9-3b:** *selectivity interval*

This selectivity system has two advantages:

- it provides its own back-up. Indeed, the protection at C will be activated if the protection at D fails (a healthy part of the installation is cut off);
- it is simple.

However, when there are a large number of cascading relays, the fault clearing time is prohibitive and incompatible with the short-circuit current withstand of equipment, or with outside operating requirements, owing to the fact that the protection furthest upstream has the longest time delay (see section 10.1.3).

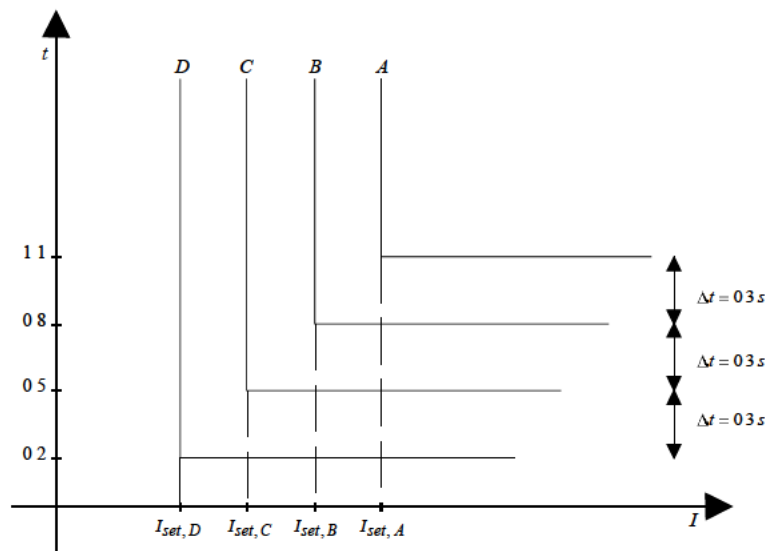
Thus, the highest fault current is cleared after the longest time delay.

Both types of overcurrent protection (independent and inverse time) can be used.

***Time-graded selectivity with independent time overcurrent protection***

The protection time delay is constant and independent of the current (see section 7.1).

The protection tripping curves are shown in Figure 9-4.



**Figure 9-4:** time-graded selectivity with independent time overcurrent protection

The current threshold settings must be such that:

- $I_{set,A} > I_{set,B} > I_{set,C} > I_{set,D}$

–  $I_{set,A}$ ,  $I_{set,B}$ ,  $I_{set,C}$ ,  $I_{set,D}$ : current thresholds of protection devices  $A$ ,  $B$ ,  $C$  and  $D$ .

It is estimated that the accuracy of the measuring unit is 10%.

Two successive protection devices must therefore comply with the following relation:

$$0.9 I_{set,A} > 1.1 I_{set,B}$$

i.e.

$$I_{set,A} \geq 1.22 I_{set,B}$$

In practice, the following values are taken:

$$I_{set,A} \geq 1.25 I_{set,B}$$

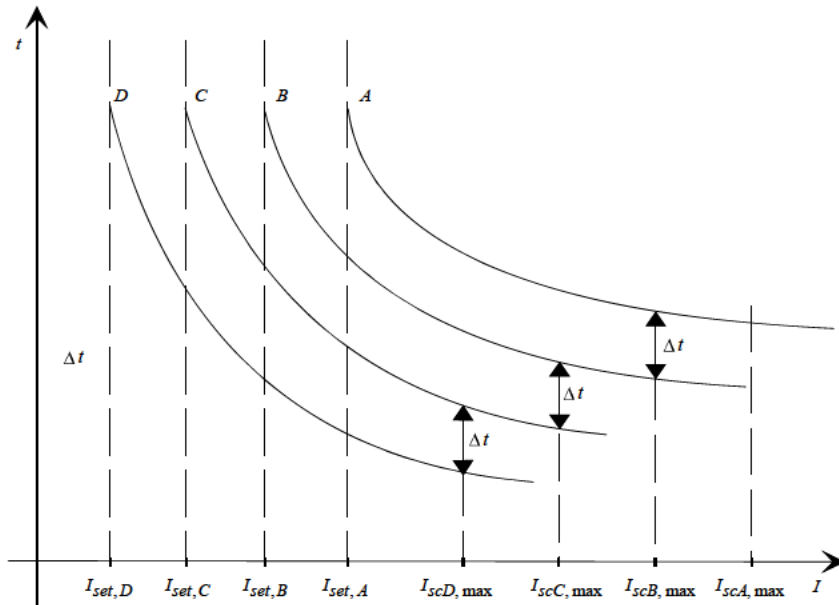
$$I_{set,B} \geq 1.25 I_{set,C}$$

$$I_{set,C} \geq 1.25 I_{set,D}$$

**Time-graded selectivity with inverse time overcurrent protection**

The greater the current, the shorter the time delay (see section 7.2).

The protection tripping curves are shown in Figure 9-5.



**Figure 9-5:** time-graded selectivity with inverse time overcurrent protection

If the current thresholds are set at a value close to  $I_n$ , both protection against overloads and protection against short circuits are ensured. The following values are, for example, taken:

$$-I_{set,A} = 1.2 I_{nA}, I_{set,B} = 1.2 I_{nB}, I_{set,C} = 1.2 I_{nC} \text{ and } I_{set,D} = 1.2 I_{nD}$$

-  $I_{nA}, I_{nB}, I_{nC}, I_{nD}$ : nominal currents at the location points of protection devices  $A, B, C$  and  $D$

To ensure selectivity, the protection devices must satisfy the following two conditions:

- The current threshold must be set to at least 25% above the downstream protection threshold:

$$I_{set,A} \geq 1.25 I_{set,B}, I_{set,B} \geq 1.25 I_{set,C}, I_{set,C} \geq 1.25 I_{set,D}.$$

- The time delay settings are determined in order to obtain the selectivity intervals  $\Delta t = 0.3 \text{ s}$  for the maximum current detected by the downstream protection. For example, for the maximum short circuit at  $D$ , the time delay at  $C$  must be longer than the time delay at  $D$  by a value  $\Delta t$ .

### 9.3. Logic selectivity

As we have just seen, amperometric and time-graded selectivities have their weaknesses.

The logic selectivity system has been designed to eliminate these drawbacks. With this system, perfect selectivity can be obtained when tripping occurs and, furthermore, the tripping time delay of the circuit-breakers located closest to the source is reduced considerably.

When a fault occurs in a radial network, the fault current flows through the circuit located between the source and the fault point:

- a current flows through the protection devices upstream of the fault;
- a current does not flow through the protection devices downstream of the fault;
- only the first protection directly upstream of the fault must be activated.

A protective device able to send and receive a logic standby order is associated with each circuit-breaker. When a fault current flows through the protection, the latter:

- sends a logic standby order to the protection directly upstream;
- causes tripping of the associated circuit-breaker if it has not received a logic standby order from another protection.

Figure 9-6 gives a simplified description of a radial distribution system.

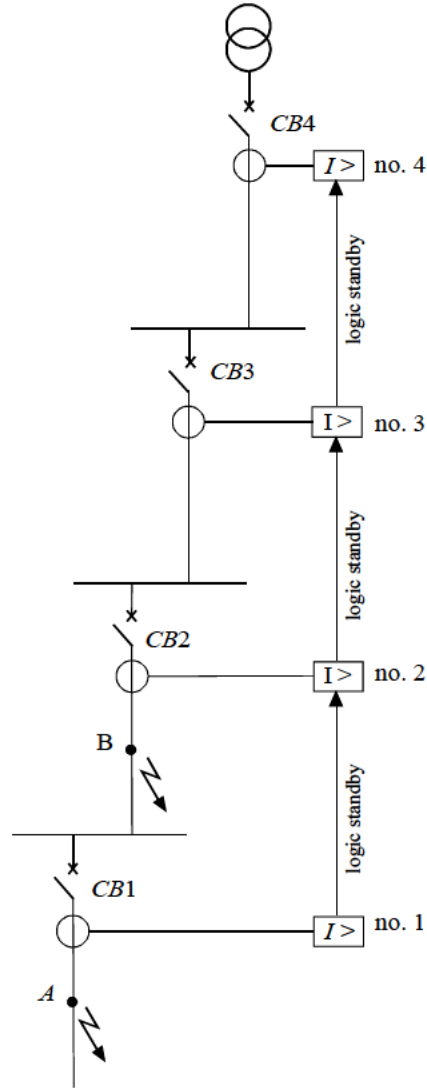


Figure 9-6: logic selectivity

**Operation when a fault occurs at A**

A fault current flows through protection devices no. 1, no. 2, no. 3 and no. 4.

Protection no. 1 sends a logic standby order to upstream protection no. 2 and a tripping order to circuit-breaker CB1.

Protection no. 2 sends a logic standby order to upstream protection no. 3 and receives the logic standby order from protection no. 1, which locks the tripping order of circuit-breaker CB2.

Protection no. 3 sends a logic standby order to upstream protection no. 4 and receives the logic standby order from protection no. 2, which locks the tripping order of circuit-breaker CB3.

Protection no. 4 receives the logic standby order from protection no. 3, which locks the tripping order of circuit-breaker CB4.

Circuit-breaker CB1 clears the fault at A at the end of a time interval:

$$t_{CB1} = t1 + t_{c, CB1}$$

$t1$  : protection no. 1 time delay

$t_{c, CB1}$  : circuit-breaker CB1 breaking time

#### ***Operation when a fault occurs at B***

- a fault current flows through protection no. 1;
- a fault current flows through protection devices no. 2 and no. 3, which then send a logic standby order upstream;
- only protection no. 2 does not receive a logic standby order and sends a tripping order to circuit-breaker CB2.

Circuit-breaker CB2 clears the fault at B at the end of a time interval:

$$t_{CB2} = t2 + t_{c, CB2}$$

$t2$  : protection no. 2 time delay

$t_{c, CB2}$  : circuit-breaker CB2 breaking time

Time delays  $t1$ ,  $t2$ ,  $t3$  and  $t4$  of protection devices no. 1, no. 2, no. 3 and no. 4 are not involved in the selectivity and are only used to provide protection. The settings can be as short as logic standby order transmission and reception time allows, i.e. 0.1 to 0.2 seconds depending on the equipment.

With the logic selectivity system, the fault clearance time can be reduced and is independent of the number of stages. It is possible to obtain selectivity between an upstream protection with a short time delay and a downstream protection with a long time delay, e.g. by setting a shorter time delay at the source than near the loads.

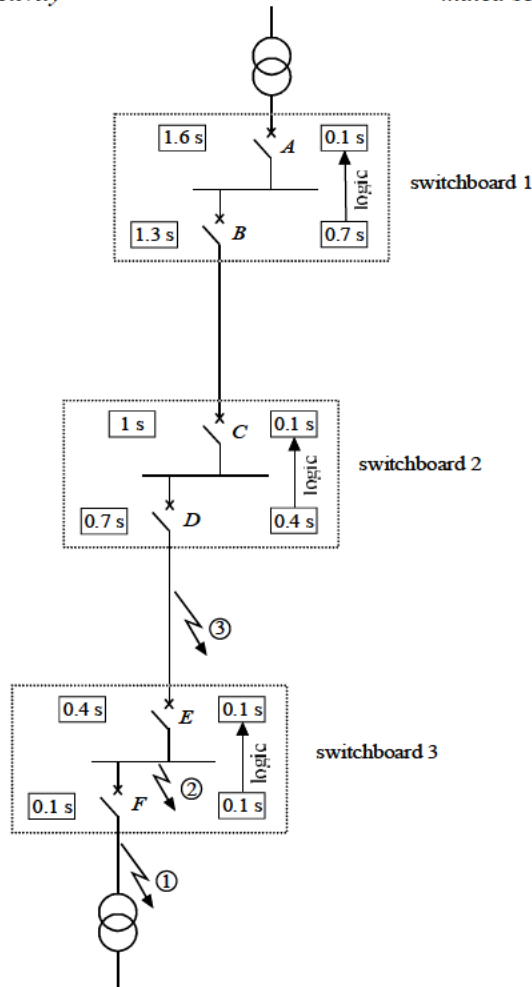


Note: to ensure safety, the logic standby time is limited, thus allowing an upstream protection to operate as back-up of a faulty downstream protection.

**Example: mixed selectivity (logic + time-graded) (see Figure 9-7)**

*time-graded selectivity*

*mixed selectivity*



**Figure 9-7: mixed selectivity**

*Operation of mixed selectivity*

Logic selectivity is set up between the incoming feeder and the outgoing feeders of each switchboard.

The logic link wire costs little since it connects the circuit-breakers or relays to the same switchboard.

Between the switchboards, time-graded selectivity is set up, thus avoiding the necessity of installing long logic link wires.

The logic standby time is limited to 200 ms after the time delay of the protection giving the standby order. This allows the protection upstream to operate as back-up for a faulty downstream protection.

#### *Fault at ①*

The protection devices at F, D and B send a logic standby order to protection devices E, C and A, which may be time delayed to 0.1 second, respectively.

The circuit-breaker F is tripped after its time delay of 0.1 second.

The non-tripping of circuit-breakers D and B is ensured by time-graded selectivity:  $t_D = t_F + 0.3 \text{ s}$  and  $t_B = t_D + 0.3 \text{ s}$ .

In the event of failure of the protection at F or the associated circuit-breaker, the protection at E is activated after the logic standby time, i.e.  $0.1 + 0.2 = 0.3$  seconds. The 0.4 second time-delayed protection at D is also activated (there is no selectivity between E and D in the event of F failing, unless D's time delay is increased).

#### *Fault at ②*

The protection devices at D and B send a logic standby order to the protection devices at C and A respectively.

The circuit-breaker E is tripped after its time delay of 0.1 second.

#### *Fault at ③*

The protection devices at D and B send a logic standby order to the protection devices at C and A respectively.

The circuit-breaker at D is tripped after its time delay of 0.4 seconds.

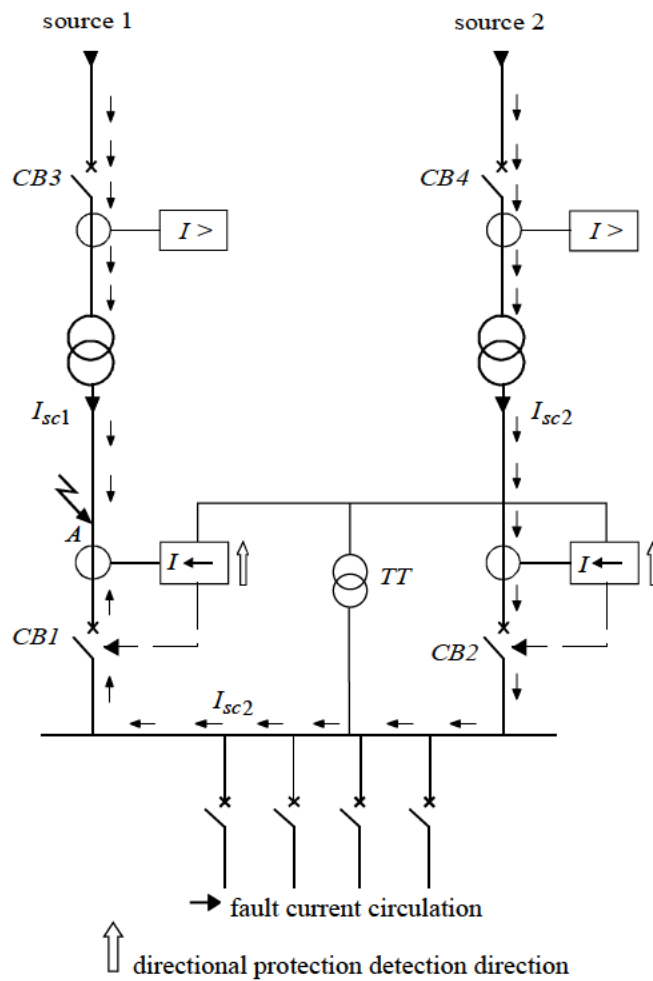
In the event of failure of the protection at D or the associated circuit-breaker, the protection at C is activated after the logic standby time, i.e.  $0.4 + 0.2 = 0.6$  seconds.

Therefore, using mixed selectivity the time delays can be reduced (roughly by a ratio of 2) without going to great expense, since logic link wires need only be installed between circuit-breakers or relays in the same switchboard.

**9.4. Directional selectivity**

In a meshed network, in which a fault is fed by both ends, protection that is sensitive to the direction of the fault current flow must be used in order to be able to locate and clear the fault. To do this, directional overcurrent protection devices are used (see sections 7.3 and 7.4).

We will give an example of directional selectivity for the phase-to-phase faults in a network with two incoming feeders (see Figure 9-8).



**Figure 9-8:** directional selectivity for the phase-to-phase faults in a network with two parallel incoming feeders

Circuit-breakers CB1 and CB2 are fitted with directional overcurrent protection devices, whereas CB3 and CB4 are fitted with phase overcurrent protection devices.

For a fault at A:

- the short-circuit currents  $I_{sc1}$  and  $I_{sc2}$  are established simultaneously;
- the directional protection at CB2 is not activated because a current circulating in the opposite direction to its protection detection flows through it;
- the directional protection at CB1 is activated because a current circulating in the same direction as its protection detection flows through it. This causes the circuit-breaker CB1 to be tripped and the current  $I_{sc2}$  is interrupted. An inter-tripping system causes CB3 to open and the current  $I_{sc1}$  is interrupted;
- the protection at CB4 is no longer activated.

The selectivity between the directional protection at CB1 and the protection at CB4 is time-graded.

Similarly, the selectivity between the directional protection at CB2 and the protection at CB3 is time-graded.

For further details about the protection of a network with two parallel incoming feeders, see section 10.1.5.

### 9.5. Selectivity by differential protection

This type of protection compares the currents at the ends of the monitored network section (see Figure 9-9). Any difference between these currents indicates the presence of a fault. The protection reacts only to faults inside the monitored zone and is insensitive to any external fault. It is thus self-selective.

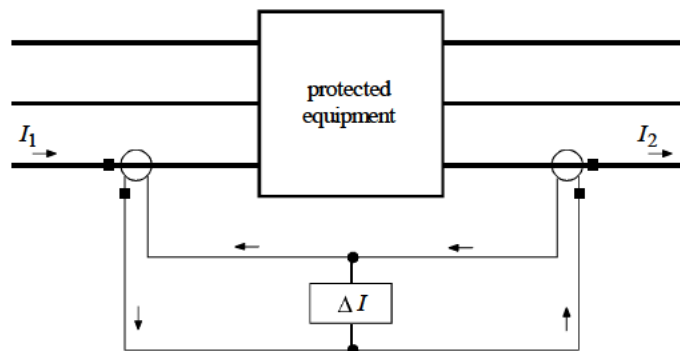


Figure 9-9: selectivity by differential protection

The equipment protected may be:

- a motor;
- a generator;
- a busbar;
- a cable or line;
- a transformer.

This type of protection has the following characteristics:

- it can detect fault currents lower than the nominal current;
- the time delay may be short, if not zero, since the selectivity is based on the detection and not on the time delay.

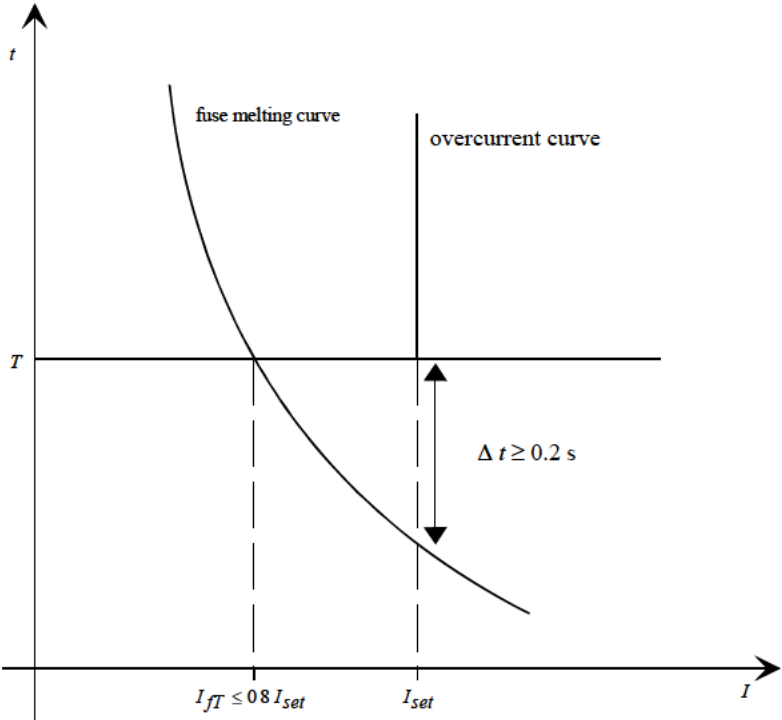
A detailed explanation of differential protection operation is given in section 7.6.

#### **9.6. Selectivity between fuses and circuit-breakers**

There are two different selectivity problems, depending on whether the fuse is located upstream or downstream of the circuit-breaker.

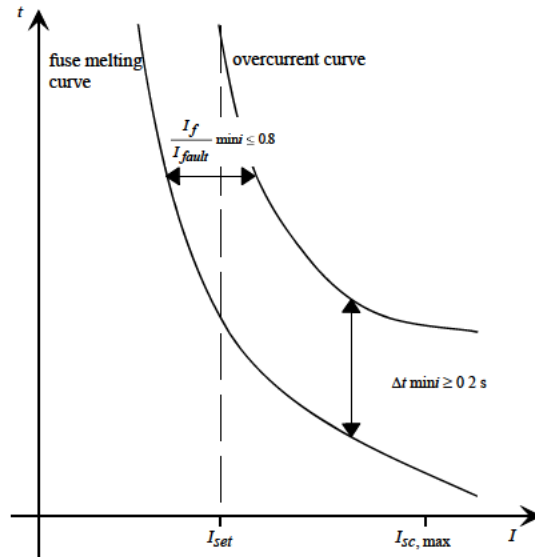
##### ***Fuse downstream of a circuit-breaker***

Let us consider an MV fuse and an MV circuit-breaker fitted with an overcurrent protection. The operating curves must meet the conditions shown in Figure 9-10 for an independent time protection or those in Figure 9-11 for an inverse time protection.



$T$  : protection time delay  
 $I_{set}$  : protection setting threshold  
 $I_{fT}$  : current value for which the fuse interrupts the current in time  $T$

Figure 9-10: selectivity between fuse and independent time protection



- $I_f$  : fusing current of fuse
- $I_{fault}$  : current activating threshold
- $\frac{I_f}{I_{fault}} \text{ mini}$  : point at which the fuse's fusing current is closest to the current activating protection (between  $I_{set}$  and  $I_{sc,max}$ )
- $\Delta t \text{ mini}$  : point at which the difference between the protection activation time and the fuse's fusing time is at its minimum (between  $I_{set}$  and  $I_{sc,max}$ )
- $I_{sc,max}$  : maximum short-circuit current at the downstream terminals of the fuse
- $I_{set}$  : protection setting threshold

Figure 9-11: selectivity between fuse and inverse time protection

**Fuse upstream of a circuit-breaker**

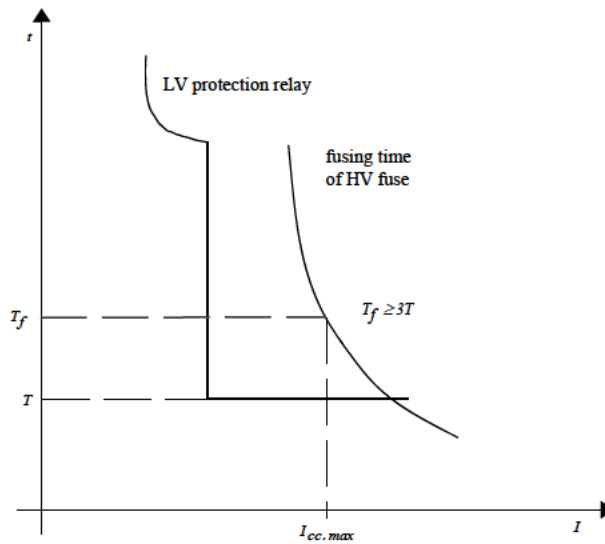
This is the case for a transformer between the upstream protection switch-fuse and the circuit-breakers of the LV switchboard located immediately downstream.

Standard IEC 62271-105 concerning switch-fuse combinations stipulates that the three-phase short-circuit current at the secondary terminals of the transformer must cause the fuses to blow in a time less than the switch opening time caused by the fuses (40 ms – 10% = 36 ms for the SM6, see section 10.3.4.3.1).

As a result, for low voltage short circuits occurring near the transformer, the fusing time is less than roughly 36 ms. It is thus not possible to obtain selectivity between circuit-breakers of main switchgear downstream of the transformer and the upstream fuse.

If LV circuit-breakers are delayed, only those located far enough from the transformer can be selective with the fuse. Indeed, the short-circuit current is then low enough so that fusing time is higher than time delay. In order that selectivity is total and without any risk of fuse damaging, fusing time must be higher than three times the circuit-breaker time delay for the maximal short-circuit at the terminals (see Figure 9-12).

The non-selectivity of fuse with LV circuit-breakers near the transformer is an important disadvantage compared to the solution with MV circuit-breaker protection (see section 10.3.4.3.2).



$I_{sc,max}$  : maximal short-circuit current detected by circuit-breaker

$T$  : circuit-breaker time delay

$T_f$  : fusing time for  $I_{sc,max}$

**Figure 9-12:** Selectivity between MV fuse upstream of a circuit-breaker





## Chapter 10

# Protection of Network Elements

### 10.1. Network protection

#### *Notations*

$\Delta t$  : selectivity interval (generally set at 0.3 seconds: see section 9.2)

$I_{setA}$  : current threshold of the protection located at A (“A” for arrival)

$I_{setDi}$  : current threshold of the protection located on the outgoing feeder  $Di$  (“D” for departure)

$I_{sc2,min,A}$  : minimum phase-to-phase short-circuit current with protection located at A

$I_{sc2,min,Di}$  : minimum phase-to-phase short-circuit current with protection located on the outgoing feeder  $Di$

$I_\ell$  : resistance limited current

$I_C$  : total capacitive current of the network when a phase-to-earth fault occurs,

$$I_C = \left( \sum_q C_q \right) 3j\omega V_n$$

$I_{Ci}$  : capacitive current generated by the outgoing feeder  $Di$  when a phase-to-earth current occurs,  $I_{Ci} = 3jC_i\omega V_n$

$I_p$  : permanent current that the earthing resistor can withstand

$I_{nCT}$  : current transformer rating

$t_H$  : time delay of the protection located at  $H$ ,  $H1$  or  $H2$

$t_A$  : time delay of the protection located at  $A$ ,  $A1$  or  $A2$

$t_D$  : time delay of the protection located on the outgoing feeders  $Di$

$t_N$  : time delay of the protection located on the neutral earthing connection

$V_{set,A}$  : threshold of the residual overvoltage protection that trips the circuit-breaker at  $A$ ,  $A1$  or  $A2$

$t_R$  : directional protection time delay

$I_{set,R}$  : directional protection current threshold

We will first of all determine the requirements of the network and equipment for earth faults relevant to the earthing system, and then we will examine the requirements for phase-to-phase faults.

**10.1.1. Earth fault requirements for networks earthed via a limiting resistance (directly or by using an artificial neutral)**

*Transient overvoltages occurring during phase-to-earth fault clearance by a circuit-breaker*

Phase-to-earth fault clearance or successive arcing causes overvoltages to occur on the network that may lead to breakdown in equipment insulators.

Experience has shown that when the condition

$$I_\ell > 2 I_C$$

$I_\ell$  : resistance limited current

$I_C$  : total capacitive current of the network

is met, the transient overvoltage does not exceed 240% of the peak value of the nominal single-phase voltage. It is difficult to obtain a transient overvoltage below 240% even if the limiting current is increased.

Efforts should always be made to meet the above condition.

Furthermore, this condition facilitates detection and location of an earth fault.

***Limiting earth fault currents in rotating machines***

So that rotating machines are not damaged when an earth fault occurs, the resistance limited current  $I_\ell$  should satisfy the following condition:

$$I_\ell < 20 \text{ to } 30 \text{ A}$$

***Detection of internal phase-frame faults of three-phase machines***

When an insulation fault occurs between the winding of a machine (transformer, generator or motor) and the frame, the fault current value depends on the fault position in relation to the neutral point and the winding connection.

*Star-connected windings (see Figure 10-1)*

Before a fault occurs, the voltage between any point in a winding and the earth is equal to  $xV$ , where  $x$  is between 0 and 1, characterizing the position of the fault in the winding, and  $V$  is a single-phase voltage.

When a fault occurs at a distance  $x$  from the neutral point, the fault current value is:

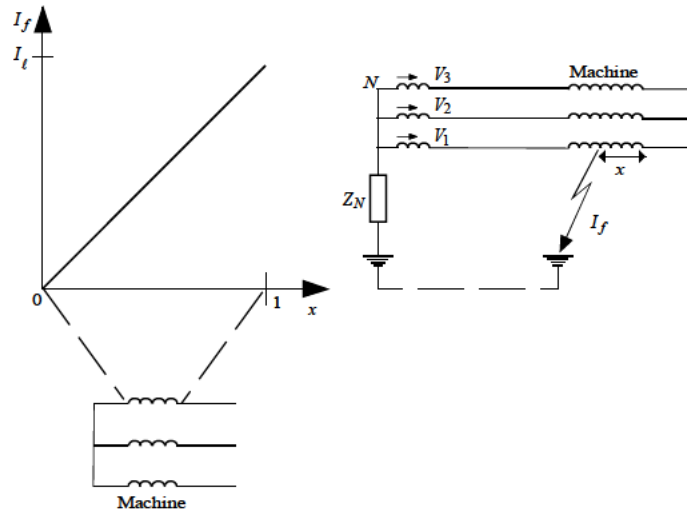
$$I_f = \frac{xV}{Z_N} \text{ for a solid fault.}$$

The impedances of the machine and links are negligible in relation to the earthing impedance.

Thus:

$$I_f = x I_\ell.$$

The current is therefore zero when the fault occurs at the neutral point ( $x = 0$ ) and at its maximum value when the fault occurs at the machine terminals ( $x = 1$ ).



**Figure 10-1:** fault current in relation to the position of the fault on the winding for a star-connected machine

**Delta-connected windings (see Figure 10-2)**

The voltage that exists between a winding and earth before the fault occurs is shown to be at its minimum at the mid-point of the winding, being equal to a value of  $\frac{V}{2}$  where  $V$  is the network single-phase voltage. Indeed, the voltage in relation to earth at the mid-point of the winding between phases 1 and 3 is equal to:

$$V_m = V_1 + \frac{V_3 - V_1}{2}$$

$$V_m = \frac{V_1}{2} + \frac{a V_1}{2} \quad \text{since } V_3 = a V_1 \text{ where } a = e^{\frac{2j\pi}{3}}$$

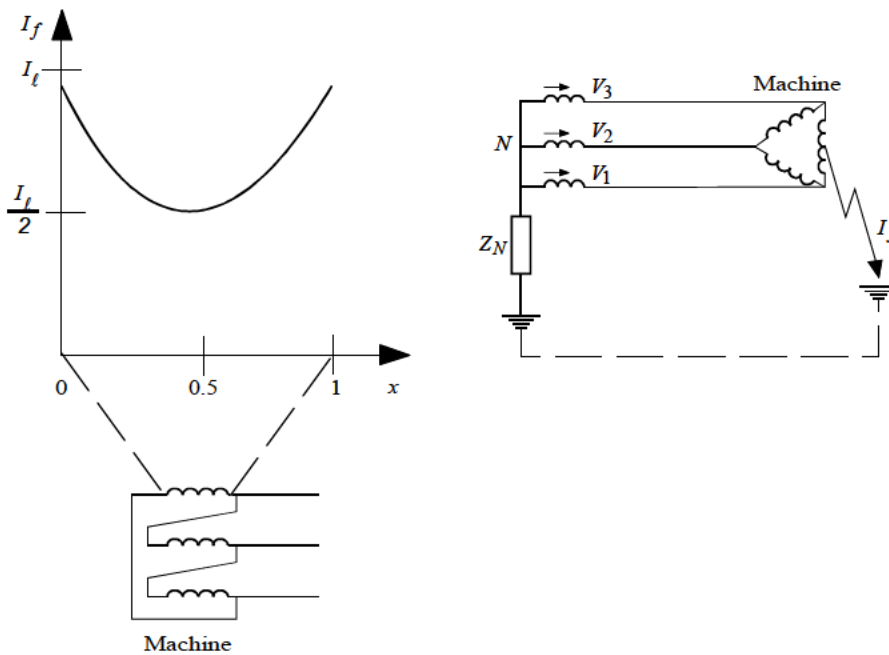
$$V_m = -\frac{a^2 V_1}{2} \quad \text{since } 1 + a + a^2 = 0$$

$$|V_m| = \left| \frac{V_1}{2} \right| \text{ since } |a^2| = 1$$

When a fault occurs at the mid-point of a winding, the fault current value is  $I_f = \frac{V}{2 Z_N}$  for a solid fault (the impedances of the machine and links are negligible in relation to the earthing impedance).

Thus:

$$I_f = \frac{I_\ell}{2}$$



**Figure 10-2:** fault current in relation to the position of the fault on the winding for a delta-connected machine

When an insulation fault occurs inside a machine, the fault current may be much lower than the limiting current  $I_\ell$  obtained for a phase-to-earth solid fault in the network; it is close to zero for a fault occurring near the neutral point of a star-connected machine. It is very difficult to detect this type of fault and it is therefore not possible to protect all the windings of a star-connected machine using earth fault protection.

For example, setting the earth fault protection at  $0.1 I_\ell$  provides 90% protection for the windings for a star-connected machine and 100% protection for the windings for a delta-connected machine.

**Selectivity between outgoing feeders**

In section 4.3 we saw that when an earth fault occurs:

– the residual current value of the faulty outgoing feeder is:

$$I_f = \frac{V_n}{Z_N} + 3j(C - C_f)\omega V_n$$

$C$  : total network capacitance

$C_f$  : faulty outgoing feeder capacitance

– the capacitive current value of a healthy feeder is:

$$I_{Ci} = 3j C_i \omega V_n$$

$C_i$  : capacitance of the  $i^{\text{th}}$  healthy feeder

In order not to cause spurious tripping, the current threshold setting  $I_{set,Di}$  of the earth fault protection must be set at a value higher than  $I_{Ci}$ .

To ensure a safety margin, the following condition must be met:

$$I_{set,Di} \geq 1.3 I_{Ci}.$$

When the capacitive currents are high and the network requirements do not allow this condition to be met, directional earth fault protection devices are used (see section 7.4.2) because they allow a fault current to be distinguished from the capacitive current of a healthy feeder.

**Selectivity with downstream protection**

The outgoing feeder protection must be compatible with the downstream protection devices. If the time delay required is too long, logic selectivity must be used (see section 9.3).

**Selectivity with the utility power supply**

The maximum time delay at the consumer substation may be stipulated by the utility. For example, in France, EDF (the French electricity authority), stipulates a time delay less than or equal to 0.2 seconds, which means that time-graded selectivity using a circuit-breaker located downstream cannot be used. Logic or differential selectivity must be used when the network is made up of several stages.

**Protection tripping**

To ensure earth fault protection tripping, the protection current threshold must be lower than the current limited by the earthing resistor.

To ensure a safety margin, the following condition must be met:

$$I_{set} \leq 0.8I_{\ell}$$

#### ***Dimensioning the earthing resistor***

The earthing resistor must withstand:

- the permanent current  $I_p$  that flows through it. This current may be caused by an impedant fault or by a slight displacement of the neutral point due to an unbalance in the capacitances of the network's three phases. A permanent current withstand  $I_p = \frac{I_{\ell}}{10}$  is generally selected.

- the limiting current for the maximum fault clearance time. The resistor is usually required to withstand the current  $I_{\ell}$  for 2 to 5 seconds so that eventual reclosings may take place upon occurrence of a fault.

#### ***Earthing resistor protection***

The protection located on the neutral earthing connection (see Figure 10-5a) ensures protection against network faults and also provides earthing resistor protection. If the current threshold of this protection is higher than the permanent current  $I_p$  that the resistor can withstand, a fault current that is between these two values may damage the resistor. In this case, it is necessary to add a second protection threshold, which must be lower than  $I_p$  and be time-delayed by several seconds.

#### ***Minimum threshold setting of earth protection***

There is a risk of spurious tripping of the protection due to measurement error of the residual current, specifically in the presence of transient currents.

In order to prevent this risk, protection setting must be above:

- approximately 12% of the nominal rating  $I_{nCT}$  of the CTs when measurement is carried out using three current transformers (see Figure 7-7). The condition  $I_{set} \geq 0.12I_{nCT}$  must thus be met. *Example:* for a 100/5 A CT the condition is  $I_{set} \geq 12A$ .

- 1A for a time delay of 0.1 second when measurement is carried out using a core balance (see Figure 7-6). If exceptional installation precautions are used, it is possible to have a setting threshold lower than 1A.

#### ***Thermal withstand of cable shields***

The limiting current  $I_{\ell}$  must be lower than the maximum overcurrent that the cable shields can withstand for the duration of the maximum fault clearance time.



For example, the short-time withstand current allowable in a SPIRELEC 20 kV 240 mm<sup>2</sup> cable shield is 2,400A for 1 second.

**Summary of earth fault requirements for networks with limiting resistance earthing (see Table 10-1)**

Causes	Requirements
Limitation of transient overvoltages	$I_{\ell} > 2I_C$
Limitation of rotating machine earth fault currents	$I_{\ell} < 20$ to $30 A$
Detection of machine phase-frame internal faults	$I_{set,Di} = 0.1 I_{\ell}$ for star-connection $I_{set,Di} \leq 0.5 I_{\ell}$ for delta-connection
Selectivity between outgoing feeders	$I_{set,Di} \geq 1.3 I_{Ci}$ when protection is not directional
Selectivity with downstream protection	If the time delay required is too great, use logic selectivity
Selectivity with the utility power supply	Time delay $\leq$ maximum time delay stipulated by the utility
Protection tripping	$I_{set} \leq 0.8 I_{\ell}$
Earthing resistor dimensioning	Permanent withstand: $I_p = \frac{I_{\ell}}{10}$ Short-time withstand: $I_{\ell}$ for 2 to 5 seconds
Earthing resistor protection via the protection located on the neutral earthing connection	Threshold $< I_p$ Time delay of several seconds
Minimum threshold setting of earth protection	– $I_{set} \geq 0.12 I_{nCT}$ for measurement by 3 CTs – $I_{set} \geq 1 A$ and time delay $\geq 0.1 s$ for measurement by torroid
Thermal withstand of cable shields	$I_{\ell} <$ overcurrent allowed by shields

**Table 10-1:** earth fault requirements for networks with limiting resistance earthing (direct or via an artificial neutral)

### 10.1.2. Earth fault requirement for unearthed networks

#### *Transient overvoltages occurring during phase-to-earth fault clearance by a circuit-breaker*

The risk of overvoltages occurring is high and it is therefore advisable to reinforce equipment insulation.

#### *Earth fault currents in rotating machines*

These are due to the network capacitive currents.

They must not be too great, if possible, so that the rotating machines are not damaged, i.e. they must be less than 20–30A.

When the network is being designed, capacitive currents can be limited by breaking up the network using several transformers.

#### *Selectivity with downstream protection*

The protection of outgoing feeders must be compatible with the downstream protection devices. If the time delay required is too high, logic selectivity must be used (see section 9.3).

#### *Selectivity between outgoing feeders*

In section 4.3 we saw that when an earth fault occurs:

– the capacitive current value of a healthy outgoing feeder is:

$$I_{Ci} = 3jC_i\omega V_n$$

– the current value of the faulty feeder is:

$$I_f = 3j(C - C_f)\omega V_n$$

$C$  : total network capacitance

$C_f$  : capacitance of the faulty feeder

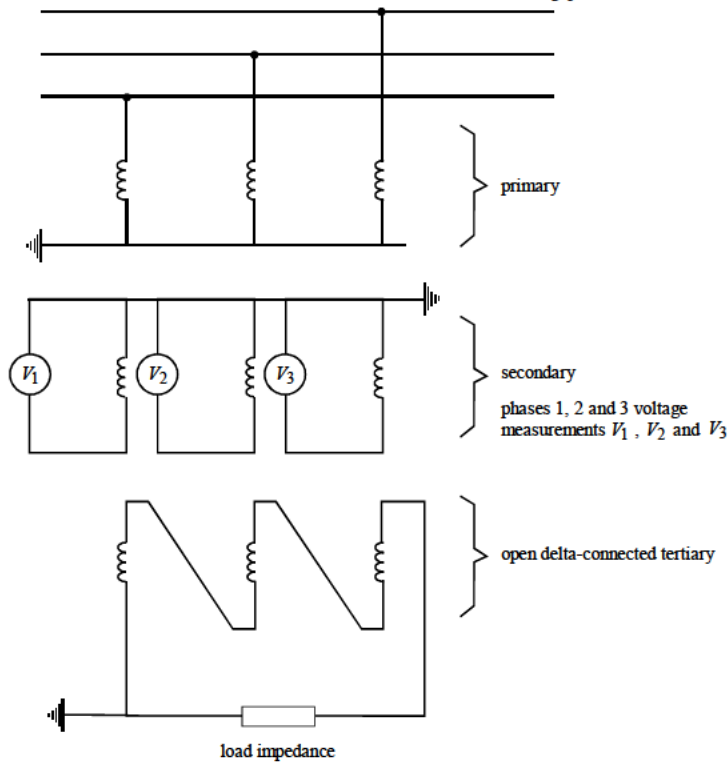
To avoid spurious tripping, the outgoing feeders must be fitted with directional earth fault protection (see section 7.4.3), which allows the capacitive current of a healthy feeder to be distinguished from the capacitive current of a faulty feeder.

#### *Limiting the risk of ferro-resonance*

The voltage transformer secondaries must be loaded via an impedance (see Figures 2-13 and 2-14) to dampen ferro-resonant phenomena that may appear with a phase-to-earth overvoltage. The value of the resistance must be weak enough to be effective. However, it must not be too weak so that VT are not overloaded and

their accuracy is preserved. A resistance value of  $68\Omega$  is recommended for a secondary voltage of  $\frac{100}{\sqrt{3}} V$ .

Another solution consists of using voltage transformers with three windings, the tertiary being used particularly for the VT load. Ferro-resonance occurs when there is a voltage displacement, which is why the tertiary is open delta-connected and loaded via the impedance (see Figure 10-3). There is no current in the impedance during normal operating conditions. Nevertheless, with phase-to-earth overvoltage, a current circulates in the load impedance, thus dampening, ferro-resonant phenomena. Experience has shown that it is necessary to dissipate a power higher than 50 W in the resistor upon an earth fault. For a tertiary voltage of  $\frac{100}{3} V$ , in case of a solid earth fault, the voltage at resistor terminals is equal to 100 V (see section 7.4). We can then determine resistance value:  $R \leq \frac{100^2}{50}$  hence  $R \leq 200\Omega$ .



**Figure 10-3:** voltage transformer with three windings and loaded tertiary to dampen ferro-resonant phenomena

**Minimum threshold setting of earth protection**

The measurement must be made using a torroid since the value of the fault currents is low (only capacitive currents). To avoid any spurious tripping due to false transient residual currents, the protection must satisfy the following conditions:

$$I_{set} \geq 1A$$

time delay  $\geq 0.1$  second

**Summary of earth fault requirements for unearthed networks (see Table 10-2a)**

Causes	Requirements
Limitation of transient overvoltages	Reinforce the equipment insulation
Selectivity between outgoing feeders	Fit the outgoing feeders with directional earth fault protection devices
Selectivity with downstream protection	If the time delay required is too large, use logic selectivity
Limitation of risk of ferro-resonance	Load the VT secondaries: – in case of resistance on each phase, $R = 68\Omega$ for a secondary voltage equal to $\frac{100}{3} V$ – in case of open delta-connected tertiary, power dissipated in the resistor higher than 50 W
Minimum threshold setting of earth protection. Accuracy of the residual current measurement	Measurement by torroid compulsory  $I_{set} \geq 1 A$ and time delay $\geq 0.1$ second

**Table 10-2a:** earth fault requirements for unearthed networks

**10.1.3. Requirements for phase-to-phase faults****Minimum short-circuit current**

Phase overcurrent protection devices must be activated for the minimum short-circuit current that can flow through them.

At high voltage, it is the phase-to-phase short-circuit current clear of earth at the point furthest away from the zone protected by the protection, with the upstream configuration minimizing the short-circuit current value (see section 4.4.2). (For a network fed by generators disconnected from the utility power supply, refer to section 7.24 to calculate the minimum short-circuit current.)

In order to ensure a safety margin, the condition to be met for the phase overcurrent protection threshold setting is:

$$I_{set} \leq 0.8 I_{sc2,min}$$

For safety reasons, back-up of the downstream protection should also be provided.

#### ***Maximum short-circuit***

- The switching devices must be able to interrupt the maximum short-circuit current (see section 4.1 and 4.2).
- The equipment must withstand the maximum short-circuit current for a maximum time determined by the selectivity system. The maximum time must take into account any eventual failure of the protection located directly upstream (1 safety level).

#### ***Selectivity***

- The maximum time delay at the consumer substation may be stipulated by the manufacturer. In France, EDF (the French electricity authority), stipulates a time delay less than or equal to 0.2 seconds, which means that time-graded selectivity via a circuit-breaker located downstream cannot be used. Logic or differential selectivity must be used when the network is made up of several stages.
- The equipment thermal withstand to the short-circuit current (see section 5.1) defined by the manufacturers is generally 1 second.
- The protection devices must not be activated by normal overloads caused by motor starting or transformer inrush currents.

#### **10.1.4. Network with one incoming feeder**

We shall first of all determine the protection system for phase-to-phase faults and then the system for earth faults.

10.1.4.1. Protection against phase-to-phase faults (see Figure 10-4a)

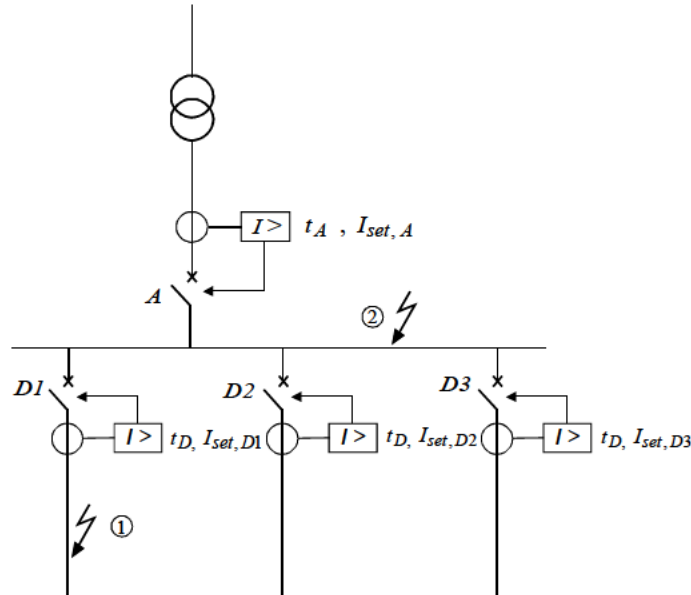


Figure 10-4a: protection against phase-to-phase faults

The incoming feeder at *A* and the outgoing feeders at *D1*, *D2* and *D3* are fitted with phase overcurrent protection (see section 7.1).

The selectivity between the incoming feeder at *A* and the outgoing feeders at *Di* is of the time graded type such that  $t_A \geq t_D + \Delta t$ .

The protection at *D1* detects the fault at ① on the outgoing feeder and causes the circuit-breaker CB1 to be tripped with a time delay  $t_D$ .

The protection at *A* detects the fault at ② on the busbar and causes the circuit-breaker at *A* to be tripped with a time delay  $t_A$ . It also acts as back-up in case the protection of an outgoing feeder or an associated circuit-breaker fails.

**Setting indications**

See requirements in section 10.1.3.

Current thresholds:

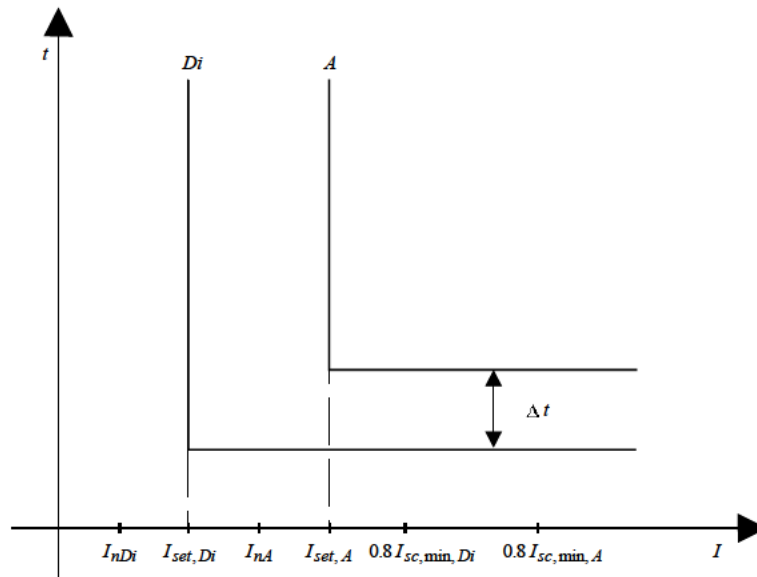
$$I_{set,A} \leq 0.8 I_{sc2,min,A}$$

$$I_{set,Di} \leq 0.8 I_{sc2,min,Di}$$

$$I_{set,A} \geq 1.25 I_{set,Di}$$

Time delays:

$$t_A \geq t_D + \Delta t$$



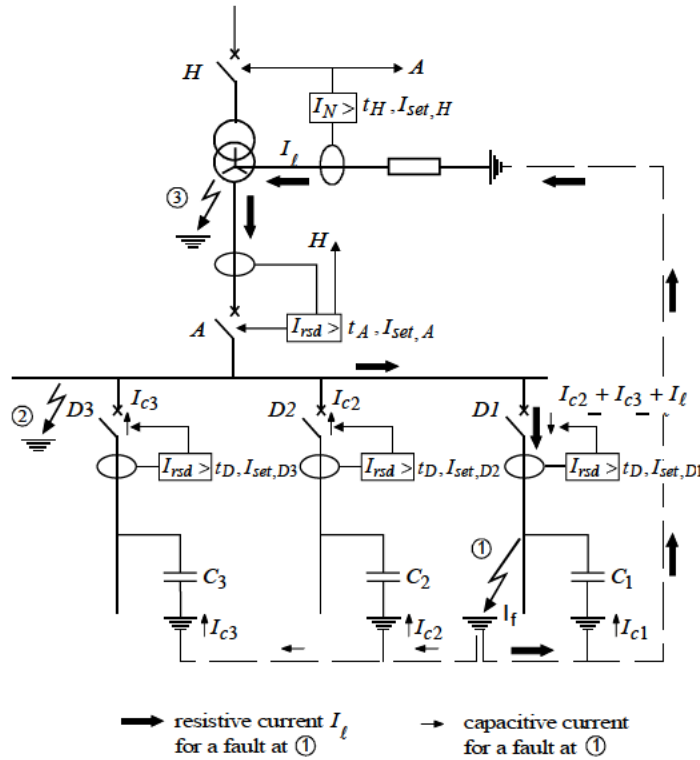
$I_{nA}$ ,  $I_{nDi}$  : nominal current at  $A$  and  $Di$

**Figure 10-4b:** selectivity curve

The protection at  $D$  must be selective with respect to the downstream protection devices. If the time delay required at  $A$  is too large, logic selectivity must be used (see Figure 10-4b and section 9.3).

10.1.4.2. Protection against earth faults

Neutral earthing via resistance on the transformer (see Figure 10-5a)



fault current  $I_f = I_{c1} + I_{c2} + I_{c3} + I_\ell$

Figure 10-5a: neutral earthing via resistance on the transformer

The outgoing feeders, the incoming feeder and the neutral earthing connection are fitted with earth fault protection: see section 7.2.

Selectivity between the protection devices at  $H$ ,  $A$  and  $D_i$  is of the time-graded type.

The protection at  $D1$  detects the fault at ① on the outgoing feeder and causes the circuit-breaker at  $D1$  to be tripped with a time delay  $t_D$ .



The protection at  $A$  detects the fault at ② on the busbar and causes circuit-breakers  $A$  and  $H$  to be tripped with a time delay  $t_A$ .

The protection located on the earthing connection detects the fault at ③ on the transformer and causes circuit-breakers  $H$  and  $A$  to be tripped with a time delay  $t_H$ .

The protection located on the earthing connection acts as back-up in the event of the failure of the protection at  $A$  or the associated circuit-breaker.

The protection at  $A$  acts as back-up in case of failure of the protection of an outgoing feeder or the associated circuit-breaker.

When the condition  $1.3I_{Ci} \leq I_{set,Di}$  cannot be met on an outgoing feeder, directional earth fault protection should be used on this feeder so that a fault current can be distinguished from a capacitive current (see sections 7.4.2 and 10.1.1).

### **Setting indications**

See requirements in section 10.1.1.

Current thresholds:

$$I_{set,H} \geq 1.25I_{set,A}$$

$$I_{set,A} \geq 1.25I_{set,Di}$$

$$I_{set,Di} \geq 1.3I_{Ci}$$

Time delays:

$$t_H \geq t_A + \Delta t$$

$$t_A \geq t_D + \Delta t$$

The protection at  $D$  must be selective with downstream protection devices. If the time delay required at  $H$  is too large, logic selectivity must be used (see Figure 10-5b and section 9.3).

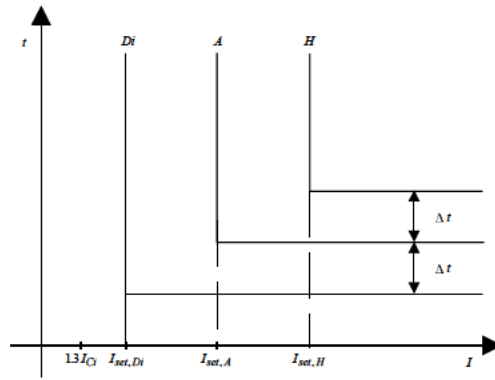


Figure 10-5b: selectivity curves

Neutral earthing via resistor on the busbar (see Figure 10-6)

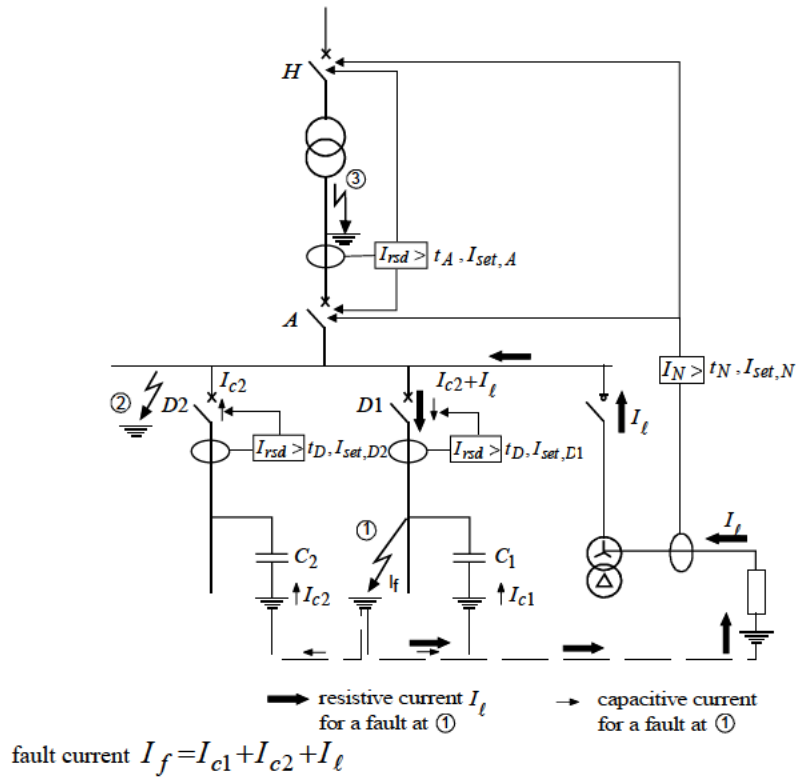


Figure 10-6: neutral earthing via resistor on the busbar

Resistance earthing is established by creating an artificial neutral (see section 2.3.1).

The outgoing feeders, the incoming feeder and the artificial neutral are fitted with earth fault protection (see section 7.2).

Selectivity between the protection devices of the outgoing feeders, the incoming feeder and the artificial neutral is of the time-graded type.

The protection at  $D1$  detects the fault at ① on the outgoing feeder and causes the circuit-breaker  $D1$  to be tripped with a time delay  $t_D$ .

The protection located on the artificial neutral detects the fault at ② on the busbar and causes circuit-breakers  $A$  and  $H$  to be tripped with a time delay  $t_N$ .

The protection located at  $A$  detects the fault at ③ on the transformer and causes circuit-breakers  $H$  and  $A$  to be tripped with a time delay  $t_A$ .

The protection located on the artificial neutral acts as back-up in case of failure of the protection of an outgoing feeder or the incoming feeder  $A$ .

When the condition  $1.3I_{Ci} \leq I_{set,Di}$  cannot be met on an outgoing feeder, directional earth fault protection is used on this outgoing feeder so that a fault current can be distinguished from a capacitive current: see sections 7.4.2 and 10.1.1.

### **Setting indications**

See requirements in section 10.1.1.

Current thresholds:

$$I_{set,N} \geq 1.25 I_{set,Di}$$

$$I_{set,N} \geq 1.25 I_{set,A}$$

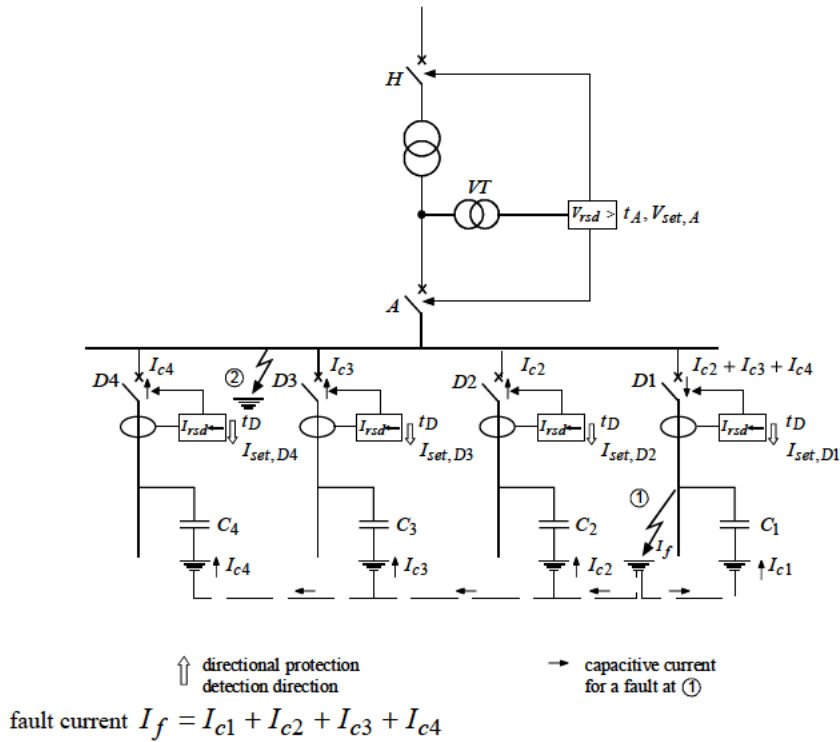
$$I_{set,Di} \geq 1.3 I_{Ci}$$

Time delays:

$$t_N \geq t_A + \Delta t$$

$$t_N \geq t_D + \Delta t$$

**Unearthed neutral (see Figure 10-7)**



**Figure 10-7: unearthed neutral**

*Selective detection of the faulty outgoing feeder*

The fault current at ① recloses through the capacitances of the healthy outgoing feeders and the faulty feeder: see section 4.3.1 and section 4.3.5.

The protection at *D1* detects a current equal to the capacitive current of the healthy feeders, i.e.:

$$I_{D1} = I_{C2} + I_{C3} + I_{C4} = 3j(C_2 + C_3 + C_4) \omega V_n$$

The protection devices at *D2*, *D3* and *D4* detect a current equal to the capacitive current of their own outgoing feeder, i.e.:

$$I_{C2} = 3j C_2 \omega V_n$$

$$I_{C3} = 3 j C_3 \omega V_n$$

$$I_{C4} = 3 j C_4 \omega V_n.$$

For a fault on an outgoing feeder other than  $D1$ , the protection at  $D1$  detects a current equal to the capacitive current of the outgoing feeder, i.e.:

$$I_{C1} = 3 j C_1 \omega V_n.$$

In order to obtain selectivity with the other outgoing feeders at  $D1$ , the protection threshold at  $D1$  must be set such that:

$$1.3 I_{C1} < I_{set,D1} < 0.3 (I_{C2} + I_{C3} + I_{C4})$$

Using the coefficient 0.3 overcomes problems relating to variations in network configuration.

If we apply the same reasoning to protection devices  $D2$ ,  $D3$  and  $D4$  we can see that, in order to obtain selectivity between all the outgoing feeders, the capacitance of an outgoing feeder must be lower than  $\frac{0.3}{1.3}=0.23$  times the sum of the capacitances of the other feeders.

It is difficult to meet this condition, which is why directional earth fault protection devices are used (see section 7.4.3 and 10.1.2), allowing the capacitive current of a healthy feeder to be distinguished from the capacitive current of a faulty feeder.

It is thus possible to set the directional earth fault protection to the minimum measurement accuracy (see section 10.1.2).

In order to detect a fault at ② on the busbar or transformer, residual overvoltage protection is used (see section 7.16).

#### *Operation for first fault tripping with directional protection on the outgoing feeders*

The selectivity between the protection of the busbar and outgoing feeders  $D_i$  is of the time-graded type.

The protection at  $D1$  detects the fault at ① on the outgoing feeder and causes the circuit-breaker  $D1$  to be tripped with a time delay  $t_D$ .

The residual overvoltage protection located at  $A$  detects the fault at ② and causes circuit-breakers  $H$  and  $A$  to be tripped with a time delay  $t_A$ .

The residual overvoltage protection acts as back-up in case of failure of the protection of an outgoing feeder or the associated circuit-breaker.

***Setting indications (See requirements in section 10.1.2)***

Current threshold:

$$I_{set,Di}=1A$$

Residual voltage threshold:

$$V_{set,A}=0.3V_n$$

Time delays:

$$t_D \geq 0.1s$$

$$t_A \geq t_D + \Delta t$$

Note: the residual overvoltage protection can be replaced by a permanent insulation monitor (see section 2.5.1).

**10.1.5. Network with two parallel incoming feeders**

We shall first of all determine the protection system against phase-to-phase faults and then against earth faults.

**10.1.5.1. Protection against phase-to-phase faults (see Figure 10-8)**

Outgoing feeders  $D1$  and  $D2$  are fitted with phase overcurrent protection devices: see section 7.1.

Incoming feeders  $A1$  and  $A2$  are fitted with directional overcurrent protection devices (see section 7.3) and phase overcurrent protection.

The HV incoming feeders  $H1$  and  $H2$  are fitted with phase overcurrent protection devices.

Selectivity between the protection devices of the incoming feeders ( $A1$  and  $A2$ ) and outgoing feeders  $Di$  is of the time-graded type such that  $t_A \geq t_D + \Delta t$ .

Selectivity between the HV incoming feeders ( $H1$  and  $H2$ ) and the incoming feeders ( $A1$  and  $A2$ ) is of the amperometric type.

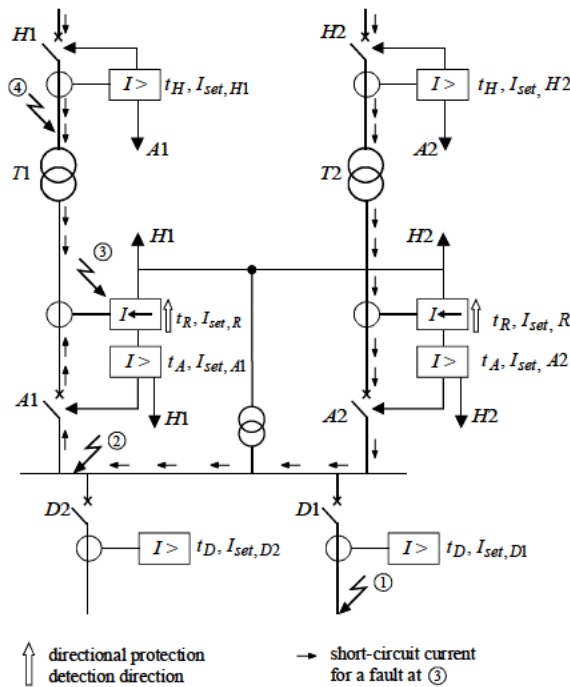


Figure 10-8: protection against phase-to-phase faults

The protection at  $D1$  detects the fault at ① on the outgoing feeder and causes the circuit-breaker  $D1$  to be tripped with a time delay  $t_D$ .

The phase overcurrent protection devices at  $A1$  and  $A2$  detect the fault at ② on the busbar and cause circuit-breakers  $A1$ ,  $H1$ ,  $A2$  and  $H2$  to be tripped with a time delay  $t_A$ .

The directional overcurrent protection at  $A1$  detects the fault at ③ and causes circuit-breakers  $A1$  and  $H1$  to be tripped with a time delay  $t_R$ . The fault at ③ is also detected by the phase overcurrent protection at  $A2$ . Non-tripping is ensured by time-graded selectivity where the time delays are set such that  $t_A \geq t_R + \Delta t$ .

The protection at  $H1$  detects the fault at ④ and causes circuit-breakers  $A1$  and  $H1$  to be tripped with a time delay  $t_H$ . It also acts as back-up of the protection located at  $A1$  (see section 10.3.4.5, transformer protection).

### **Setting indications**

See requirements in section 10.1.3.

Current thresholds:

$$I_{set,H1} \leq 0.8 I_{sc2, \min, H1}$$

$$I_{set,H2} \leq 0.8 I_{sc2, \min, H2}$$

$$I_{set,A1} \leq 0.8 I_{sc2, \min, A1}$$

$$I_{set,A2} \leq 0.8 I_{sc2, \min, A2}$$

$$I_{set,Di} \leq 0.8 I_{sc2, \min, Di}$$

$$I_{set,A1} \geq 1.25 I_{set,Di}$$

$$I_{set,A2} \geq 1.25 I_{set,Di}$$

$$I_{set,R} = 0.5 \text{ to } 1 I_{nA} \quad (I_{nA} = \text{nominal current at } A)$$

For co-ordination between  $I_{set,H}$  and  $I_{set,A}$ , see section 10.3.4.5 concerning transformer protection using double threshold independent time protection.

Time delays:

$$t_A \geq t_D + \Delta t$$

$$t_A \geq t_R + \Delta t$$

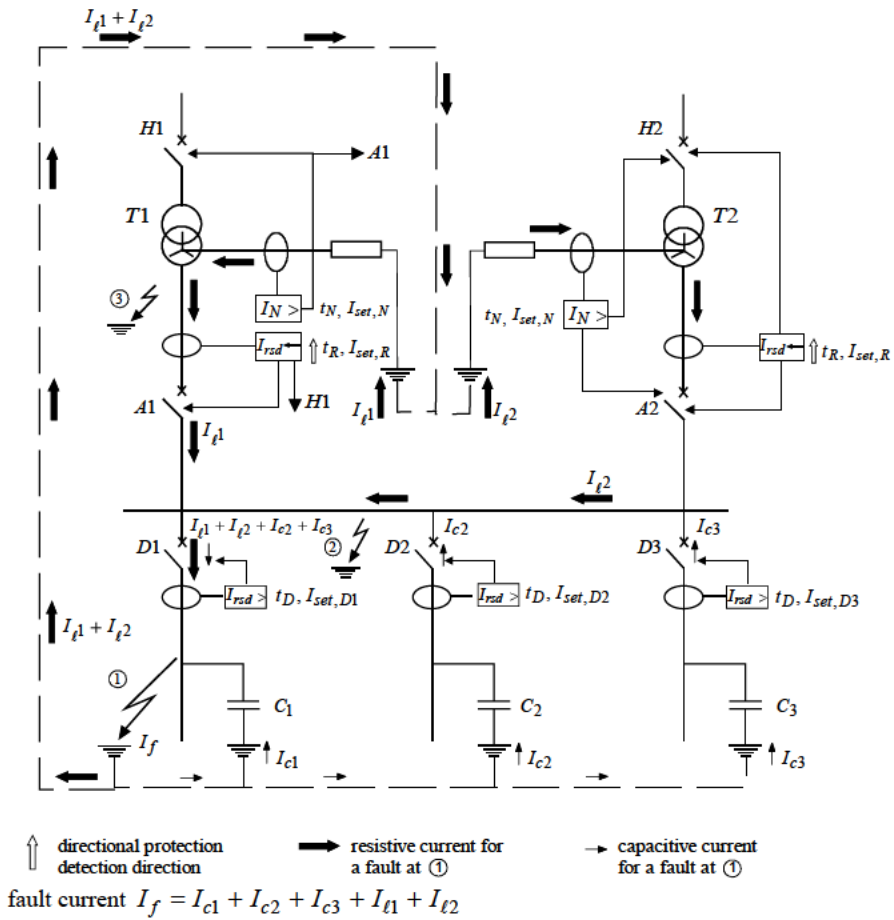
For co-ordination between  $t_H$  and  $t_A$ , see section 10.3.4 concerning transformer protection using double threshold independent time protection.



Note: the directional overcurrent protection located at *A* may be replaced by transformer differential protection (see section 7.6.3).

10.1.5.2. Protection against earth faults

**Neutral earthing via resistance on transformers (see Figure 10-9)**



**Figure 10-9: neutral earthing via resistance on transformers**

The outgoing feeders and earthing connections are fitted with earth fault protection: see section 7.2.

The incoming feeders A1 and A2 are fitted with directional earth fault protection: see section 7.4.2.

The protection at  $D1$  detects the fault at ① on the outgoing feeder and causes the circuit-breaker  $D1$  to be tripped with a time delay  $t_D$ .

The fault at ② is not detected by the directional earth fault protection devices at  $A1$  and  $A2$ , although it is detected by the protection devices located on the earthing connections. These cause circuit-breakers  $A1$ ,  $H1$ ,  $A2$  and  $H2$  to be tripped with a time delay  $t_N$ .

The directional earth fault protection at  $A1$  detects the fault at ③ and causes circuit-breakers  $A1$  and  $H1$  to be tripped with a time delay  $t_R$ .

The protection located on the transformer earthing connection  $T2$  detects the fault at ③ and non-tripping is ensured by time-graded selectivity where the time delays are set such that  $t_N \geq t_R + \Delta t$ .

Selectivity between the earthing connections and outgoing feeders  $Di$  is time-graded such that  $t_N \geq t_D + \Delta t$ .

The protection located on the transformer earthing connection acts as back-up in case the protection located at  $A$  or the protection of an outgoing feeder fails.

### **Setting indications**

See requirements in section 10.1.1.

Current thresholds:

$$I_{set,N} \geq 1.25 I_{set,Di}$$

$$I_{set,Di} \geq 1.3 I_{Ci}$$

$$I_{set,N} \geq 1.25 I_{set,R}$$

$I_{set,R}$  is set as low as possible, i.e. in accordance with the accuracy of the residual current measurement (see section 10.1.1).

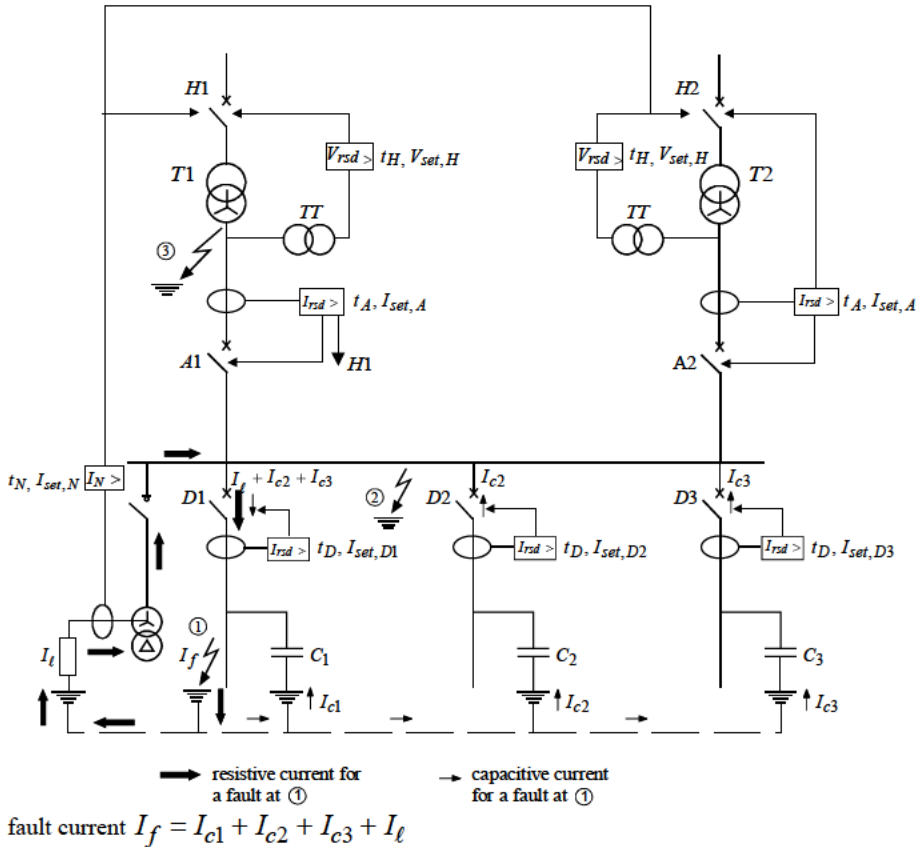
Time delays:

$$t_N \geq t_D + \Delta t$$

$$t_N \geq t_R + \Delta t$$

Note: the directional earth fault protection located at  $A$  may be replaced by restricted earth fault differential protection (see section 7.6.1.2.4).

**Neutral earthing via resistance on the busbar (see Figure 10-10)**



**Figure 10-10: neutral earthing via resistance on the busbar**

Resistance earthing is established by creating an artificial neutral (see section 2.3.1).

The outgoing feeders, the artificial neutral and the incoming feeders A1 and A2 are fitted with earth fault protection: see section 7.2.

The protection at D1 detects the fault at ① on the outgoing feeder and causes the circuit-breaker D1 to be tripped with a time delay  $t_D$ .

The fault at ② is not detected by the earth fault protection located at A1 and A2 because, with the artificial neutral being located on the busbar, the fault current does not flow through the protection devices at A1 and A2. The capacitive current due to

the cables between the transformer and the busbar is neglected, i.e. it is lower than the threshold of the protection located at A.

The protection located on the artificial neutral detects the fault at ② on the busbar and causes circuit-breakers A1, H1, A2 and H2 to be tripped with a time delay  $t_N$ .

The residual overvoltage protection located at T2 detects the fault at ②. Non-tripping is ensured by time-graded selectivity where the time delays are set such that  $t_H \geq t_N + \Delta t$ .

The earth fault protection at A1 detects the fault at ③ and causes circuit-breakers A1 and H1 to be tripped with a time delay  $t_A$ .

The residual overvoltage protection located at T2 detects the fault at ③. Non-tripping is ensured by time-graded selectivity where the time delays are set such that  $t_H \geq t_A + \Delta t$ .

The residual overvoltage protection provides transformer protection (the fault at ③) when the circuit-breaker at A is open. Furthermore, it acts as back-up in case the protection of an incoming feeder or an outgoing feeder fails.

### **Setting indications**

See requirements in section 10.1.1.

Current thresholds:

$$I_{set,N} \geq 1.25 I_{set,Di}$$

$$I_{set,Di} \geq 1.3 I_{Ci}$$

$$I_{set,N} \geq 1.25 I_{set,A}$$

Residual voltage threshold:

$$V_{set,H} = 0.3 V_n$$

Time delays:

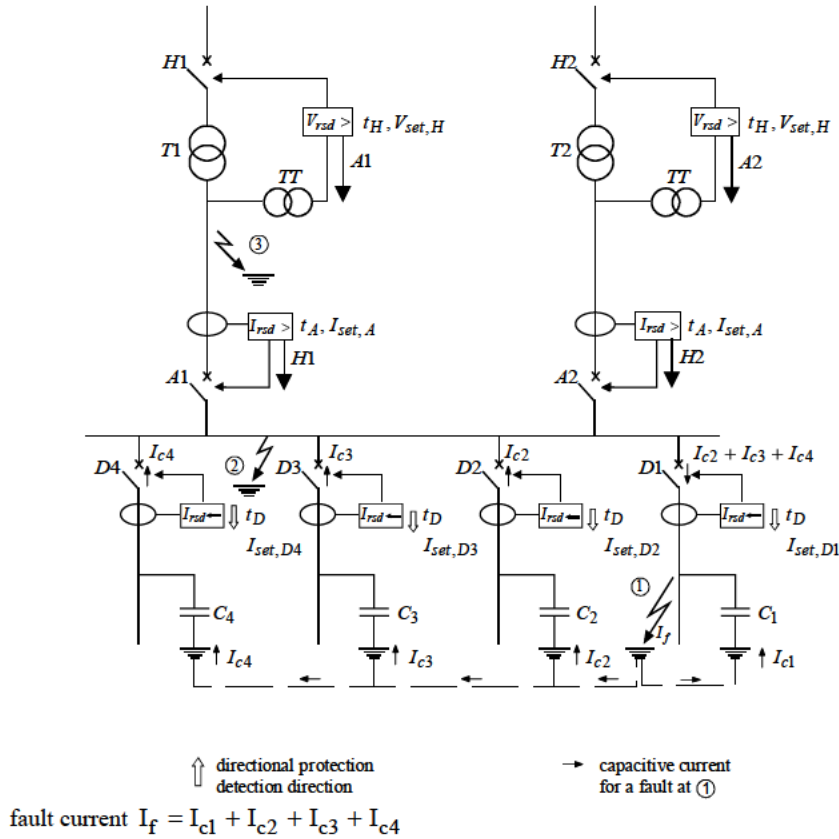
$$t_N \geq t_D + \Delta t$$

$$t_N \geq t_A + \Delta t$$

$$t_H \geq t_A + \Delta t$$

$$t_H \geq t_N + \Delta t$$

**Unearthed neutral (see Figure 10-11)**



**Figure 10-11: unearthed neutral**

Selective detection of the faulty outgoing feeder is identical to the case of the unearthed neutral of a network with one incoming feeder: see section 10.1.4.2. Directional earth fault protection devices are used on the outgoing feeders (see sections 7.4.3 and 10.1.2).

The fault at ② is not detected by the earth fault protection devices located at A1 and A2 because the capacitance of the link connecting the busbar to the transformer is generally negligible.

The residual overvoltage protection devices (see section 7.16) detect the fault at ② on the busbar and cause circuit-breakers A1, H1, A2 and H2 to be tripped with a time delay  $t_H$ .

The earth fault protection at A1 detects the fault at ③ and causes circuit-breakers A1 and H1 to be tripped with a time delay  $t_A$ .

The residual overvoltage protection on T2 detects the fault at ③ and non-tripping is ensured by time-graded selectivity where the time delays are set such that  $t_H \geq t_A + \Delta t$ .

The residual overvoltage protection protects the transformer (fault at ③) when the circuit-breaker A is open. Furthermore, it acts as back-up in case the protection of an incoming or an outgoing feeder fails.

Especially when no outgoing feeder is in service, a fault at ③ causes a very low capacitive current, which is unlikely to be detected by the protection at A; the residual overvoltage protection acts as back-up.

### ***Setting indications***

See section 10.1.2.

Current thresholds:

$$I_{\text{set},D_i} = 1 \text{ A}$$

$$I_{\text{set},A} \geq 1.3 I_{CA}$$

$C_A$ : capacitance between the circuit-breaker  $A_1$  (or  $A_2$ ) and the transformer  $T_1$  (or  $T_2$ )

Residual voltage threshold:

$$V_{\text{set},H} = 0.3 V_n$$

Time delays:

$$t_H \geq t_D + \Delta t$$

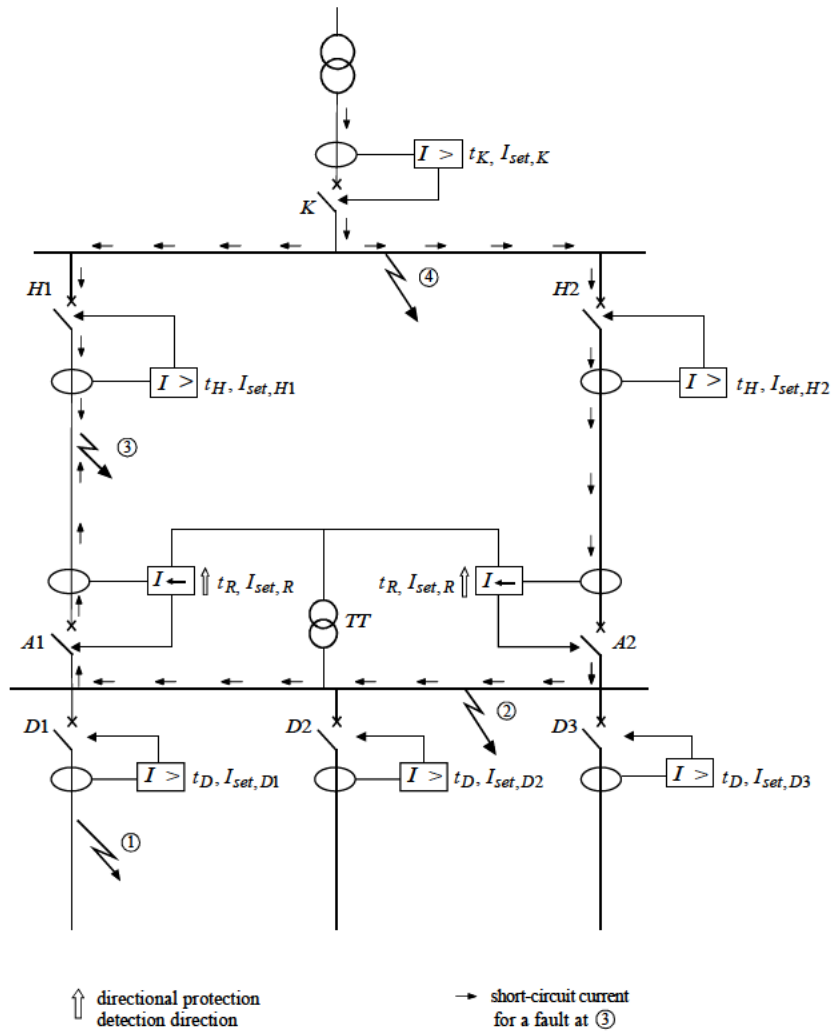
$$t_H \geq t_A + \Delta t$$

Note: the residual overvoltage protection devices may be replaced by a permanent insulation monitor (see section 2.5.1). In this case, logic selectivity must be used so that the two PIMs are not able to operate in parallel because, if they do, they flow into one another and permanently detect a fault. The neutral of the voltage transformers must therefore be earthed through a capacitor and an overvoltage limiter in parallel.

**10.1.6. Network with two looped incoming feeders**

We shall first of all determine the system of protection against phase-to-phase faults and then against earth faults.

10.1.6.1. Protection against phase-to-phase faults (see Figure 10-12)



**Figure 10-12: protection against phase-to-phase faults**

The outgoing feeders  $D1, D2$  and  $D3$  are fitted with phase overcurrent protection devices (see section 7.1).

The incoming feeders  $A1$  and  $A2$  are fitted with directional overcurrent protection devices (see section 7.3).

$H1$  and  $H2$  are fitted with phase overcurrent protection devices.

The protection at  $D1$  detects the fault at ① on the outgoing feeder and causes the circuit-breaker  $D1$  to be tripped with a time delay  $t_D$ .

The fault current at ② is not detected by the directional overcurrent protection devices  $A1$  and  $A2$ .

The protection devices at  $H1$  and  $H2$  detect the fault at ② on the busbar and cause circuit-breakers  $H1$  and  $H2$  to be tripped with a time delay  $t_H$ .

Selectivity between the protection devices at  $H1$  and  $H2$  and the protection devices of the outgoing feeders  $D_i$  is time-graded such that  $t_H \geq t_D + \Delta t$ .

The directional overcurrent protection at  $A1$  detects the fault at ③ and causes the circuit-breaker  $A1$  to be tripped with a time delay  $t_R$ .

The fault at ③ is also detected by the phase overcurrent protection at  $H2$ . Non-tripping is ensured by time-graded selectivity where the time delays are set such that  $t_H \geq t_R + \Delta t$ .

The fault at ③ is also fed at  $H1$  whose protection causes the circuit-breaker  $H1$  to be tripped with a time delay  $t_H$ .

The phase overcurrent protection at  $K$  detects the fault at ④ and causes the circuit-breaker  $K$  to be tripped with a time delay  $t_K$ .

### ***Setting indications***

See requirements in section 10.1.3.



Current thresholds:

$$I_{set,K} \leq 0.8 I_{sc2,min,K}$$

$$I_{set,H1} \leq 0.8 I_{sc2,min,H1}$$

$$I_{set,H2} \leq 0.8 I_{sc2,min,H2}$$

$$I_{set,A1} \leq 0.8 I_{sc2,min,A1}$$

$$I_{set,A2} \leq 0.8 I_{sc2,min,A2}$$

$$I_{set,Di} \leq 0.8 I_{sc2,min,Di}$$

$$I_{set,H} \geq 1.25 I_{set,Di}$$

$$I_{set,H} \geq 1.25 I_{set,R}$$

$$I_{set,R} = 0.5 \text{ to } 1 I_{nA} \quad (I_{nA} = \text{nominal current at } A)$$

Time delays:

$$t_K \geq t_H + t_R + \Delta t$$

$$t_H \geq t_R + \Delta t$$

$$t_H \geq t_D + \Delta t$$

Note: the short-circuit current is split between both branches in relation to the branch impedance and the position of the fault. Thus, for a fault at ③, close to  $H1$ , the short-circuit current is very low at  $A1$ , whereas it is high at  $H1$  (the short-circuit current is split in proportion to the impedances of the two current circulation paths). The short-circuit current at  $A1$  may be lower than the current threshold and the protection is only activated once the circuit-breaker  $H1$  has been tripped (the entire short-circuit current then circulates via  $A1$ ). The fault clearance time is  $t_H + t_R$  and the protection located at  $K$  must be time-delayed as a consequence, i.e.  $t_K \geq t_H + t_R + \Delta t$ .

10.1.6.2. Protection against earth faults

Neutral earthing via resistance on the transformer (see Figure 10-13)

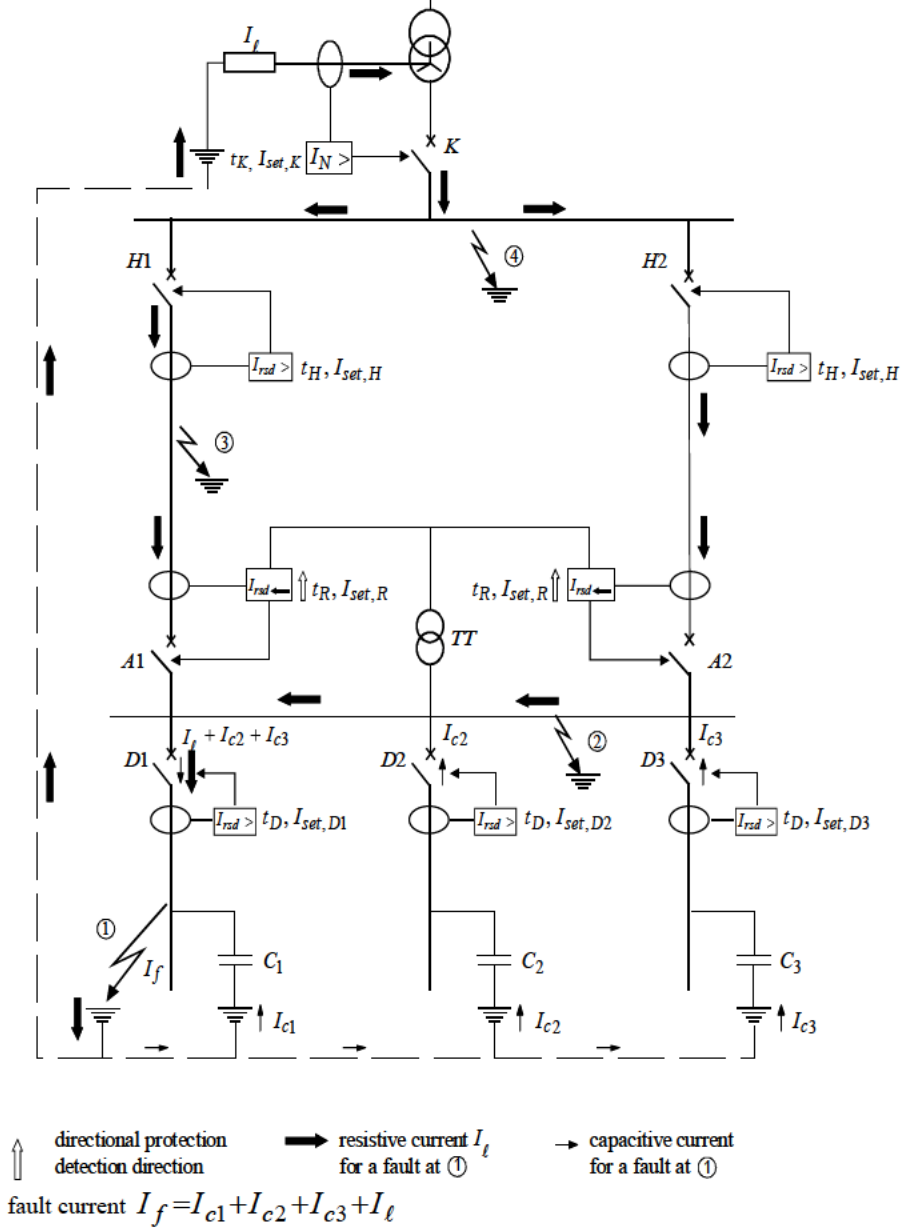


Figure 10-13: neutral earthing via resistance on the transformer

The outgoing feeders and the neutral earthing connection are fitted with earth fault protection (see section 7.2).

$H1$  and  $H2$  are fitted with earth fault protection (see section 7.2).

The incoming feeders  $A1$  and  $A2$  are fitted with directional earth fault protection (see section 7.4.2).

The protection at  $D1$  detects the fault at ① on the outgoing feeder and causes the circuit-breaker  $D1$  to be tripped with a time delay  $t_D$ .

The fault at ② is not detected by the directional earth fault protection devices located at  $A1$  and  $A2$ .

The protection devices at  $H1$  and  $H2$  detect the fault at ② on the busbar and cause circuit-breakers  $H1$  and  $H2$  to be tripped with a time delay  $t_H$ .

The directional earth fault protection at  $A1$  detects the fault at ③ and causes circuit-breaker  $A1$  to be tripped with a time delay  $t_R$ . The fault at ③ is also fed at  $H1$  whose protection causes circuit-breaker  $H1$  to be tripped with a time delay  $t_H$ .

The protection located at  $H2$  detects the fault at ③. Non-tripping is ensured by time-graded selectivity where the time delays are set such that  $t_H \geq t_R + \Delta t$ .

The protection located on the neutral earthing connection detects the fault at ④ and causes the circuit-breaker  $K$  to be tripped with a time delay  $t_K$ .

Selectivity between the protection devices of the outgoing feeders  $Di$ ,  $H1$  and  $H2$  and the neutral earthing connection is time-graded.

### **Setting indications**

See requirements in section 10.1.1.

Current thresholds:

$$I_{set,H} \geq 1.25 I_{set,Di}$$

$$I_{set,K} \geq 1.25 I_{set,H}$$

$$I_{set,H} \geq 1.25 I_{set,R}$$

$$I_{set,Di} \geq 1.3 I_{Ci}$$

$I_{set,R}$  is set as low as possible, i.e. in accordance with the measurement accuracy of the residual current (see section 10.1.1).

Time delays:

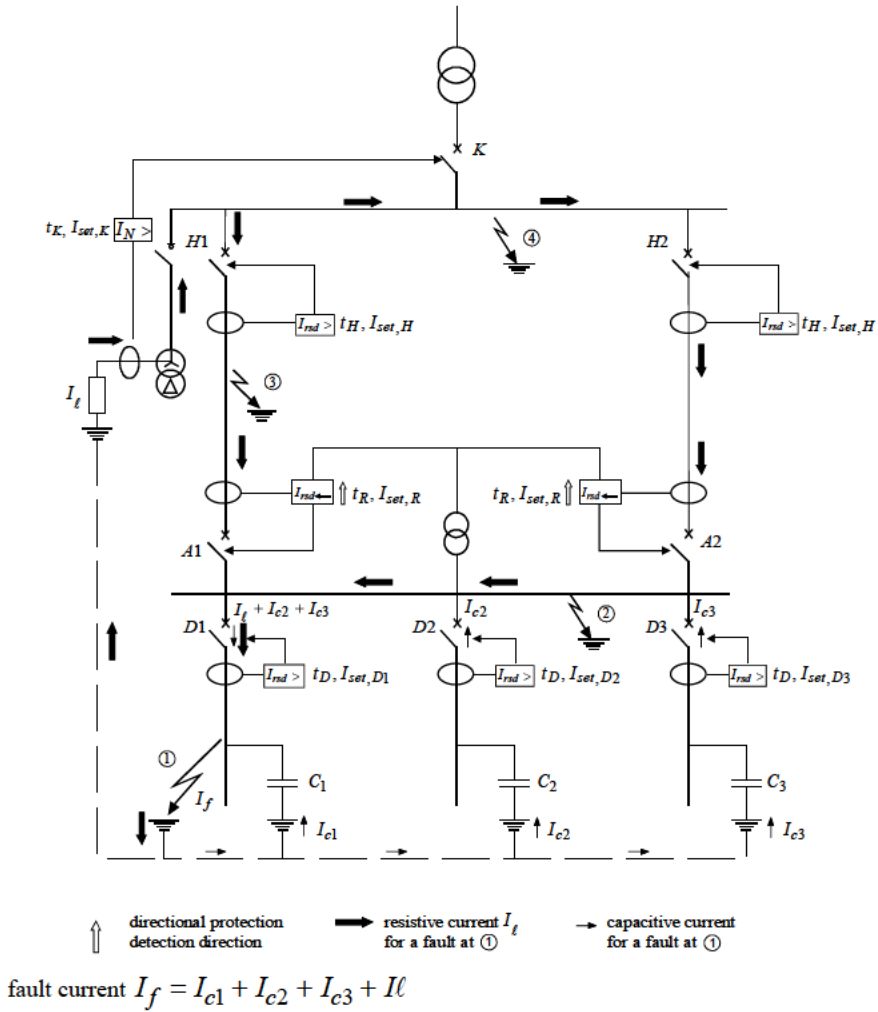
$$t_K \geq t_H + t_R + \Delta t$$

$$t_H \geq t_D + \Delta t$$

$$t_H \geq t_R + \Delta t$$

Note: the short-circuit current is split between the two branches in relation to the branch impedance and the position of the fault. Thus, for a fault at ③, close to  $H1$ , the short-circuit current is very small at  $A1$ , whereas it is large at  $H1$  (the short-circuit current is split in proportion to the impedances of the two current circulation paths). The short-circuit current at  $A1$  may be smaller than the current threshold and protection is only activated once the circuit-breaker  $H1$  has been tripped (the entire short-circuit current then circulates via  $A1$ ). The fault clearance time is  $t_H + t_R$  and the protection located at  $K$  must be time-delayed as a consequence, i.e.  $t_K \geq t_H + t_R + \Delta t$ .

*Neutral earthing via resistance on the busbar (see Figure 10-14)*



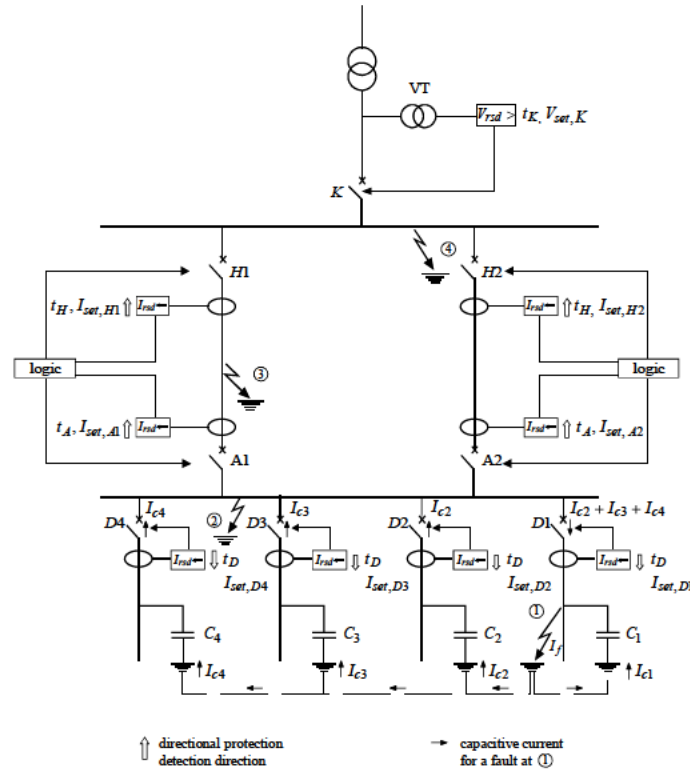
**Figure 10-14:** neutral earthing via resistance on the busbar

Resistance earthing is established by creating an artificial neutral (see section 2.3.1).

The protection system is identical to the case of earthing on the transformer.

The protection located on the artificial neutral fulfills the role of the protection located on the neutral earthing connection.

**Unearthed neutral (see Figure 10-15)**



$$\text{fault current } I_f = I_{c1} + I_{c2} + I_{c3} + I_{c4}$$

**Figure 10-15: ungrounded neutral**

Selective detection of the faulty outgoing feeder is identical to the case of the ungrounded neutral of a network with one incoming feeder (see section 10.1.4.2). Directional earth fault protection devices are used on the outgoing feeders (see sections 7.4.3 and 10.1.2).

The fault at ② is not detected by the directional earth fault protection devices located at A1, A2, D1 ... D4 because the capacitive currents detected by these protection devices are not in the detection direction provided for.

The residual overvoltage protection (see section 7.16) detects the fault at ② on the busbar and causes circuit-breaker  $K$  to be tripped with a time delay  $t_K$ .

For a fault at ③, the capacitive currents from the outgoing feeders are reclosed via the two parallel links, with the current values in each link depending on the position of the fault. These capacitive currents are thus detected by the protection devices located at  $A1$ ,  $A2$ ,  $H1$  and  $H2$ . To obtain selectivity between the two links, directional earth fault protection devices must be installed (see section 7.4.3) with a logic exchange between the two ends of a link. If both protection devices are activated, the currents flow in the same direction and the tripping orders are locked.

For a fault at ③, the protection devices located  $A2$  at and  $H2$  see a current flowing in the same direction and the tripping orders are locked.

The protection devices located at  $A1$  and  $H1$  see a current flowing in the opposite direction and a tripping order is given to circuit-breakers  $A1$  and  $H1$ .

The residual overvoltage protection (see section 7.16) detects the fault at ④ and causes the circuit-breaker  $K$  to be tripped with a time delay  $t_K$ .

Selectivity between the incoming protection  $K$  and the outgoing feeders  $Di$  is of the time-graded type.

### **Setting indications**

See requirements in section 10.1.2.

Current thresholds:

$$I_{set,Di} = 1 A$$

$$1.3 I_{CA1H1} \leq I_{set,H1} = I_{set,A1} \leq 0.2 I_C$$

$$1.3 I_{CA2H2} \leq I_{set,H2} = I_{set,A2} \leq 0.2 I_C$$

$I_{CA1H1}$  : capacitive current of the  $A1 \rightarrow H1$  link

$I_{CA2H2}$  : capacitive current of the  $A2 \rightarrow H2$  link

$I_C$  : total capacitive current of the network

Residual voltage threshold:

$$V_{set,K} = 0.3 V_n$$

Time delays:

$$t_K \geq t_D + \Delta t$$

$$t_A = t_H = 0.1 \text{ to } 0.2 \text{ s}$$

(the time needed for the logic information exchanges must be taken into account).

Note: if the length of links  $A1 \rightarrow H1$  and  $A2 \rightarrow H2$  is short, high impedance differential protection devices may be installed (see section 7.6.1). These can be used to obtain selectivity between the two parallel links. The current threshold must be set above the capacitive current of the protected link.

#### 10.1.7. Loop network

In a distribution network comprising substations fed in a loop arrangement, protection may be provided in the following ways.

##### *At the head of the loop only*

The loop heads are fitted with circuit-breakers. The substations are fitted with switches. The network must be used in an open loop arrangement. Faults cause power cuts.

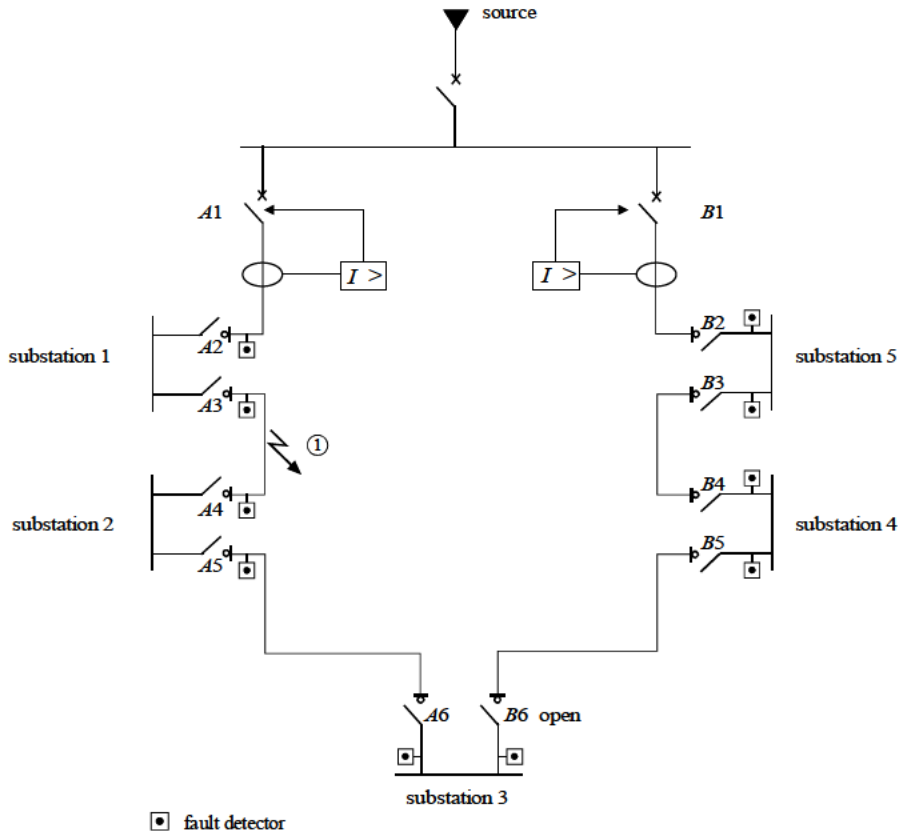
##### *By sections*

Each link end is fitted with a circuit-breaker. During normal operation, the network is used in a closed loop arrangement. Most faults do not cause a power cut.

##### 10.1.7.1. Protection at the head of the loop (see Figure 10-16)

The loop heads at A1 and B1 are fitted with circuit-breakers, and phase and earth fault protection devices. The substations are fitted with switches.





**Figure 10-16:** protection at the head of the loop

Fault detectors are installed on each switch. They indicate the passage of a fault current.

During normal operation, the loop is open. In the figure, it is assumed that it is open at B6.

**Operation in the event of a fault**

- The protection at A1 detects the fault at ①, and causes the circuit-breaker A1 to be tripped.
- The link is de-energized from A1 to B6, and substations 1, 2 and 3 are no longer fed.

- The fault detectors located at A2 and A3 indicate the passage of a fault current. The other detectors do not send a signal. The fault is located. The user opens switches A3 and A4 in order to put the faulty link out of service.
- The closing of the switch B6 enables substations 2 and 3 to be fed again.
- The closing of the circuit-breaker A1 enables substation 1 to be fed again.

After the faulty link has been repaired, switches A3 and A4 are closed and switch B6 is kept open so that the loop can be opened and initial operating conditions restored.

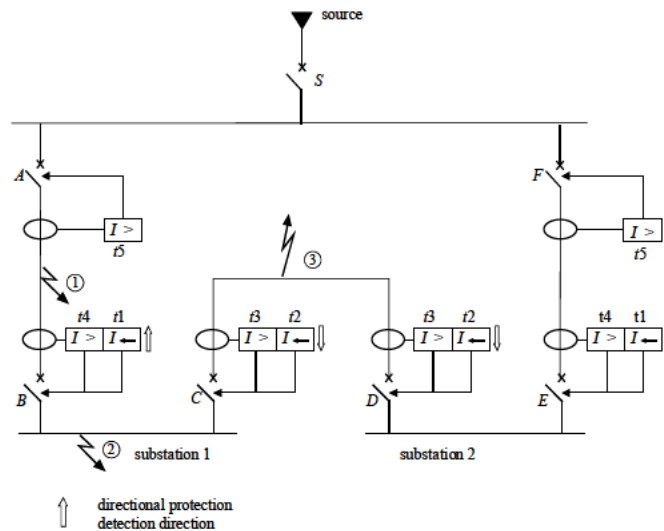
This loop protection system enables a fault to be located but causes power cuts. These cuts last up to several seconds if an automatic loop reconfiguration system is installed. They last for several minutes or tens of minutes if the loop is reconfigured manually by the operating personnel.

This protection system is often used in MV urban networks.

**10.1.8. Protection by section**

Each link end is fitted with a circuit-breaker. During normal operation, the loop is closed. The protection systems will allow power cuts to be avoided when a fault occurs.

*Solution using overcurrent and directional overcurrent protection devices (see Figure 10-17)*



**Figure 10-17:** solution using overcurrent and directional overcurrent protection devices

This solution can only be implemented when a loop is limited to two substations.

Time-graded selectivity leads to time delays that are prohibitive for most substations. If the loop is extended in the future, this will lead to a change in the protection system.

Fault at ①:

- The directional overcurrent protection at B detects the fault and causes the circuit-breaker B to be tripped with a time delay  $t_1$ .
- The overcurrent protection at A detects the fault and causes the circuit-breaker A to be tripped with a time delay  $t_5$ .

Fault at ②:

- The directional overcurrent protection at C detects the fault and causes the circuit-breaker C to be tripped with a time delay  $t_2$ .
- The overcurrent protection at B detects the fault and causes the circuit-breaker B to be tripped with a time delay  $t_4$ .

Fault at ③:

- The overcurrent protection devices C and D detect the fault and cause the circuit-breakers C and D to be tripped with a time delay  $t_3$ .

A fault is detected at each protection stage and the time-graded selectivity therefore requires that:

$$t_5 \geq t_4 + \Delta t$$

$$t_4 \geq t_3 + \Delta t$$

$$t_3 \geq t_2 + \Delta t$$

$$t_2 \geq t_1 + \Delta t$$

This then gives us at best  $t_5 \geq t_1 + 4 \Delta t$ .

By taking  $\Delta t = 0.3 \text{ s}$ , we obtain  $t_5 \geq t_1 + 1.2$ .

*For example:*

$$t_1 = 0.1 \text{ s}$$

$$t_2 = 0.4 \text{ s}$$

$$t_3 = 0.7 \text{ s}$$

$$t_4 = 1 \text{ s}$$

$$t_5 = 1.3 \text{ s}$$

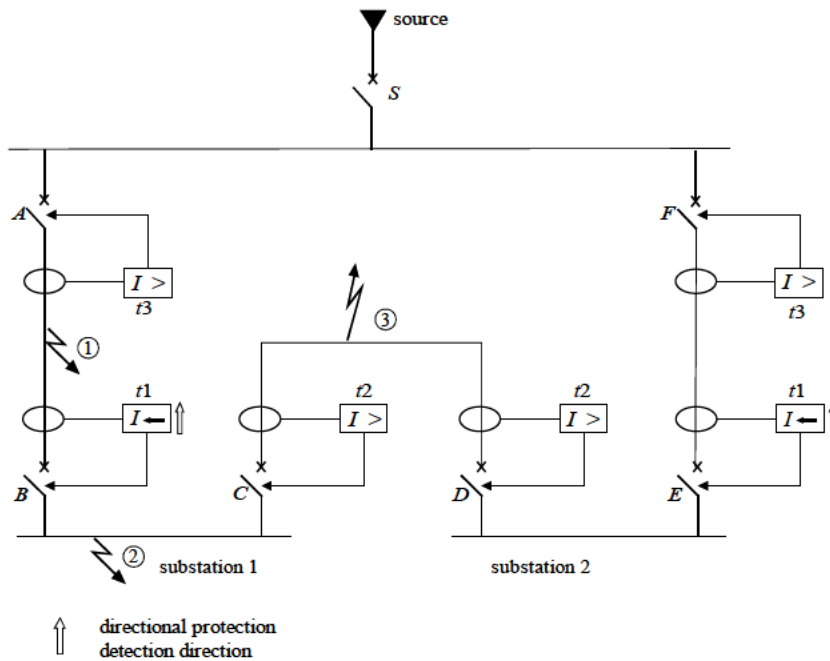
The time delay  $t_5$  of the circuit-breaker A is thus only just acceptable for the thermal withstand of equipment to the short-circuit current.

Note: at each substation, the minimum tripping time  $t_2$  must be selective with the protection devices downstream of the substation.

Selectivity between the protection of the source  $S$  and the protection devices of the loop must be of the logic type (see section 10.2.1), so that the time delay of the protection at  $S$  is not too large. Another solution consists of installing busbar differential protection (see section 10.2.2).

This method does not require a remote link, is simple and is not very costly. It does, however, necessitate long time delays and its application is limited to two substations.

*Solution using overcurrent and directional overcurrent protection devices by saving on one protection out of two (see Figure 10-18)*



**Figure 10-18:** solution using overcurrent and directional overcurrent protection devices by saving on one protection out of two

If we look at the figure, we see that for a fault at ②, selectivity between points A and B is not absolutely essential because there is no consumer on the link between A and B.

Similarly, for a fault at ②, selectivity between points C and D is not absolutely essential.

This situation allows us to split the number of protection functions in two. Furthermore, time-graded selectivity requires shorter time delays.

Fault at ①:

- The directional overcurrent protection at B detects the fault and causes the circuit-breaker B to be tripped with a time delay  $t_1$ .
- The overcurrent protection at A detects the fault and causes the circuit-breaker A to be tripped with a time delay  $t_3$ .

Fault at ②:

- The overcurrent protection devices at C and D detect the fault and cause circuit-breakers C and D to be tripped with a time delay  $t_2$ .
- The overcurrent protection at A detects the fault and causes the circuit-breaker A to be tripped with a time delay  $t_3$ .

Fault at ③:

- The overcurrent protection devices at C and D detect the fault and cause circuit-breakers C and D to be tripped with a time delay  $t_2$ .

A fault is detected at each protection stage and the time-graded selectivity therefore requires that:

$$t_2 \geq t_1 + \Delta t$$

$$t_3 \geq t_2 + \Delta t$$

We thus have at best  $t_3 \geq t_1 + 2 \Delta t$ .

For example:

$$t_1 = 0.1 \text{ s}$$

$$t_2 = 0.4 \text{ s}$$

$$t_3 = 0.7 \text{ s}$$

The time delay  $t_3$  of the circuit-breaker A is thus quite acceptable for the thermal withstand of the equipment in relation to the short-circuit current.

Note: at each substation, the minimum tripping time  $t_2$  must be selective with the downstream protection devices of the substation.

Selectivity between the protection of the source  $S$  and the protection devices of the loop must be of the time-graded type or, preferentially, the logic type (see section 10.2.1), so that the time delay of the protection at  $S$  is not too great. Another solution consists of installing busbar differential protection (see section 10.2.2).

This method does not require a remote link, is simple and is not very costly. The disadvantage is that the time delays are too long when applied to more than two substations. If the loop is extended in the future, this will lead to a change in the protection system.

***Solution using logic selectivity (see Figure 10-19 a)***

For an explanation of logic selectivity, see section 9.3.

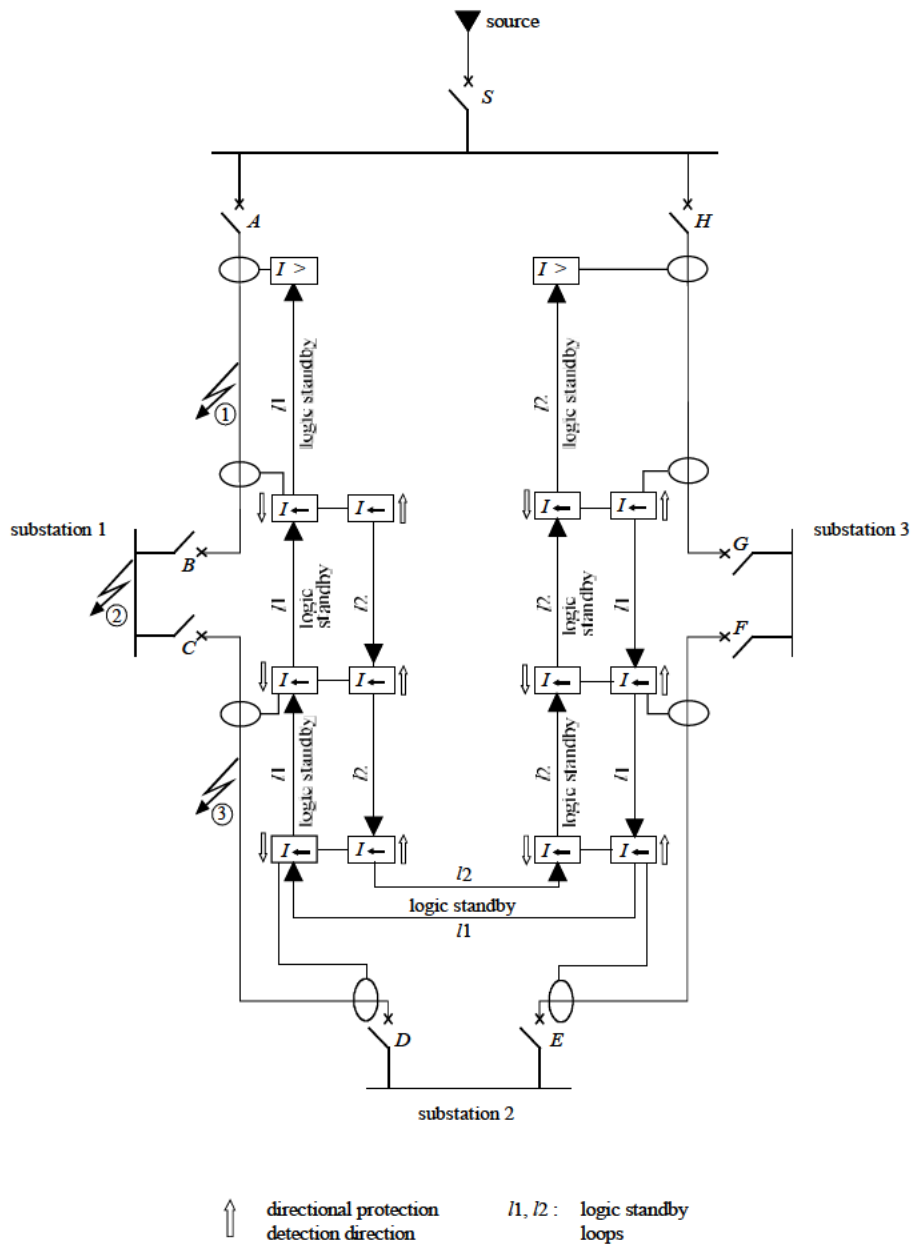


Figure 10-19a: solution using logic selectivity

Logic selectivity allows this solution to be implemented with a large number of substations, and avoiding prohibitive time delays.

Each circuit-breaker in the loop (except A and H) is fitted with two directional overcurrent protection devices, which detect currents flowing in opposite directions.

Two opposite direction logic standby loops  $I1$  and  $I2$  are installed:

Fault at ①:

- The overcurrent protection at A detects the fault and causes the circuit-breaker A to be tripped.

- The directional overcurrent protection at B, which is directed towards the fault, is activated, a logic standby order is given to the protection devices at C, D, E, F, G and H (loop  $I2$ ), and the circuit-breaker B is tripped.

Fault at ②:

- The directional overcurrent protection at B, which is directed towards the fault, is activated, a logic standby order is given to the protection at A (loop  $I1$ ), and the circuit-breaker B is tripped.

- The directional overcurrent protection at C, which is directed towards the fault, is activated, a logic standby order is given to the protection devices at D, E, F, G and H (loop  $I2$ ), and the circuit-breaker C is tripped.

Fault at ③:

- The directional overcurrent protection at C, which is directed towards the fault, is activated, a logic standby order is given to the protection at B and A (loop  $I1$ ), and the circuit-breaker C is tripped.

- The directional overcurrent protection at D, which is directed towards the fault, is activated, a logic standby order is given to the protection devices E, F, G and H (loop  $I2$ ), and the circuit-breaker D is tripped.

The directional protection devices directed towards the substations protect the busbars and must be selective with the downstream protection devices.

The directional protection devices directed towards the cables may have identical time delays.

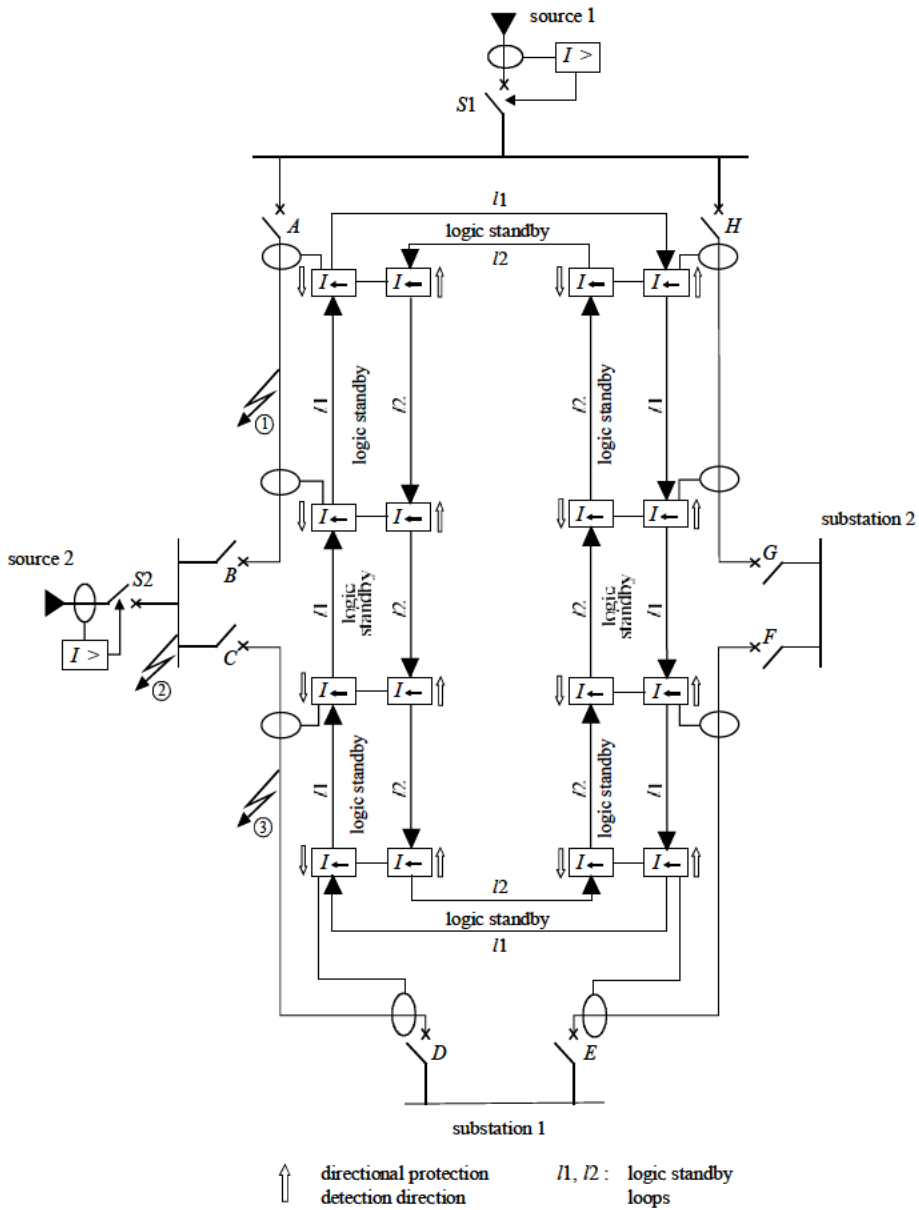
The protection time delays must be longer than the logic standby order transmission and reception times, i.e. 0.1 to 0.2 seconds, depending on the equipment.

Selectivity between the protection of the source  $S$  and the loop protection devices may be of the time-graded or logic type (see section 10.2.1). Another solution consists of installing busbar differential protection (see section 10.2.2).



*Several power sources located at different points (see Figure 10-19b)*

For the explanation of the logic selectivity principle, see section 9.3.



**Figure 10-19b:** *several power sources located at different points*

Two power sources are shown in Figure 10-19b. The protection system is nevertheless the same for a greater number of sources.

Each circuit-breaker in the loop is fitted with directional overcurrent protection devices which detect currents flowing in opposite directions.

Two opposite direction logic standby loops are installed.

Fault at ①:

- The protection devices at A and B, which are directed towards the fault, are activated, a logic standby order is given to all the other protection devices (loops *I1* and *I2*), and circuit-breakers A and B are tripped.

Fault at ②:

- The protection devices at B and C, which are directed towards the fault, are activated, a logic standby order is given to all the other protection devices (loops *I1* and *I2*), and circuit-breakers B and C are tripped.

- The protection at S2 detects the fault and causes circuit-breaker S2 to be tripped.

Fault at ③:

- The protection devices at C and D, which are directed towards the fault, are activated, a logic standby order is given to all the other protection devices (loops *I1* and *I2*), and circuit-breakers C and D are tripped.

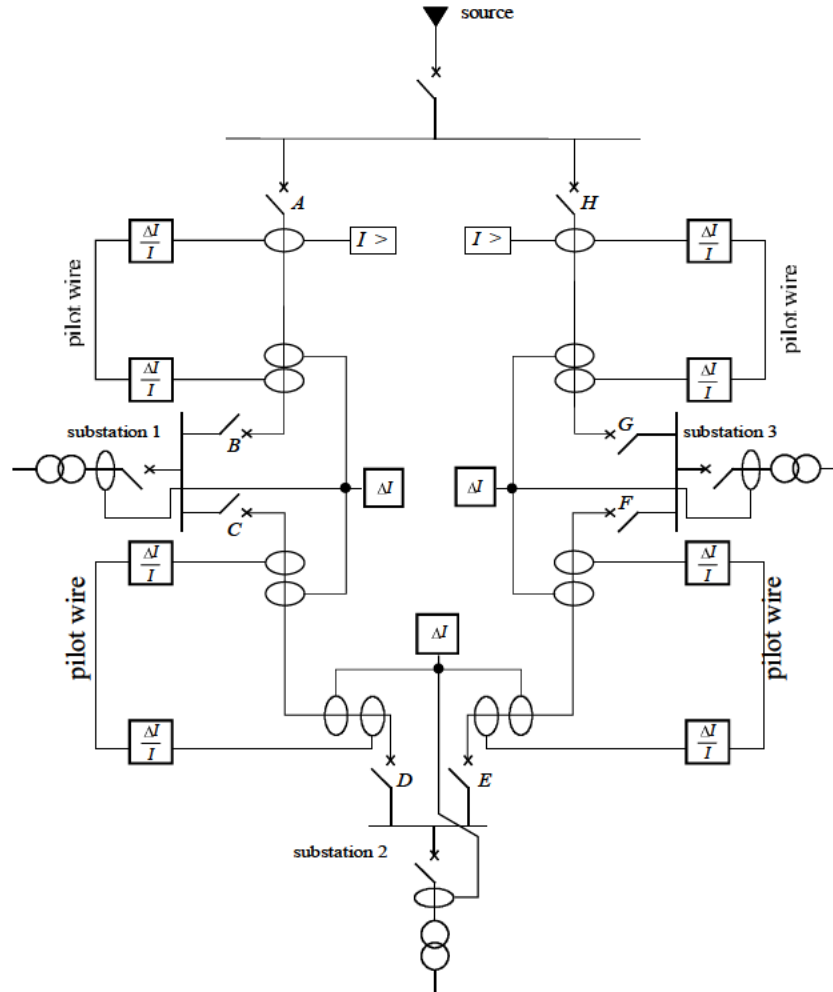
The directional protection devices directed towards the substations protect the busbars and must be selective with the downstream protection devices.

The directional protection devices directed towards the cables may have identical time delays.

The protection time delays must be longer than the logic standby order transmission and reception time, i.e. 0.1 to 0.2 seconds, depending on the equipment.

Selectivity between the protection devices of the sources (S1 and S2) and the loop protection devices may be of the time-graded or logic type (see section 10.2.1). Another solution consists of installing busbar differential protection (see section 10.2.2).

*Solution using differential protection devices (see Figure 10-20a)*



$\Delta I$  : high impedance differential protection for busbar

$\frac{\Delta I}{I}$  : pilot wire differential protection

**Figure 10-20a:** solution using differential protection devices

Each link is fitted with pilot wire differential protection (see section 7.6.2).

Each substation busbar is fitted with high impedance differential protection (see section 10.2.2).

The loop head circuit-breakers are fitted with overcurrent protection devices. They are activated in the event that a differential protection or circuit-breaker fails.

***Comparison between the differential protection solution and logic selectivity solution (see Table 10-2b)***

<b>Element of comparison</b>	<b>Differential protection solution</b>	<b>Logic selectivity solution</b>
<b>Detection of low fault currents</b>	Yes Setting lower than nominal current	No Setting higher than nominal current
<b>Time delay settings</b>	Instantaneous	0.1 to 0.2 seconds depending on the equipment
<b>Back-up protection</b>	Overcurrent protection at loop head	Time-graded selectivity (this is included in the Sepam logic system of Schneider)
<b>If a protection or circuit-breaker fails</b>	Total loss of the loop due to loop head being tripped	Loss of an extra section only due to tripping of the adjacent circuit-breaker
<b>Cost</b>	<ul style="list-style-type: none"> <li>– Costly protection devices</li> <li>– Necessity to use highly efficient current transformers (high knee-point voltage; see section 6.1.3.6)</li> </ul>	<ul style="list-style-type: none"> <li>– More economical protection devices</li> <li>– Average performance current transformers</li> </ul>

**Table 10-2b:** *comparison between differential protection and logic selectivity solutions*

### ***Distance protection solution***

Distance protection devices are only used on long high voltage links (from several kilometers to 1,000 kilometers long). They are selective and do not require pilot wire links. The fault detection principle is based on the measurement of impedances.

These protection devices are very costly and are not used in industrial networks and rarely in public distribution medium voltage networks.

## 10.2. Busbar protection

Busbars can be protected by the logic selectivity system or by high impedance differential protection.

### 10.2.1. Protection of a busbar using logic selectivity (see Figure 10-20b)

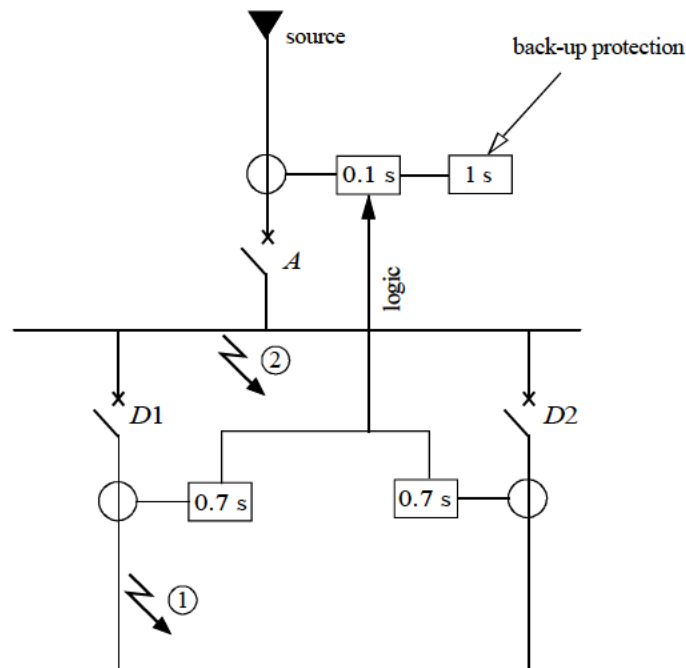


Figure 10-20b: protection of a busbar using logic selectivity

Logic selectivity is established between the incoming feeder *A* and outgoing feeders *D1* and *D2*. It is assumed that selectivity with the downstream protection devices requires a time delay of 0.7 seconds on the outgoing feeders.

The duration of the logic standby is limited to 200 ms after the outgoing feeder protection time delay. This enables the incoming feeder protection to operate as back-up if a downstream protection fails.

Back-up protection is positioned at *A* and is activated when the logic standby order does not function normally. Its time delay is set so as to obtain time-graded selectivity with the outgoing feeders (it is included in the Sepam logic system).

Fault at ①:

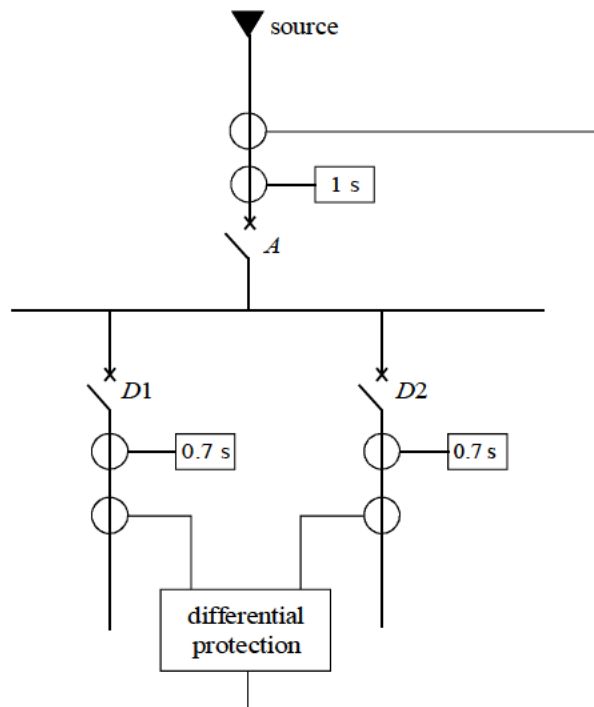
- The protection at *D1* sends a logic standby order to the protection at *A*.
- The circuit-breaker *D1* is tripped after its time delay of 0.7 seconds.
- If the protection at *D1* or the circuit-breaker *D1* fails, the protection at *A* is activated after the logic standby time is up, i.e. after  $0.7 + 0.2 = 0.9$  seconds .

Fault at ②:

- The circuit-breaker *A* is tripped after its time delay of 0.1 second.
- When the logic standby signal operates abnormally (spurious activation), the back-up protection is activated after its time delay of 1 second.
- This protection system is simple and not very costly.

For further details of the logic selectivity system, refer to section 9.3.

**10.2.2. Protection of a busbar using a high impedance differential protection (see Figure 10-20c)**



**Figure 10-20c: protection of a busbar using a high impedance differential protection**

The differential protection compares the current entering via the source to the sum of currents leaving via the outgoing feeders.

If the difference is zero, the busbar is healthy. If not, it is faulty.

The protection is activated instantaneously.

Time-delayed overcurrent protection is installed at  $A$  and will be activated when the differential protection fails.

It is assumed that selectivity with downstream protection devices requires a time delay of 0.7 seconds on the outgoing feeders.

The back-up protection at  $A$  is thus time-delayed by 1 second so that the time-graded selectivity interval is respected.

In order to make the protection system reliable, specific current transformers must be installed for the differential protection.

This protection system is fast-acting (instantaneous), but is, however, more costly than the logic selectivity system.

For further details on the operation of high impedance differential protection applied to busbars, refer to section 7.6.1.2.3.

### **10.3. Transformer protection**

We shall first of all study the transient currents that occur during transformer switching and the value of the LV short-circuit current detected by the HV side for a delta-star transformer. We shall then study the protection of transformers.

#### **10.3.1. Transformer energizing inrush current**

When the transformer is energized, a transient overcurrent is created, which depends on the moment that the voltage is applied and the remanent induction of the magnetic circuit.

The asymmetry and the current value are maximum when the transformer is energized, at the moment the voltage reaches zero, and when the remanent induction on the same phase is maximum.

The overcurrent is due to the saturation of the magnetic circuit, which causes a very high magnetizing current.

It is shown that:  $B_{\max} = 2B_n + B_r$

$B_{\max}$  : maximum induction reached

$B_n$  : nominal induction

$B_r$  : remanent induction which may reach  $0.8 B_n$

This overcurrent is referred to as an inrush current.

The inrush current thus develops as shown in Figure 10-21.

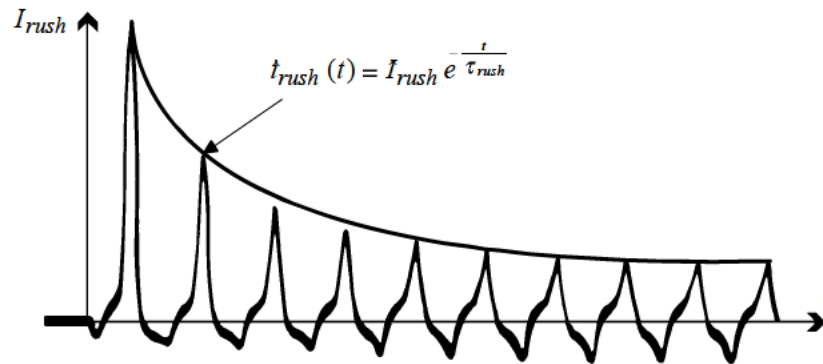


Figure 10-21: transformer energizing inrush current

The peak value of the inrush current is damped according to an exponential law:

$$\hat{i}_{rush}(t) = \hat{I}_{rush} e^{-\frac{t}{\tau_{rush}}}$$

$\hat{i}_{rush}(t)$  : peak value of the current in relation to time

$\hat{I}_{rush}$  : maximum peak value, i.e. the first peak

$\tau_{rush}$  : damping time constant



The maximum peak value  $\hat{I}_{rush}$  is defined in relation to the nominal r.m.s. current of the transformer:

$$n_{rush} = \frac{\hat{I}_{rush}}{I_n}$$

Tables 10-3 and 10-4 give the maximum values of the inrush currents and the damping time constants in relation to the power of the transformers for energization on the high voltage side (France Transfo transformers).

If the transformer is energized on the LV side, the ratio must be multiplied by 2 and the time constant divided by 1.5.

Note 1: when the inrush current curve is drawn for the selectivity study, the following value must be taken:

$$\frac{\hat{I}_{rush}(t)}{\sqrt{2}} \text{ (see Figure 10-28).}$$

Note 2: manufacturers generally supply the no-load inrush current value. Experience has shown that the on-load transformer inrush current value is roughly the same.

Power in kVA	100	160	250	315	400	500	630	800	1,000	1,250	1,600	2,000	2,500	3,150
$n_{rush} = \frac{\hat{I}_{rush}}{I_n}$	14	12	12	12	12	12	11	10	10	9	9	8	8	8
$\tau_{rush}$ in seconds	0.15	0.20	0.22	0.24	0.25	0.27	0.30	0.30	0.35	0.35	0.40	0.45	0.50	0.55

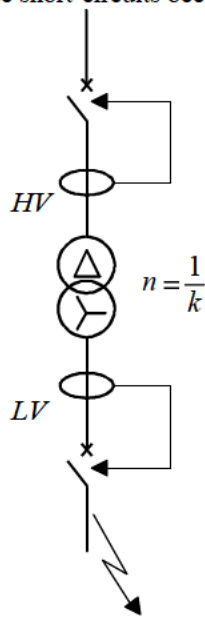
**Table 10-3:** inrush current on high voltage side of France Transfo liquid-insulated MV/LV transformers

Power in kVA	160	250	400	630	800	1,000	1,250	1,600	2,000
$n_{rush} = \frac{\hat{I}_{rush}}{I_n}$	10.5	10.5	10	10	10	10	10	10	9.5
$\tau_{rush}$ in seconds	0.13	0.18	0.25	0.26	0.30	0.30	0.35	0.40	0.40

**Table 10-4:** inrush current on high voltage side of France Transfo dry type MV/LV transformers

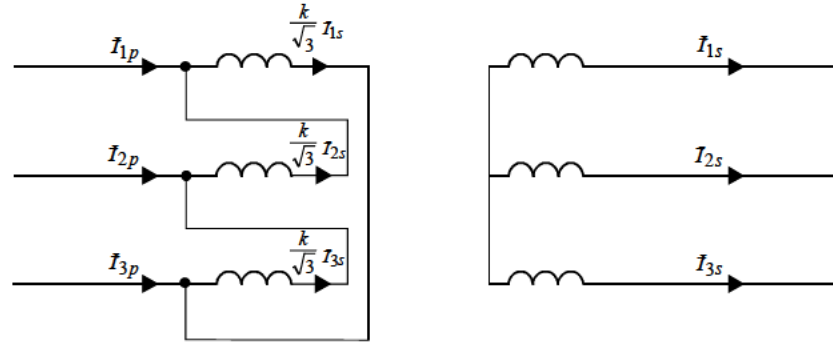
**10.3.2. Value of the short-circuit current detected by the HV side protection during a short-circuit on the LV side for a delta-star transformer**

Let us take a delta-star transformer with a transformation ratio of  $n = \frac{1}{k}$  (see Figure 10-22). We will determine the values of the primary currents for three-phase, phase-to-phase and neutral-phase short-circuits occurring on the secondary side.



**Figure 10-22:** delta-star transformer with a transformation ratio of  $n = \frac{1}{k}$

*Current in lines and branches of a delta-star transformer (see Figure 10-23)*



**Figure 10-23:** current in lines and branches of a delta-star transformer

The transformation ratio is  $n = \frac{1}{k}$ . However, owing to the delta-star connection, the ratio of the number of turns between primary and secondary windings is equal to  $n\sqrt{3} = \frac{\sqrt{3}}{k}$ .

Let  $I$  be the amplitude of the secondary current:

$$I_{1s} = I_{2s} = I_{3s} = I$$

In Figure 10-23, we see that:

$$\begin{cases} \vec{I}_{1p} = \frac{k}{\sqrt{3}} (\vec{I}_{1s} - \vec{I}_{2s}) \\ \vec{I}_{2p} = \frac{k}{\sqrt{3}} (\vec{I}_{2s} - \vec{I}_{3s}) \\ \vec{I}_{3p} = \frac{k}{\sqrt{3}} (\vec{I}_{3s} - \vec{I}_{1s}) \end{cases}$$

Now:

$$|\vec{I}_{1s} - \vec{I}_{2s}| = \sqrt{3} I$$

$$|\vec{I}_{2s} - \vec{I}_{3s}| = \sqrt{3} I$$

$$|\vec{I}_{3s} - \vec{I}_{1s}| = \sqrt{3} I$$

Hence:  $I_{1p} = I_{2p} = I_{3p} = k I$

**Determining the primary current values for a three-phase short-circuit on the secondary**

$$I_{1s} = I_{2s} = I_{3s} = \frac{V_n}{Z} \quad (\text{see section 4.2.1})$$

$$I_{1p} = I_{2p} = I_{3p} = k \frac{V_s}{Z} = I_{sc3, HV}$$

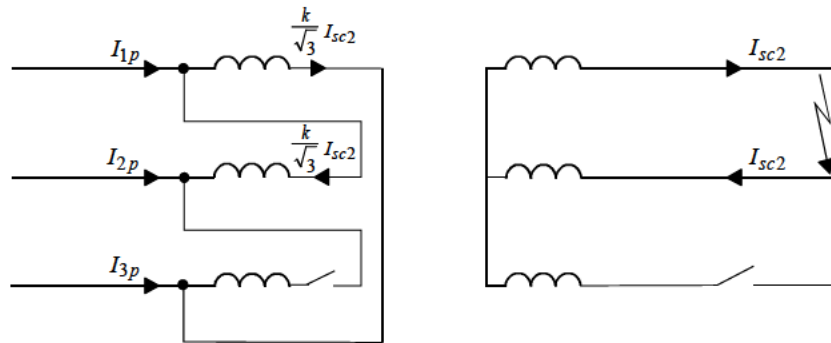
$I_{sc3, HV}$  : HV side three-phase short-circuit current

$V_s$  : single-phase voltage at the secondary

$Z$  : positive-sequence impedance of the network upstream of the short-circuit detected by the secondary

**Determining the primary current values for a phase-to-phase short-circuit on the secondary between phases 1 and 2**

The equivalent diagram is shown in Figure 10-24.



**Figure 10-24:** equivalent diagram of a delta-star transformer during a phase-to-phase short-circuit

According to section 4.2.3:

$$I_{sc2} = \frac{\sqrt{3} V_s}{2 Z}$$

$I_{sc2}$  : LV side phase-to-phase short-circuit current

$V_s$  : single-phase voltage at the secondary

$Z$  : positive-sequence impedance of the network upstream of the short-circuit detected by the secondary

In Figure 10-24 we can see that:

$$I_{1p} = \frac{2k}{\sqrt{3}} I_{sc2}$$

$$I_{2p} = -\frac{k}{\sqrt{3}} I_{sc2}$$

$$I_{3p} = -\frac{k}{\sqrt{3}} I_{sc2}$$

i.e.:

$$I_{1p} = \frac{k V_s}{Z} = I_{sc3,HV}$$

$$I_{2p} = -\frac{k V_s}{2 Z} = -\frac{I_{sc3,HV}}{2}$$

$$I_{3p} = -\frac{k V_s}{2 Z} = -\frac{I_{sc3,HV}}{2}$$

***Determining the primary current values for a phase-to-neutral short-circuit on phase 1***

The equivalent diagram is shown in Figure 10-25.

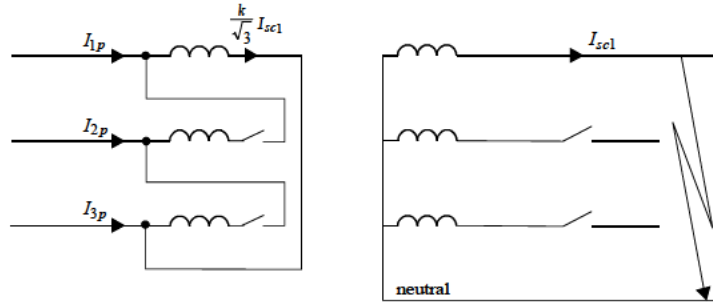


Figure 10-25: equivalent diagram of a delta-star transformer during a phase-to-neutral short-circuit

According to section 4.4.1.1:

$$I_{sc1} = \frac{V_s}{(Z + Z_{neut})}$$

$V_s$  : single-phase voltage at the secondary

$Z_{neut}$  : impedance of the neutral circuit through which the fault current flows

$Z$  : positive-sequence impedance of the network upstream of the short-circuit detected by the secondary

In Figure 10-25 we see that:

$$I_{1p} = \frac{k}{\sqrt{3}} I_{sc1}$$

$$I_{2p} = 0$$

$$I_{3p} = -\frac{k}{\sqrt{3}} I_{sc1}$$

i.e.:

$$I_{1p} = \frac{k}{\sqrt{3}} \frac{V_s}{(Z + Z_{neut})} = \frac{1}{\sqrt{3}} \frac{Z}{(Z + Z_{neut})} I_{sc3,HV}$$

$$I_{2p} = 0$$

$$I_{3p} = -\frac{k}{\sqrt{3}} I_{sc1} = -\frac{1}{\sqrt{3}} \frac{Z}{(Z + Z_{neut})} I_{sc3,HV}$$

**Summary**

Table 10-5a summarizes the HV side current value calculations for three-phase, phase-to-phase and phase-to-neutral short-circuits on the LV side.

	<b>Phase 1</b>	<b>Phase 2</b>	<b>Phase 3</b>
Three-phase short-circuit	$I_{sc3,HV}$	$I_{sc3,HV}$	$I_{sc3,HV}$
Phase-to-phase short-circuit between phases 1 and 2	$I_{sc3,HV}$	$-\frac{1}{2} I_{sc3,HV}$	$-\frac{1}{2} I_{sc3,HV}$
Phase-to-neutral short-circuit on phase 1	$\frac{-Z}{(Z + Z_{neut})} \frac{1}{\sqrt{3}} I_{sc3,HV}$	0	$\frac{Z}{(Z + Z_{neut})} \frac{1}{\sqrt{3}} I_{sc3,HV}$

**Table 10-5a:** value of the HV side current during an LV side short-circuit for a delta-star transformer

Table 10-5a can be used to determine the HV side minimum and maximum short-circuit currents for an LV side short-circuit. The values indicated are valid whatever the transformation ratio.

It is necessary to know these values in order to determine the setting thresholds of a transformer's HV protection:

- in order to protect the transformer against a short-circuit occurring directly at its downstream terminals or when the HV protection must act as back-up to the LV protection. In this case, the minimum short-circuit current must be known;
- when the protection must be selective (of the amperometric type) with the LV protection. In this case, the maximum short-circuit current must be known.

Note: when only the HV protection monitors two phases (phases 2 and 3 in our example), the minimum short-circuit current detected by the HV protection

$$\left( I_{sc, \min, LVHV} \right) \text{ is } \frac{1}{2} I_{sc3, HV}.$$

### 10.3.3. *Faults in transformers*

The main faults that may affect a transformer are:

- overload;
- phase short-circuit (internal or external);
- earth fault.

#### ***Overload***

Most of the time, this is due to an increase in the number of simultaneously fed loads or an increase in the power demand for one or more loads.

This causes an overcurrent of long duration, which causes a rise in temperature that is prejudicial to the withstand of insulators and the longevity of the transformer.

#### ***Phase short-circuit***

This may occur inside or outside a transformer:

– Internal: this is a fault between conductors with different phases or more often between the turns of the same winding. In an oil-insulated transformer, the arc causes a decomposition gas to be emitted from the liquid dielectric. If the fault is weak, a small amount of gas is discharged that, when accumulated, becomes dangerous. A strong short-circuit causes considerable damage that may destroy the coils, and also the tank if the fire on oil spreads. This gas causes an overpressure, which may lead to the destruction of the tank and effusion of oil with a risk of fire.

– External: this is a phase-to-phase fault in the downstream links. The short-circuit current causes electrodynamic effects in the transformer that may mechanically affect the coils and transform the short-circuit into an internal type of fault.

#### ***Earth fault***

The earth fault is an internal fault. It may occur between the coils and tank or between the coils and magnetic core. For an oil-insulated transformer, it causes a gaseous discharge. Like the internal short-circuit, it may cause the destruction of the tank and a fire.

The amplitude of the fault current depends on the earthing system of the upstream and downstream networks. For the fault current not to be close to zero, the zero-sequence impedance detected by the fault point must not be infinite (see Table 4-16). The amplitude of the fault current also depends on the setting of the fault in the coils (see section 10.1.1).



#### **10.3.4. Transformer protection**

This includes any type of transformer (except specific transformers for welding machines, arc furnaces, etc.).

##### *10.3.4.1. Specific protection against overloads*

This is ensured in one of the following ways:

- by monitoring the temperature of the dielectric for liquid-insulated transformers (see section 7.23); the alarm threshold is generally set at 80°C. The off-loading or switch-off threshold of the transformer is generally set at 90°C;
- by monitoring the temperature of the windings for dry type transformers (see section 7.23), using a thermal probe that detects an abnormal rise in temperature;
- by a long time-delayed trip relay on the circuit-breaker installed on the low voltage side;
- by thermal overload protection (see section 7.7).

We can note that fuses and overcurrent protection devices do not protect against overload.

Note: when the load specifications being fed exclude the possibility of overload, protection against overloads is not necessary.

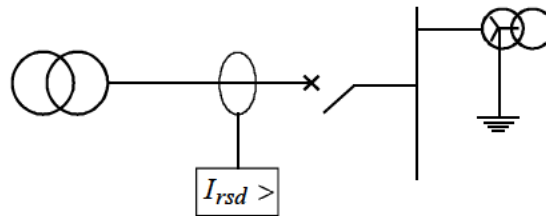
##### *10.3.4.2. Specific protection against internal phase short-circuits*

- *for liquid-insulated transformers*: using a gas and pressure detector (see DGPT section 7.25) which is sensitive to a discharge of gas caused by a short-circuit. This type of protection is recommended for transformers with a power above 630 kVA.
- *using transformer differential protection* (see section 7.6.3).

##### *10.3.4.3. Specific protection against earth faults*

This can be ensured in one of the following ways:

- by protection against tank earth leakage faults (see section 7.20);
- by earth fault protection (see section 7.2) located on the upstream network for a frame-earth fault affecting the transformer primary;
- by earth fault protection located on the neutral earthing connection of a transformer with a star-connected secondary, for a frame-earth fault affecting the transformer secondary;
- by earth fault protection located on the incoming busbar (see section 2.3.1) fed by the transformer if neutral earthing is made with an artificial neutral (see Figure 10-26);
- by restricted earth fault differential protection (see section 7.6.1.2.4).



**Figure 10-26:** protection against transformer earth faults when earthing is on the downstream busbar

Note: if there is no earthing on the transformer, biased transformer differential protection (see section 7.6.3) may be used to detect earth faults. The biased protection must, however, be sufficiently sensitive. This is not always the case, especially when the earth fault current is limited by an impedance.

#### 10.3.4.4. Switch-fuse protection

To determine the fuse rating, the selection tables in equipment operating guides are generally referred to (see, for example, Table 10-5c for the Schneider SM6).

For cases which do not correspond to the standard selection tables, the rules and criteria indicated below must be respected when choosing the fuse rating.

#### **Rated fuse voltage**

The rated fuse voltage  $U_{nf}$  must be higher than or equal to the network operating voltage ( $U_n$ ):

$$U_{nf} \geq U_n$$

Note: a fuse with a rated voltage that is too high will, if fused, cause excessive overvoltages on the network.

#### **Maximum breaking capacity of the fuse**

The maximum breaking capacity of the fuse  $I_1$  (see section 8.4) must be higher than the maximum short-circuit current of the upstream network  $I_{scup}$ :

$$I_1 \geq I_{scup}$$

#### **Short-circuit current on the transformer secondary**

The short-circuit current of a symmetrical three-phase fault  $I_{sc3}$  on the secondary must be higher than the minimum breaking current of the fuse  $I_3$  (see section 8.4):

$$I_{sc3} \geq I_3$$

$$100 \times \frac{I_b}{U_{sc} (\%)} \geq I_3$$

$I_b$  : transformer basic current (or nominal current)

$U_{sc} (\%)$  : transformer short-circuit current (see section 4.2.1.3)

### **Installation conditions**

The thermal power diffused by the fuse during steady-state operating conditions must respect the maximum heating limits of the fuse environment.

For example, for the Schneider SM6 the cold resistance  $R_c$  must satisfy the following requirement:

$$\begin{aligned} 1.9 R_c I_b^2 &< 100 W && \text{for an ambient temperature } < 40^\circ\text{C} \\ &< 80 W && \text{for an ambient temperature } 40^\circ\text{C} < T < 55^\circ\text{C} \end{aligned}$$

1.9: coefficient taking into account the specifications of the SM6 cubicle and obtained after tests

$I_b$  : transformer basic current (or nominal current)

### **Transformer short-time overloads**

So as not to alter the fuse, the following condition must be satisfied:

$$I_{nf} \geq 1.4 I_b$$

$I_{nf}$  : rated fuse current

### **Operation with permanent overload**

If the transformer is designed to operate with a permanent overload (for several hours), the following condition must be satisfied:

$$I_{nf} \geq 1.3 I_{ol} \quad I_{ol} : \text{overload current}$$

### **Transformer energizing inrush current (see section 10.3.1)**

In accordance with IEC 60787, the following condition must be satisfied: the point defined by  $t = 0.1s$  and  $I = 10$  to  $12$  times the transformer nominal current is located under the fusing curve.

**Co-ordination between the fuses and the breaking capacity of the switch for combined fuse-switch cubicles (in compliance with IEC 62271-105, section 8.2.4)**

The fuses of combined fuse-switch cubicles are fitted with strikers which, when one or more fuses are fused, cause the switch to open, thus preventing single-phase or phase-to-phase operation.

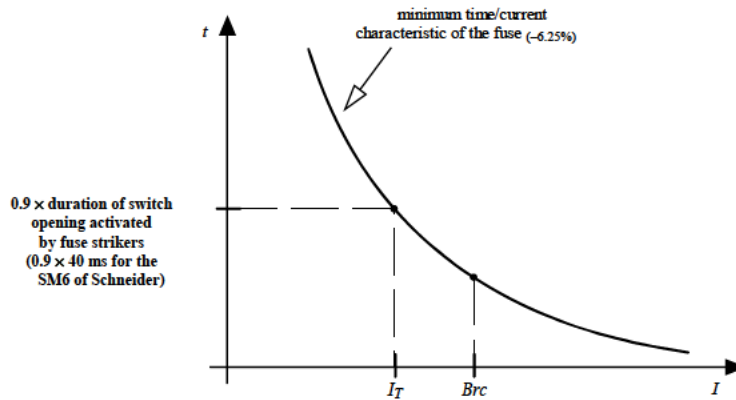
Upon occurrence of a three-phase short-circuit, the fastest-acting fuse melts, thus breaking the first phase. A reduced current then flows through the two other phases (0.87 times the three-phase current: see section 4.2.3) which will be interrupted either by the switch (via the strikers) or by the two other fuses.

IEC 62271-105 defines the transfer current  $I_T$ , obtained when the switch is opened and the two fuses are fused simultaneously.

For a current lower than the transfer current, the switch takes over from the fuses, which thus defines its minimum breaking capacity.

From a practical point of view, the transfer current is determined by superimposing a time equal to 0.9 times the duration of switch opening caused by the fuses (via the strikers), on the minimum time/current characteristic (based on a current tolerance of -6.5%).

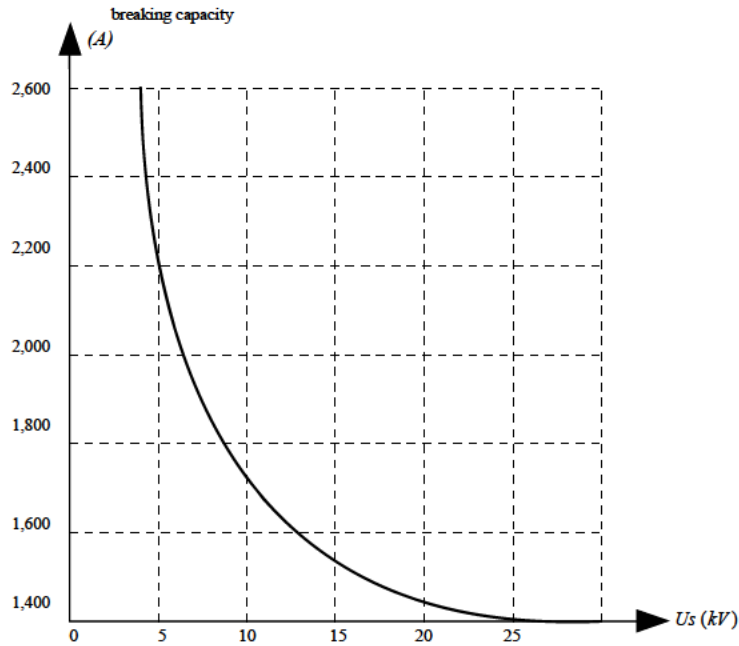
The switch breaking capacity must be higher than or equal to the transfer current (see Figure 10-27a):  $Brc \geq I_T$



$Brc$  : switch breaking capacity  
 $I_T$  : transfer current

**Figure 10-27a: co-ordination between the fuses and the breaking capacity of the switch**

For example, the breaking capacity of the switch in a Schneider SM6 cubicle, in relation to the operating voltage, is that shown in Figure 10-27b. We can note that it is a matter of short-circuit breaking capacity and it is thus defined for a  $\cos \varphi = 0.2$ .



**Figure 10-27b:** breaking capacity of Schneider SM6 switch cubicle for ( $\cos \varphi = 0.2$ )

***Transient recovery voltage upon occurrence of a fault at the secondary terminals of the transformer (in accordance with IEC 62271-105, section 8.2.6)***

Upon occurrence of a solid short-circuit at the secondary terminals of the transformer, the fuse which breaks a pole first creates high transient recovery voltages on the other poles. The switch would not be able to break these poles with such transient voltages.

The fuses must therefore be chosen so that they alone clear such a fault without causing the switch to operate.

In practice, this condition requires that the previously defined transient current  $I_T$  (see Figure 10-27a) be lower than the short-circuit current detected by the primary:

$$I_T < I_{sc3}$$

$$I_T < 100 \times \frac{I_b}{U_{sc}(\%)}$$

Note 1: it is sometimes difficult to obtain this condition, which may mean that it is impossible to use a fuse-switch when aiming to respect IEC 62271-105.

Note 2: when this condition is satisfied, the condition  $I_{sc3} \geq I_3$  is also fulfilled because  $I_T > I_3$ .

**Example of rating fuse determination of combined fuse-switch**

Let us consider a power transformer of  $S = 315 \text{ kVA}$  with a phase-to-phase voltage of  $U_n = 20 \text{ kV}$  protected with a Schneider SM6 cubicle. The selected type is Fusarc 24 kV. Table 10-5b and Figure 10-27c show that a Fusarc 25 A fuse is suitable.

	$I_b$	$I_{nf}$	$I_3$	$12 I_b$	$I_T$	$I_{sc3}$	$Brc$
Transformer	9.1 A			1,089 $\hat{A}$		227 A	
Fusarc		25 A	82 A		190 A		
Switch							1,450 A
Source	$\frac{S}{\sqrt{3} U_n}$		see Figure 10-27c	see Table 10-3	see Figure 10-27c	see Table 4-10	see Figure 10-27b

**Table 10-5b:** 315 kVA transformer,  $U_n = 20 \text{ kV}$ , protected by a Fusarc 25 A fuse

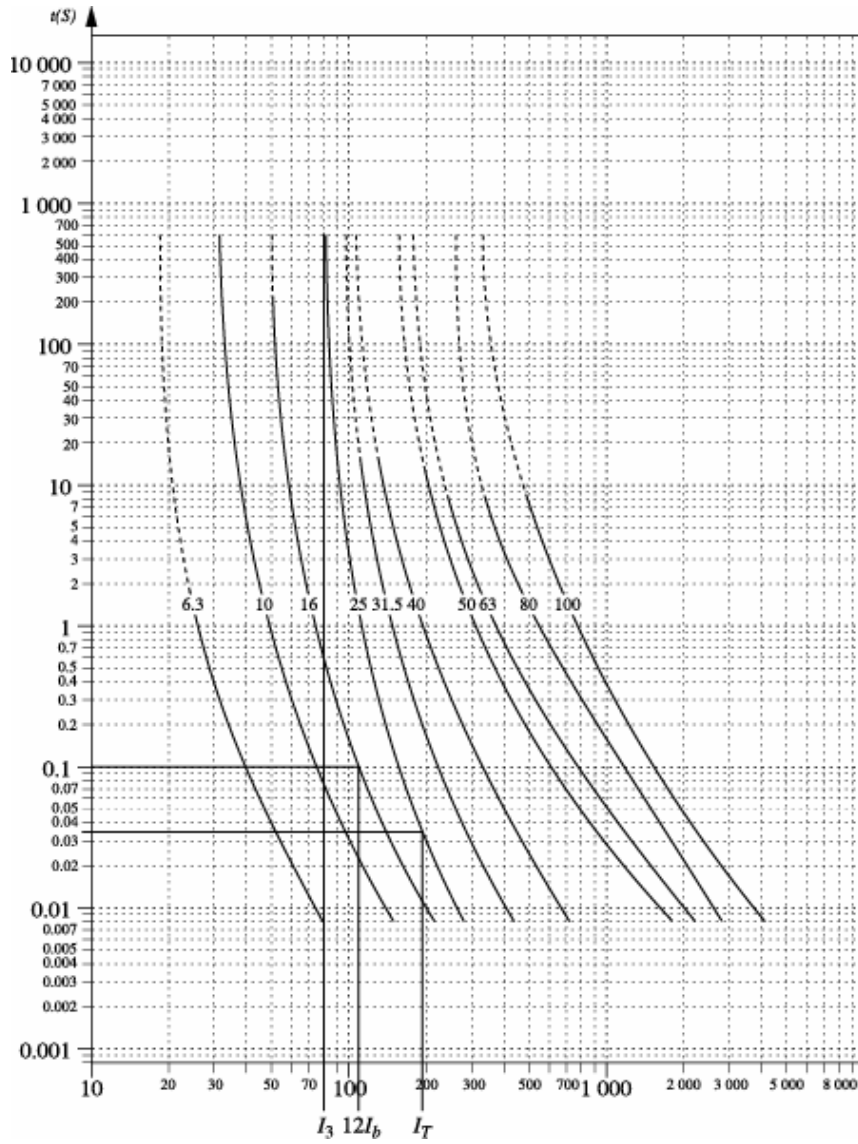


Figure 10-27c: fusing curve – 24 kV internal Fusarc fuse

**Example of fuse selection table for the Schneider SM6 cubicle**

Table 10-5c provides means of selection of Soléfuse and Fusarc fuse ratings for the SM6 for use without overload at  $-5^{\circ}\text{C} < T < 40^{\circ}\text{C}$ .

The fuses selected comply with the aforementioned conditions.

Type of fuse	Oper. voltage (kV)	Transformer power (kVA)															Rated voltage (kV)				
		25	50	100	125	160	200	250	315	400	500	630	800	1,000	1,250	1,600		2,000	2,500		
<b>S</b>	3.3	16	16	16	31.5	31.5	63	63	100	100										7.2	
	5.5	6.3	16	16	31.5	31.5	63	63	63	80	100	125									
	6.6	6.3	16	16	16	31.5	31.5	43	43	63	80	125									
	10	6.3	6.3	16	16	16	31.5	31.5	31.5	43	43	63	80	100						12	
	13.8	6.3	6.3	6.3	16	16	16	16	16	31.5	31.5	43	63	80						17.5	
<b>u</b>	15	6.3	6.3	16	16	16	16	16	31.5	31.5	43	43	63	80							
	20	6.3	6.3	6.3	6.3	16	16	16	16	31.5	31.5	43	43	63						24	
	22	6.3	6.3	6.3	6.3	16	16	16	16	16	31.5	31.5	43	63							
<b>F</b>	3.3	16	25	40	50	50	63	80	80	125*										7.2	
	5.5	10	16	25	31.5	31.5	40	50	63	80	100	125	160*								
	6.6	10	16	25	31.5	31.5	40	50	50	63	80	100	125	160							
	10	6.3	6.3	16	16	25	25	31.5	40	50	63	80	100	160	200					12	
	13.8	6.3	6.3	10	16	16	16	25	25	31.5	40	50	63	80	125	160				24	
	15	6.3	6.3	10	16	16	16	25	25	31.5	40	50	63	80	100	125	160				
	20	6.3	6.3	10	10	16	16	16	25	25	31.5	31.5	40	50	80	100	125				
22	6.3	6.3	10	10	10	16	16	16	25	25	31.5	31.5	40	50	63	80	100				

**Table 10-5c:** selection of Soléfuse and Fusarc type fuses for the Schneider SM6 Rating in A – use without overload at  $-5^{\circ}\text{C} < T < 40^{\circ}\text{C}$



#### 10.3.4.5. *Circuit-breaker protection*

This type of protection is recommended when the basic transformer current rises above 125 A.

The inrush currents due to transformer energizing must not cause the circuit-breaker to be tripped.

The circuit-breaker can be fitted with a single threshold or rather with a double threshold independent time phase overcurrent protection.

##### ***Single threshold independent time protection***

The setting threshold  $I_{set}$  must be such that the minimum HV short-circuit current (see section 4.4.2) causes the circuit-breaker to be tripped, i.e.  $I_{set} \leq 0.8 I_{sc, \min}$ .

Experience has shown that the following setting requirements can be used to avoid spurious tripping:

- $I_{set} > 5 I_b$ : transformer basic current (or nominal current)
- time delay = 0.2 seconds

The condition  $5 I_b < 0.8 I_{sc2, \min}$  is normally satisfied. If it is not, a more detailed study must be carried out in order to find the best compromise between totally selective protection and the risk of spurious tripping during energization, or installing double threshold protection.

Single threshold protection does not protect the transformer against short-circuits coming directly from its downstream terminals. It cannot act as back-up to the LV protection. This is why it is advisable to install a double threshold protection which overcomes this drawback.

##### ***Double threshold independent time protection***

Let us consider the schema of Figure 10-27d.

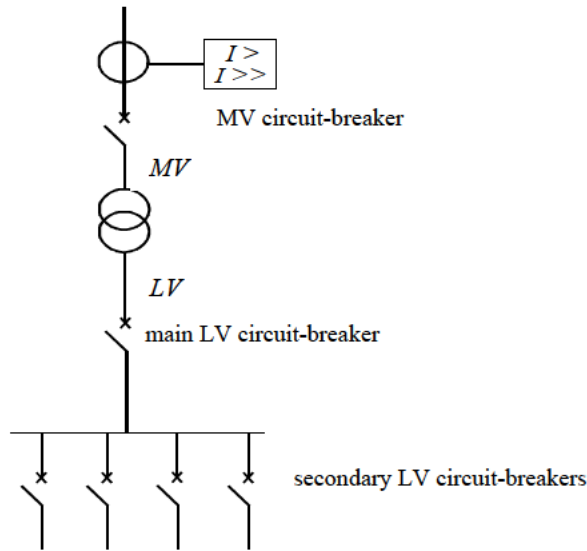


Figure 10-27d: double threshold independent time protection

The MV circuit-breaker is equipped with a double threshold independent time protection. Selectivity between MV circuit-breaker and main LV circuit-breaker is not useful. On the other hand, it is extremely worthwhile to obtain selectivity between MV circuit-breakers and secondary LV circuit-breakers.

#### High threshold

This protects against HV side short-circuits inside the transformer.

Selectivity with the LV circuit-breaker is of the amperemetric type (see section 9.1).

The high threshold  $I_{hset,HV}$  must be set such that the HV minimum short-circuit current (see section 4.4.2) causes the circuit-breaker to be tripped. The protection must be checked to make sure that it is not activated during transformer energizing. The time delay must be zero in order to avoid any risk of explosion upon a very high current short-circuit.

These conditions require the high threshold to comply with the following relation:

$$1.25 I_{sc,max,LV} \leq I_{hset,HV} \leq 0.8 I_{sc2,min,HV}$$

$$I_{hset,HV} \geq 1.2 \frac{\hat{I}_{rush}}{\sqrt{2}} I^{-\frac{t_h}{\tau_{rush}}}$$

$t_h = 0$  (in practice, the minimal activation time of the protection, i.e. 10 to 20 ms)

The values of the inrush currents  $\hat{I}_{rush}$  and time constants  $\tau_{rush}$  are given in Tables 10-3 and 10-4.

### **Low threshold**

This protects against LV side short-circuits:

- at the downstream terminals of the transformer or on the main LV circuit-breaker;
- as back-up to the main LV circuit-breaker.

Selectivity with the secondary LV circuit-breakers is time-graded (see section 9.2).

The low threshold  $I_{lset,HV}$  must be lower than the minimum value of the current detected by the HV protection upon occurrence of an LV short-circuit, i.e.  $I_{sc,min,LVHV}$ . In the case of a delta-star transformer, see section 10.3.2 for determining  $I_{sc,min,LVHV}$ . It must be higher than transient currents due to motor start-up currents or higher than pick-up currents following the fault clearance on the network. The protection must be checked to make sure that it is not activated during transformer energizing.

These conditions require the low threshold to comply with the following relations:

$$1.25 I_{set,LV} \leq I_{lset,HV} \leq 0.8 I_{sc,min,LVHV}$$

$$t_l \geq t_{LV} + \Delta t$$

$$I_{lset,HV} \geq 1.2 \frac{\hat{I}_{rush}}{\sqrt{2}} I^{-\frac{t_b}{\tau_{rush}}}$$

$$I_{lset,HV} \geq 1.2 I_{Tr}$$

The inrush current values  $\hat{I}_{rush}$  and time constants  $\tau_{rush}$  are given in Tables 10-3 and 10-4.

Figure 10-28 illustrates the operating conditions of the double threshold protection.

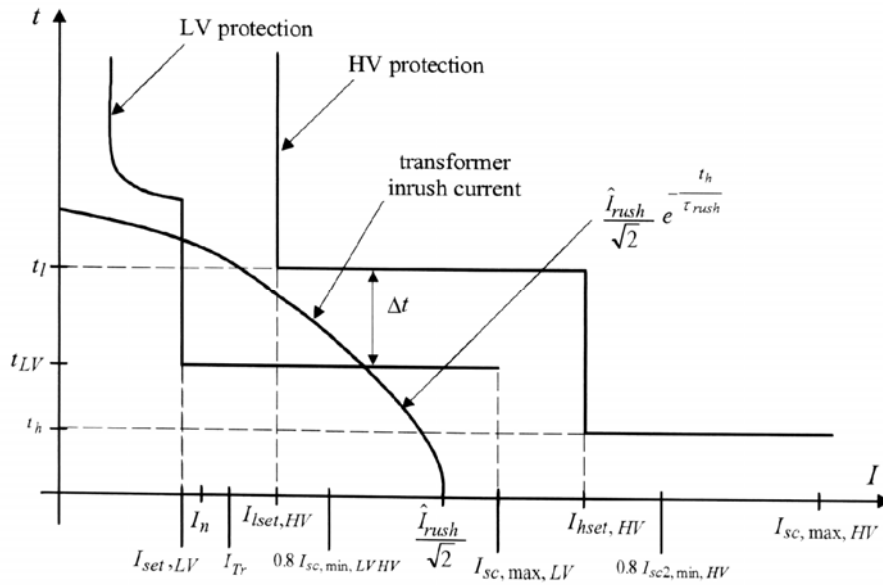


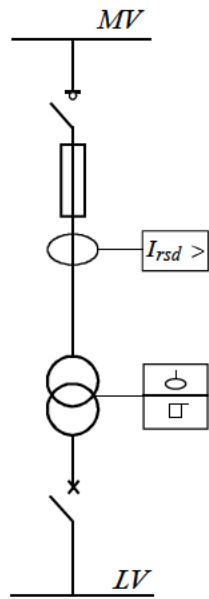
Figure 10-28: double threshold protection of a transformer

- $I_n$  : transformer nominal current
- $I_{set,LV}$  : secondary LV circuit-breakers protection setting threshold (short delay)
- $I_{set,HV}$  : low threshold of the HV circuit-breaker protection
- $I_{sc,max,LV}$  : maximum LV short-circuit current
- $\hat{I}_{rush}$  : transformer inrush current (1<sup>st</sup> peak value)
- $I_{hset,HV}$  : high threshold of the HV circuit-breaker protection
- $I_{sc2,min,HV}$  : minimum phase-to-phase HV short-circuit current
- $I_{sc,max,HV}$  : maximum HV short-circuit current
- $t_h$  : HV protection high threshold time delay

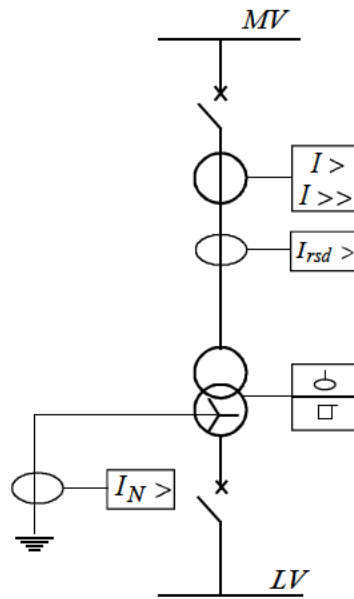
- $t_l$  : HV protection low threshold time delay
- $t_{LV}$  : secondary LV circuit-breakers protection time delay
- $\hat{I}_{rush} I^{-\frac{t_h}{\tau_{rush}}}$  : value of the peak inrush current of the transformer at  $t = t_h$
- $I_{sc,min,LVHV}$  : minimum current value detected by the HV protection during an LV short-circuit
- $I_{Tr}$  : maximum transient current

**10.3.5. Examples of transformer protection**

*MV/LV transformers (see Figures 10-29 and 10-30)*

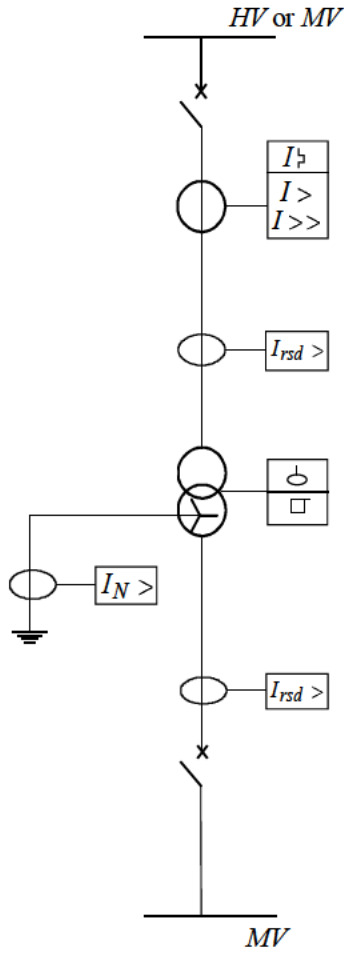


**Figure 10-29:** protection of a low power MV/LV transformer

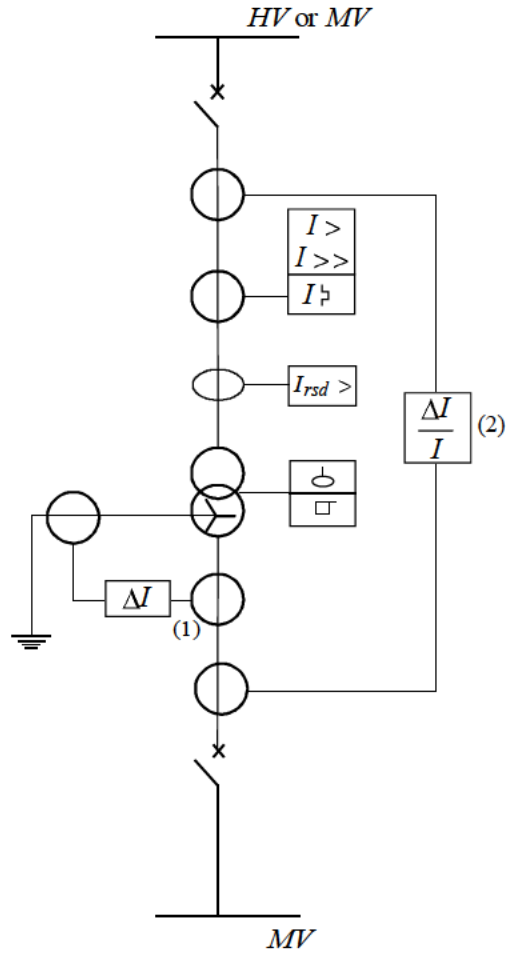


**Figure 10-30:** protection of a high power MV/LV transformer

*MV/MV or HV/MV transformers (see Figures 10-31 and 10-32)*



**Figure 10-31:** protection of a low power MV/MV or HV/MV transformer



**Figure 10-32:** protection of a high power MV/MV or HV/MV transformer

- (1) restricted earth fault differential protection (see section 7.6.1.2.4)
- (2) transformer differential protection (see section 7.6.3)

**10.3.6. Transformer protection setting indications (see Table 10-6)**

Type of fault	Settings
<b>Overload</b>	<p><b>Low voltage circuit-breaker:</b> thermal threshold <math>&gt; 1.2 I_n</math></p> <p><b>Thermal overload:</b> <math>H_{set} = 120\%</math></p> <p>Time constant: depends on transformer size and type (dry or liquid-insulated) e.g. roughly 3 hours for a 400 kVA liquid-insulated</p> <p><b>Dielectric temperature monitoring for liquid-insulated transformers (O1 class):</b>  Alarm threshold 8,095°C  Off-load or switch off threshold 10,090°C</p> <p><b>Winding temperature monitoring for dry type transformers:</b>  The thresholds are different depending on the transformer thermal class and manufacturer. For France Transfo TRIHAL (F class) they are not adjustable:  alarm threshold 150°C  off-load or switch off threshold 160°C</p>
<b>External phase short-circuit</b>	<p><b>Fuse:</b> see Table 10-5b for transformers protected by a Schneider SM6 type cubicle</p> <p><b>Circuit-breakers:</b></p> <p><b>double threshold independent time protection</b>  high threshold:  <math>1.25 I_{sc, \max, LV} \leq I_{hset}, HV \leq 0.8 I_{sc2, \min, HV}</math>  time = 0.1 second (in practice 10 to 20 ms)</p> <p>low threshold:  <math>I_{set, LV} \leq I_{lset}, HV \leq 0.8 I_{sc, \min, LVHV}</math>  time delay <math>\geq t_{LV} + \Delta t</math>  See section 10.3.4.5 for other characteristics</p> <p><b>single threshold independent time protection</b>  <math>I_{set, HV} = \min(5 I_b ; 0.8 I_{sc2, \min})</math>  time delay = 0.2 seconds</p>

	Settings
<b>Internal phase short-circuit</b>	<p><b>Biased differential protection</b></p> <p>Without on-load tap-changer regulator: 15% percentage characteristic – minimum operating threshold 30% of <math>I_n</math></p> <p>With on-load tap-changer regulator: 30% percentage characteristic – minimum operating threshold 30% of <math>I_n</math></p>
<b>Earth fault</b>	<p>– <b>Tank earth leakage frame</b>  Threshold = 20 A  Or threshold = <math>0.3I_\ell</math> (if <math>0.3I_\ell &lt; 20A</math>)  Short, if not zero, time delay  (<math>I_\ell</math> earth fault limiting current)</p> <p>– <b>Earth fault protection located on the upstream network</b>  Threshold &lt; 10% of the maximum earth fault current (protects 90% of the windings of a star transformer: see section 10.1.1) and higher than minimum threshold &gt; 12% of the CT rating if measurement by 3 CTs (see section 10.1.1)</p> <p>The time delay depends on the selectivity system</p> <p>– <b>Restricted earth fault differential protection</b>  Threshold approximately 10% of <math>I_n</math>  No time delay</p>

Table 10-6: transformer protection setting indications

#### 10.4. Motor protection

Motor protection is provided by the set of devices ensuring that deterioration due to abnormal supply, motor or load operating conditions is avoided.

##### *Main faults affecting an asynchronous motor*

- overload;
- internal or external phase short-circuits;
- phase cutting, inversion of two phases and phase unbalance;
- stator frame fault;
- excessive start-up time and locked rotor;
- drop in supply voltage;



- closing of the switching device while motors still hold a considerable remanent voltage;
- too many successive start-ups;
- drop in current;
- rotor frame fault (for slipping rotor motors).

***Main faults affecting a synchronous motor***

To the faults listed for asynchronous motors may be added:

- loss of synchronism;
- loss of excitation;
- rotor frame fault;
- prolonged asynchronous operation upon start-up;
- overload and short-circuit in excitation windings;
- generator operation.

**10.4.1. Protection of medium voltage motors**

***Protection against overloads***

These are revealed by the occurrence of overcurrents which, if prolonged, cause excessive heating leading to accelerated ageing of the motor.

Protection is ensured by the following methods:

- either by a thermal overload protection (see section 7.7);
- or by a temperature monitoring device (see section 7.23).

***Protection against internal or external phase short-circuits***

External faults may occur at the terminals or in the power cable between the switchboard and motor. Internal faults may occur between two turns of the same phase or different phases following the deterioration of the insulators. They produce considerable phase-to-phase overcurrents.

Protection may be ensured by the following methods:

- By independent time phase overcurrent protection devices for equipment with circuit-breaker.

The current threshold must be set above the starting current, e.g.  $I_{set} = 1.3 I_{st}$ , with a time delay of roughly 0.1 second.

– Using high impedance differential protection for internal short-circuits (see section 7.6.1.2.1).

This type of protection is only used for motors above roughly 2 MW.

– Using biased differential protection.

This type of protection is only used for motors above roughly 2 MW.

– By fuse for equipment with contactor + fuse.

It must be remembered that fuses protect a motor against overcurrents above the starting current and do not therefore provide protection against overloads.

The rating of fuses is determined in relation to the:

- nominal current  $I_n$  ;
- starting current  $I_{st}$  ;
- start-up time  $T_{st}$  ;
- maximum number of start-ups per hour;
- maximum number of successive start-ups.

#### **Method for determining fuse rating**

The virtual starting current  $I_{vi}$  is determined by applying multiplier coefficients from numerous tests carried out:

$$I_{vi} = I_{st} \times 2 \times k$$

–  $k = 1.2$ , if the motor starting current is the design value given by the manufacturer, since this value is given with a 20% error margin, in compliance with standards.

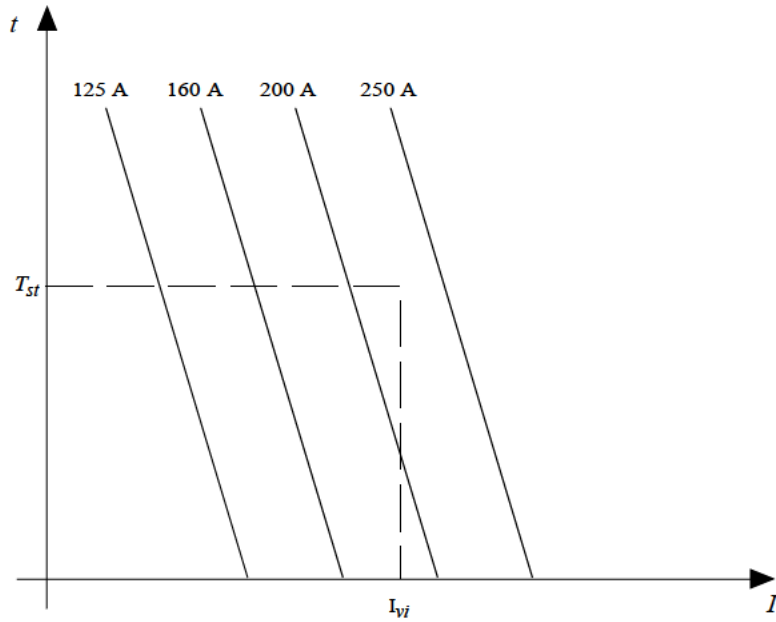
–  $k = 1$ , if the starting current value is from a measurement.

The point corresponding to the virtual current  $I_{vi}$  and start-up time  $T_{st}$  is transcribed on to the fuse fusing curves (see Figure 10-33).

The rating chosen is the value immediately to the right of this point.

In Figure 10-33, the rating to be used is 250 A.

This method of determination can be used to guarantee that the fuse does not deteriorate for a number of start-ups per hour less than or equal to 6 and a number of successive start-ups lower than or equal to 2.



**Figure 10-33:** *determination of the motor protection fuse*

If the number of start-ups per hour is more than 6, or the number of successive start-ups is more than 2, the method described below is applied as it determines the excess fuse rating.

*Number of start-ups per hour above 6*

A virtual start-up time  $T_{vih}$  is determined such that:

$$T_{vih} = \frac{N_h}{6} T_{st}$$

$N_h$  : maximum number of start-ups per hour

In order to determine the fuse rating,  $T_{vih}$  is transcribed on to the fuse fusing curves in place of  $T_{st}$ .

*Number of successive start-ups above 2*

The virtual start-up time  $T_{vist}$  is determined such that:

$$T_{vist} = \frac{N_s}{2} T_{st}$$

$N_s$  : maximum number of successive start-ups

In order to determine the fuse rating,  $T_{vist}$  is transcribed on to the fuse fusing curves in place of  $T_{st}$ .

*Number of start-ups per hour above 6 and number of successive start-ups above 2*

In order to determine the fuse rating, the maximum value between  $T_{vih}$  and  $T_{vist}$  is transcribed on to the fuse fusing curves in place of  $T_{st}$ .

*When the motor start up is not direct (electronic starter, auto-transformer, etc.) the starting current may be fairly low, e.g.  $3 I_n$*

Using this method a fuse rating lower than  $1.3 I_n$  can thus be determined.

In this case, a fuse rating higher than or equal to  $1.3 I_n$  must be chosen.

#### ***Protection against phase cutting, inversion of two phases and phase unbalance***

This is provided by a negative-phase sequence component protection (see section 7.8). The consequences of phase unbalances on motors is explained in this section. Protection against phase inversion of two phases may be carried out with a positive sequence undervoltage and phase rotation direction protection (see section 7.14).

#### ***Protection against stator frame faults***

This type of protection must be chosen in relation to the earthing system of the network feeding the motor.

##### *Motor fed by a network with direct or limiting impedance earthing*

Protection is established by an earth fault protection (see section 7.2).

The current threshold may be set at 10% of the maximum earth fault current (i.e. 10% of the limiting current for a limiting impedance earthing system). This threshold ensures protection of 90% of the windings of a star-connected motor and 100% of the windings of a delta-connected motor (see section 10.1.1).

The time delay may be fixed at 0.1 or 0.2 seconds.

It is preferable to perform the measurement by torroid.

If the measurement is performed by 3 current transformers, a stabilizing resistor must be installed. This allows spurious tripping due to saturation of the CTs during motor start-up to be avoided.

The method for determining the value of the stabilizing resistor is the same as for high impedance differential protection (see section 7.6.1.2.1).

*Motor fed by a network with unearthed neutral*

The fault current is made up of the network's capacitive currents  $I_C$  only (see section 4.3.1).

If  $I_C$  is low, i.e. less than or equal to the minimum threshold setting (1A for measurement by torroid: see section 10.1.2), earth fault protection cannot be used. The protection common to the entire network, a permanent insulation monitor (see sections 2.4.1 and 2.5.1) or a residual overvoltage protection is therefore used (see section 7.16).

If  $I_C$  is high, i.e. much higher than the minimum threshold setting, earth fault protection can be used and set at the minimum threshold.

If the cable between the protection and the motor is long, directional earth fault protection must be used so that spurious tripping upon occurrence of a fault on another outgoing feeder is avoided (see section 7.4.3 under the heading "Distinguishing between a fault current and a capacitive current").

***Protection against excessive start-up time and rotor locking***

The starting current cannot be withstood for a period lasting longer than the normal start-up time. The allowable starting current time is between 5 and 20 seconds, depending on the size of the motor and number of poles. Rotor locking causes a current which is very close to the direct starting current (6 to 8 times the nominal current). Operation of excessive start-up time and locked rotor protection is explained in section 7.9.

***Protection against a drop in supply voltage***

This is ensured by using undervoltage protection (see section 7.12) (the consequences of a drop in supply voltage on a motor are explained there).

***Protection preventing the switching device from closing while the motors still hold a remanent voltage***

This is ensured by remanent undervoltage protection (see section 7.13, which discusses the consequences of remanent voltages when the motors are re-energized).

***Protection against too many successive start-ups***

The way this type of protection operates is explained in section 7.10 (the consequences of too many successive start-ups are explained there).

***Protection against a drop in current***

This protection is used to detect pump unpriming and breaks in load coupling. It is ensured by phase undercurrent protection (see section 7.11).

***Protection against loss of excitation***

This type of protection is used for synchronous motors. It is ensured by protection against reversals in reactive power (see section 7.18, which discusses the consequences of a loss of excitation of synchronous motors).

***Protection against generator operation***

This is ensured by protection against reversals in active power (see section 7.19, which discusses the consequences of synchronous motors operating as generators).

***Protection against rotor frame faults***

For synchronous motors: protection should be chosen in relation to the supply arrangement and DC generation method. If the entire DC excitation circuit is frame insulated, an insulation fault will not affect motor operation.

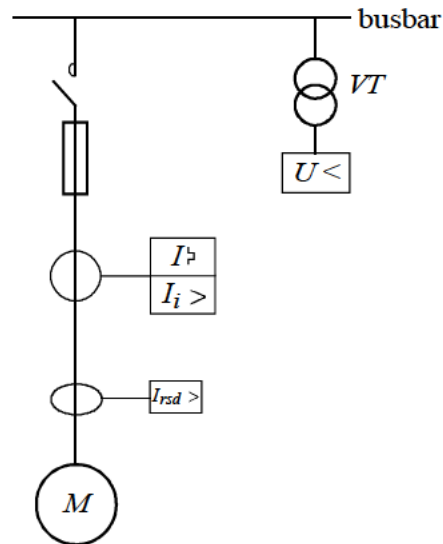
On the other hand, if a second fault occurs, this may cause an overload or short-circuit and damage the motor.

Protection against this type of fault is usually ensured by a low frequency (2.5 to 20 Hz) AC injection device. The rotor is put off voltage and the motor out of service as soon as the device detects an insulation fault. This is in order to avoid a double earth fault that may lead to the deterioration of the rotor.

For asynchronous slipping rotor motors: if the rotor is unearthed, the protection is ensured by insulation monitoring (see section 2.5.1). The motor is put out of service as soon as the device detects an insulation fault. This is in order to avoid a double earth fault that may lead to the deterioration of the rotor.

10.4.1.1. Examples of motor protection

**Contactor-controlled asynchronous motor (see Figure 10-34)**

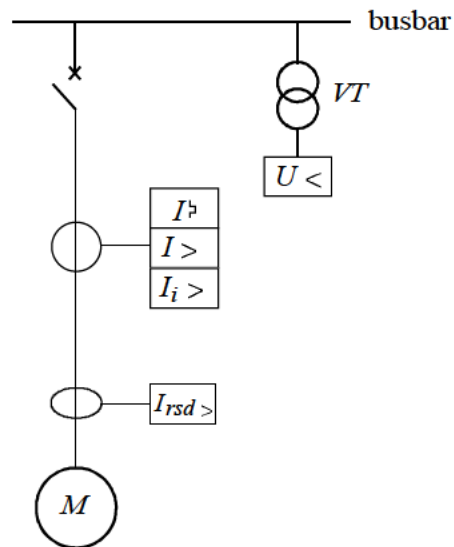


**Figure 10-34:** protection of a contactor-controlled asynchronous motor

Additional protection according to the type of load:

- excessive starting time + rotor locking;
- too many successive start-ups;
- phase undercurrent.

*Circuit-breaker-controlled asynchronous motor (see Figure 10-35)*



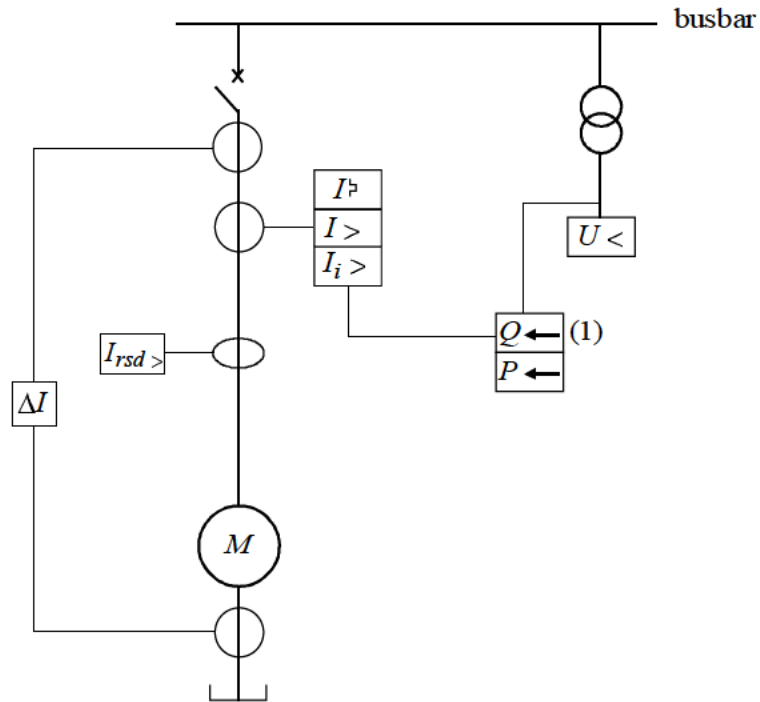
**Figure 10-35:** protection of a circuit-breaker-controlled asynchronous motor

Additional protection according to the type of load:

- excessive starting time + rotor locking;
- too many successive start-ups;
- phase undercurrent.



**High power synchronous or asynchronous motor (see Figure 10-36)**



(1) protection against reversals in reactive power in order to detect a loss of excitation (for synchronous motors only)

**Figure 10-36: protection of a high power synchronous or asynchronous motor**

Additional protection according to type of load:

- excessive starting time + rotor locking;
- too many successive start-ups;
- phase undercurrent.

10.4.1.2. *Motor protection setting indications*

See Table 10-7.

Type of fault	Settings
<b>Overload</b>	<ul style="list-style-type: none"> <li>– <b>Thermal overload protection</b> Time constant for <math>\leq 1</math> MW motor: <math>\tau = 10</math> min Time constant for <math>&gt; 1</math> MW motor: <math>\tau = 20</math> min Maximum allowable heat rise: <math>H_{set} = 115\%</math></li> <li>– <b>Temperature monitoring</b> <math>T_{set}</math> depends on the thermal class of the motor</li> </ul>
<b>Internal or external phase short-circuit</b>	<ul style="list-style-type: none"> <li>– <b>Independent time phase overcurrent protection</b> <math>I_{set} = 1.3 I_{st}</math>, time delay = 0.1 second</li> <li>– <b>Fuse protection</b> See section 10.4.1.1 for the method of determining the fuse rating</li> <li>– <b>High impedance differential protection</b> <math>I_{set} = 5</math> to 15% of <math>I_n</math></li> <li>– <b>Biased differential protection</b> <math>I_{set} = 5</math> to 15% of <math>I_n</math></li> </ul>
<b>Phase cutting, inversion of two phases and phase unbalance</b>	<ul style="list-style-type: none"> <li>– <b>Negative phase unbalance protection</b> Double threshold independent time: 1<sup>st</sup> threshold: <math>I_i = 0.2 I_n</math>, time delay = <math>T_{st}</math> + several seconds 2<sup>nd</sup> threshold: <math>I_i = 0.4 I_n</math>, time delay = 0.5 seconds  Dependent time: Protection operating curve above the point of co-ordinates <math>I_i = 0.3 I_n</math> and <math>T = T_{st}</math></li> </ul>
<b>Stator frame</b>	<ul style="list-style-type: none"> <li>– Direct or limiting impedance earthing system: <b>earth fault protection</b> <math>I_{set} = 10\% I_\ell</math> (<math>I_\ell</math>: limited earth fault current) Time delay = 0.1 to 0.2 seconds</li> <li>– Unearthed neutral system If <math>I_C</math> is low, <b>residual overvoltage protection</b> The setting depends on the network (generally <math>V_{set} = 0.3 V_n</math>)  If <math>I_C</math> is high, <b>earth fault or directional earth fault protection</b> Threshold set at the minimum (see section 10.1.2). The setting depends on the value of the network's capacitive currents</li> </ul>

Type of fault	Settings
<b>Excessive starting time or rotor locking</b>	<p>– <b>Excessive starting time</b></p> $I_{set} = \frac{I_{st}}{2} \text{ (must be } > 1.3 I_n \text{ )}$ $T = T_{st} + \text{several seconds}$ <p>– <b>Rotor locking</b></p> $I_{set} = \frac{I_{st}}{2}$ $T_b = 0.5 \text{ to } 1 \text{ second}$
<b>Drop in supply voltage</b>	<p>– <b>Undervoltage protection</b></p> $U_{set} = 0.75 \text{ to } 0.8 U_n, \text{ time delay} = 1 \text{ second}$
<b>Remanent voltage</b>	<p>– <b>Remanent undervoltage protection</b></p> $U_{set} = 20 \text{ to } 25\% \text{ of } U_n$ $T = 0.1 \text{ second}$
<b>Too many successive start-ups</b>	<p>– <b>Protection against too many successive start-ups</b></p> <p>Limited number of successive hot and cold starts</p> <p>Limited number of start-ups per hour</p> <p>The settings differ according to the manufacturer, the starting system and the short-circuit power at the connection point</p>
<b>Drop in current</b>	<p>– <b>Phase undercurrent protection</b></p> $T = 1 \text{ second}$ <p>Off-load current <math>&lt; I_{set} &lt;</math> normal minimum current</p>
<b>Loss of excitation</b>	<p>– <b>Protection against reversals in reactive power</b></p> $ Q_{set}  = 0.3 S_n, \text{ time delay} = \text{several seconds}$
<b>Generator operation</b>	<p>– <b>Protection against reversals in active power</b></p> $P_{set} = 5\% P_n, \text{ time delay} = 1 \text{ second}$
<b>Rotor frame</b>	<p>Synchronous motors:</p> <p>– <b>Injection of low frequency (2.5 Hz to 20 Hz) alternating current to monitor insulation</b></p> <p>Asynchronous slipring rotor motors:</p> <p>– <b>Insulation monitoring with Injection injection of direct current</b></p>

Table 10-7: motor protection setting indications

**10.4.2. Protection of low voltage asynchronous motors**

There are no synchronous motors in low voltage.

**Protection against overloads and phase short-circuits**

Both types of protection are ensured by the association of devices in Table 10-8.

Disconnecter-fuse/ contactor/thermal relay	Circuit-breaker/ contactor/thermal relay	Motor circuit- breakers/contactor	ACPA <sup>(1)</sup> contactor-circuit- breaker
<ul style="list-style-type: none"> <li>- very wide power range</li> <li>- used to perform all kinds of start-ups</li> <li>- proven solution</li> <li>- high breaking capacity</li> </ul>	<ul style="list-style-type: none"> <li>- wide range</li> <li>- no need for supply of fuse-cartridges</li> <li>- disconnecter visible in certain cases</li> <li>- identification of tripping due to short-circuits or overloads</li> </ul>	<ul style="list-style-type: none"> <li>- simple and compact solution for small powers</li> </ul>	<ul style="list-style-type: none"> <li>- not costly to implement</li> <li>- no maintenance</li> <li>- high safety level</li> <li>- high breaking capacity</li> <li>- long electrical life</li> </ul>
<div style="display: flex; align-items: center;"> <div style="margin-right: 10px;"> </div> <div>thermal relay for protection against overloads</div> </div> <div style="margin-top: 5px;"> <div style="display: flex; align-items: center;"> <div style="margin-right: 10px;"> </div> <div>magnetic relay for protection against phase short-circuits</div> </div> </div>			
<p>(1) ACPA self-coordinated connection, monitoring and protection devices</p>			

**Table 10-8: protection equipment against overloads and phase short-circuits for low voltage asynchronous motors**

The selection of fuses, circuit-breakers, contactors and thermal relays is defined in the catalogues in relation to the type of motor.

For example:

- gM fuses (motor-associated);
- MA type magnetic trip relay with circuit-breaker.

#### ***Other types of protection***

Large low voltage motors can be protected in a similar way to medium voltage motors using the following types of protection:

- temperature monitoring (see section 7.23);
- thermal overload (see section 7.7);
- excessive starting time and rotor locking (see section 7.9);
- phase cutting, inversion of two phases and phase unbalance (see section 7.8);
- permanent insulation monitor (see section 2.4.1) or residual current device (for frame-phase faults).

### **10.5. AC generator protection**

AC generator operation can be altered by faults occurring both within the machine and disturbances in the network to which it is connected.

An AC generator protection system therefore has a dual purpose: protecting the machine and protecting the network.

The main faults which may affect a generator are:

- overload;
- external phase-to-phase short-circuit;
- internal phase-to-phase short-circuit;
- internal phase-to-frame fault;
- rotor frame fault;
- phase cutting, inversion of two phases and phase unbalance;
- loss in excitation;
- motor operation;
- under or overfrequency;
- voltage too high or too low;
- loss of utility power supply when generator is connected to it.

***Protection against overloads***

Overcurrents point to the occurrence of overloads which, if they are prolonged, cause excessive heating, leading to accelerated ageing of the generator.

Protection is ensured:

- either by thermal overload protection (see section 7.7);
- or by temperature monitoring (see section 7.23).

***Protection against external phase-to-phase short-circuits***

External phase short-circuits are faults appearing on the network fed by the generator. This type of protection depends on whether or not there is a system allowing the short-circuit current to be maintained at roughly  $3 I_n$  for several seconds (see section 4.1.2).

*Generator fitted with a system maintaining the short-circuit current at roughly  $3 I_n$  for several seconds*

Protection is ensured by independent time phase overcurrent protection (see section 7.1).

The current threshold must be coherent with downstream protection devices. However, it may be set up to  $2.5 I_n$ .

The time delay: as short as possible allowing selectivity with the downstream protection devices.

*Generator not fitted with a system maintaining the short-circuit current at roughly  $3 I_n$*

Protection is ensured by voltage-restrained overcurrent protection (see section 7.24).

The current threshold may be set at  $1.2 I_n$ .

The time delay: as short as possible allowing selectivity with the downstream protection.

Note: installing a logic selectivity system (see section 9.3) may allow for a short time delay. The current detected by the protection is thus high (generator transient period: see section 4.1.2), and it is possible to install conventional phase overcurrent protection.

*Specific case of small generators protected by circuit-breakers with a thermal-magnetic tripping relay*

Let us consider the case of a generator directly feeding a low voltage switchboard.

– *Thermal threshold setting*: this must be set at a higher value than the nominal current, e.g. at  $1.2 I_n$ .

– *Selection and setting of magnetic tripping relay*: the magnetic relay tripping time is approximately between 10 and 20 ms. The minimum short-circuit current value on tripping is the phase-to-phase short-circuit current clear of earth for the transient period.

In section 4.2.3 we saw that the phase-to-phase short-circuit current clear of earth is equal to:

$$I_{sc2} = \frac{\sqrt{3}V_n}{Z_{(1)} + Z_{(2)}}.$$

The resistances of the generator are negligible in relation to the reactances.

Thus:

$$I_{sc2} = \frac{\sqrt{3}V_n}{X'_d + X_{(2)}} \quad \text{for the transient period.}$$

Now, the value of  $X_{(2)}$  is close to  $X''_d$  and is thus lower than  $X'_d$  (see Tables 4-7, 4-8 and 4-9). As a first approximation, we can thus take as the minimum value of the phase-to-phase short-circuit current:

$$I_{sc2,\min} = \frac{\sqrt{3}V_n}{2X'_d}$$

The setting threshold of the magnetic relay must be lower than  $0.8 I_{sc2,\min}$

$$I_m < 0.8 I_{sc2,\min}$$

***Protection against internal phase-to-phase short-circuits***

Internal phase-to-phase short-circuits may occur between turns of the same windings or of different windings following deterioration of the insulators. They generate high phase-to-phase overcurrents.

Protection may be ensured:

- using high impedance differential protection (see section 7.6.1.2.2);
- using biased differential protection.

***Protection against phase cutting, inversion of two phases and phase unbalance***

This is ensured using negative phase sequence component protection (see section 7.8). Protection against phase inversion of two phases may be carried out with a positive sequence undervoltage and phase rotation direction protection (see section 7.14).

***Protection against internal phase-to-frame faults***

This type of protection depends on the earthing system and the point where the earthing connection is installed for direct or limiting impedance earthing systems. Furthermore, the generator operates disconnected from the network during starting and stopping or during tests. The earthing system may thus be different according to whether the generator is connected or not to the network; the protection devices must therefore be suitable for both cases.

Note: the direct earthing system, whether earthing is on the generator or on the network, is not advisable because in the event of an internal phase-to-frame fault the short-circuit current would be very high and would greatly damage the generator. The result is that if a generator directly feeds (without an isolating transformer) the low voltage network:

- it is not advisable to install a TN earthing system;
- for a TT earthing system, it is necessary to check that the earthing resistance limits are enough for the fault current;
- the IT earthing system does not raise any particular difficulty for internal frame faults because the fault current is very low.

***Earthing at the neutral point of the generator stator***

Protection is:

- either of the high impedance differential type as for transformers (see section 7.6.1.2.4);
- or the overcurrent protection type located on the neutral point earthing connection.

***Earthing in the network and not at the neutral point of the generator***

It is assumed that the neutral point of the generator is unearthed. Protection may be ensured either by:

- earth fault protection located between the generator and the busbar. This causes tripping of the generator circuit-breaker when the generator is connected to the network. The current threshold may be set at 10% of the maximum earth fault current (i.e. 10% of the limiting current for a limiting impedance earthing system). This threshold allows 90% of the windings of a star-connected generator to be protected and 100% of the windings of a delta-connected generator to be protected (see section 10.1.1). The time delay may be set at 0.1 second; or by



– a permanent insulation monitor (see sections 2.4.1 and 2.5.1), or by a residual overvoltage protection (see section 7.16) when the generator is disconnected from the network and thus has an unearthed neutral system.

*Network with unearthed neutral system*

Protection is ensured by a permanent insulation monitor (see sections 2.4.1 and 2.5.1) or by a residual overvoltage protection (see section 7.16).

Note: if there is an insulation monitoring device on the network, it monitors the generator when it is connected to the network. On the other hand, it is necessary to install a monitoring device on the generator to protect it when it operates disconnected from the network.

***Protection against rotor frame faults***

Protection should be chosen in relation to the supply arrangement and DC generation method. If the entire DC excitation circuit is frame insulated, an insulation fault will not affect motor operation.

On the other hand, if a second fault occurs, this may cause an overload or short-circuit and damage the motor.

Protection against this type of fault is usually ensured by a low frequency (2.5 to 20 Hz) AC injection device. The rotor is put off voltage and the motor out of service as soon as the device detects an insulation fault. This is in order to avoid a double earth fault that may lead to deterioration of the rotor.

***Protection against a loss in excitation***

This is provided by a device protecting against reversals in reactive power (see section 7.18) (the causes and consequences of a loss of excitation are explained there).

This type of protection does not work when the generator is cut off from the network.

***Protection against motor operation***

This is ensured by a protection against reversals in active power (see section 7.19) (the causes and consequences of motor operation are explained there).

***Under or overfrequency protection***

This is ensured by an under or overfrequency protection (see section 7.17) (the causes and consequences of under or overfrequencies are explained there).

**Undervoltage protection**

This is ensured by an undervoltage protection (see section 7.12) (the causes and consequences of an undervoltage are explained there).

**Overvoltage protection**

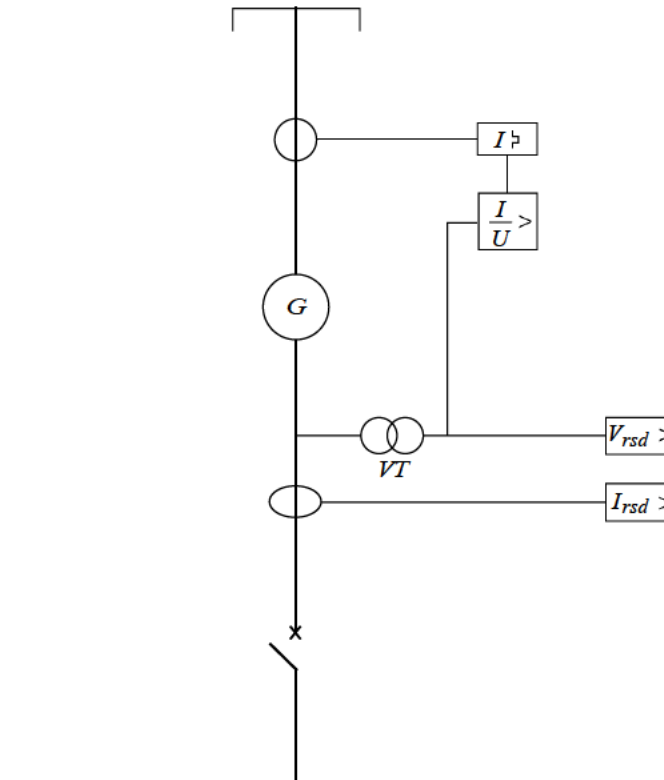
This is ensured by an overvoltage protection (see section 7.15).

**Protection against supplying active power to the utility**

This is ensured by a protection against reversals in active power (see section 7.19, which discusses the causes and consequences of supplying active power to the utility).

**10.5.1. Examples of generator protection devices**

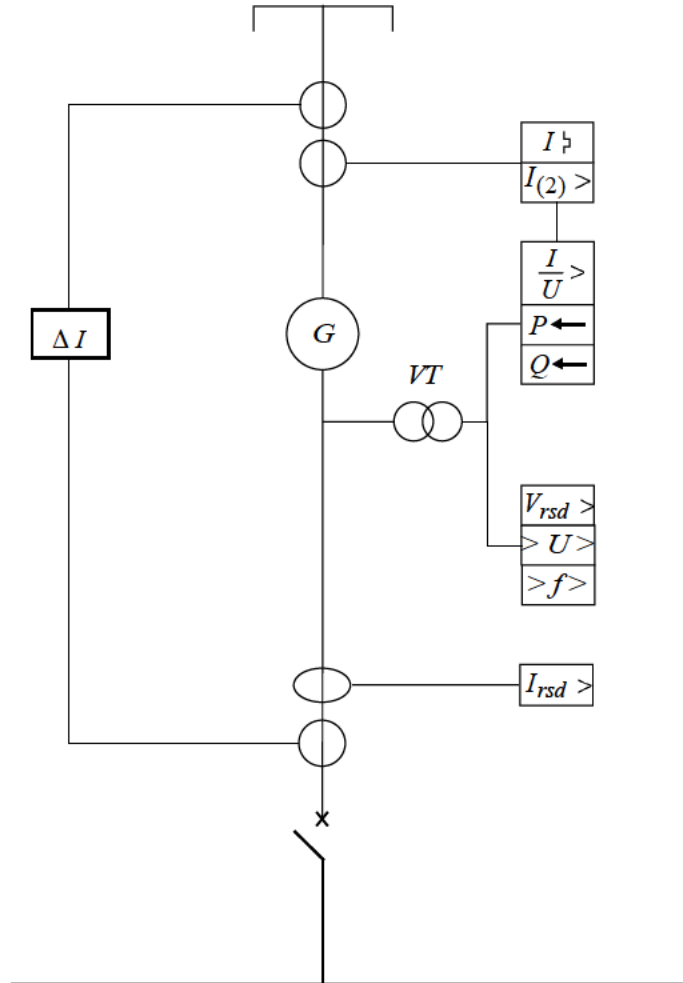
**Low power generator (see Figure 10-37)**



**Figure 10-37: low power generator protection**

It is assumed that the neutral is earthed in the network, either directly or via a limiting impedance.

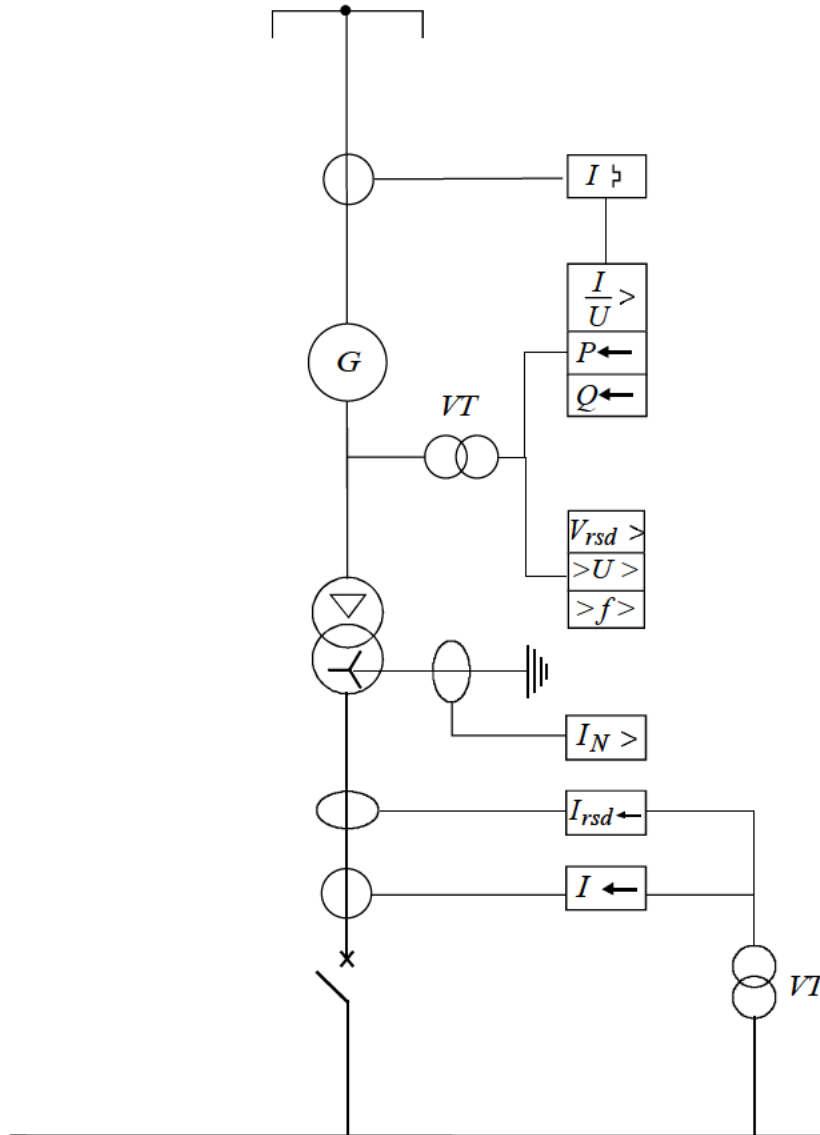
*Medium power generator (see Figure 10-38)*



**Figure 10-38:** *medium power generator protection*

It is assumed that the neutral is earthed in the network, either directly or via a limiting impedance.

*Power generator + transformer unit (see Figure 10-39)*



**Figure 10-39:** *power generator + transformer unit protection*

**10.5.2. Generator protection setting indications (Table 10-8)**

Type of fault	Settings
<b>Overload</b>	<ul style="list-style-type: none"> <li>– <b>Thermal overload protection</b> Maximum allowable heat rise <math>H_{set} = 115</math> to <math>120\%</math> Time constant: depends on generator size specifications</li> <li>– <b>Temperature monitoring</b> <math>T_{set}</math> : depends on thermal class of the generator (see generator specifications)</li> <li>– <b>Protection using a thermal-magnetic trip relay to protect small generators</b> Heat threshold = <math>1.2 I_n</math></li> </ul>
<b>External phase-to-phase short-circuits</b>	<ul style="list-style-type: none"> <li>– Generator with current held at <math>3 I_n</math> for several seconds <b>Independent time phase overcurrent protection</b> Threshold coherent with downstream protection and less than <math>2.5 I_n</math> Time delay: selectivity with downstream protection</li> <li>– Generator without current held at <math>3 I_n</math> <b>Restrained voltage overcurrent protection</b> <math>I_{set} = 1.2 I_n</math> Time delay: this depends on selectivity with downstream protection</li> <li>– <b>Protection using a thermal-magnetic trip relay to protect small generators</b> <math display="block">I_m &lt; 0.8 \frac{\sqrt{3} V_n}{2 X'_d}</math></li> </ul>
<b>Internal phase-to-phase short-circuits</b>	<ul style="list-style-type: none"> <li>– <b>High impedance differential protection</b> <math>I_{set} = 5</math> to <math>15\% I_n</math> No time delay</li> <li>– <b>Biased differential protection</b> Percentage characteristic = <math>37.5\%</math> Minimum threshold = <math>30\% I_n</math> No time delay</li> </ul>

Type of fault	Settings
Phase cutting, inversion of two phases, phase unbalance	<ul style="list-style-type: none"> <li>– <b>Inverse time negative phase sequence component protection</b>  <math>I_{set} = 15\% I_n</math>  Protection activation in several seconds at the current threshold</li> </ul>
Internal phase-to-frame short-circuits	<ul style="list-style-type: none"> <li>– Neutral earthed at the neutral point of the generator stator  <b>High impedance differential protection</b>  <math>I_{set} = 20\% I_n</math>  No time delay  <b>Overcurrent protection</b> on neutral point earthing connection  <math>I_{set} = 10\% I_\ell</math> (limiting current)  Time delay: depends on selectivity with downstream protection</li> <li>– Neutral earthed in the network  <b>Earth fault protection</b>  <math>I_{set} = 10\% I_\ell</math> (limiting current)  Time delay: 0.1 second  <b>Residual overvoltage protection or permanent insulation monitor for disconnected generator from the network</b>  <math>V_{rsd} = 30\% V_n</math>  Time delay = several seconds</li> <li>– Unearthed neutral  <b>Residual overvoltage protection</b>  <math>V_{rsd} = 30\% V_n</math>  Time delay = several seconds</li> </ul>
Rotor frame	<ul style="list-style-type: none"> <li>– <b>Injection of low frequency (2.5 Hz to 20 Hz) alternating current to monitor insulation. Permanent insulation monitor</b></li> </ul>
Loss in excitation	<ul style="list-style-type: none"> <li>– <b>Protection against reversals in reactive power</b>  <math> Q_{set}  = 0.3 S_n</math> (apparent power)  Time delay: several seconds</li> </ul>
Motor operation	<ul style="list-style-type: none"> <li>– <b>Protection against reversals in active power</b>  <math>P_{set} = 1</math> to <math>5\%</math> of <math>P_n</math> for turbine  <math>5</math> to <math>20\%</math> of <math>P_n</math> for diesel  Time delay <math>\geq 1</math> second</li> </ul>
Under or overfrequency	<ul style="list-style-type: none"> <li>– <b>Under or overfrequency protection</b>  <math>f \pm 2 \text{ Hz}</math>  Time delay: several seconds</li> </ul>

Type of fault	Settings
Undervoltage	<p>– <b>Undervoltage protection</b></p> <p><math>U_{set} = 0.75</math> to <math>0.8 U_n</math></p> <p>Time delay depending on selectivity and network requirements</p>
Overvoltage	<p>– <b>Overvoltage protection</b></p> <p>Used to protect against overvoltages: <math>U_{set} = 1.1 U_n</math> with a time delay of approximately one second</p> <p>Used to check the presence of sufficient voltage</p> <p><math>U_{set} = 0.95 U_n</math> with a time delay of approximately 3 seconds</p>
Supplying active power to the utility Loss in utility power supply	<p>– <b>Protection against reversals in active power</b></p> <p><math>P_{set} = 1</math> to <math>2\%</math> of <math>\sqrt{3} I_{nCT} U_{nVT}</math></p> <p><math>I_{nCT}</math> : current transformer rating</p> <p><math>U_{nVT}</math> : voltage transformer rating</p> <p>Zero time delay</p>

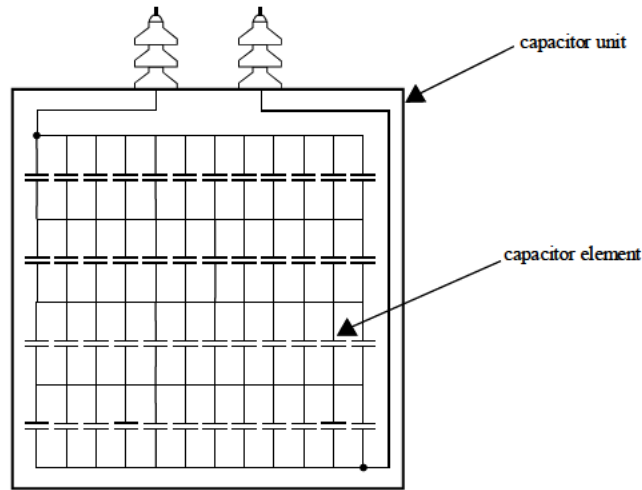
**Table 10-8:** generator protection setting indications

## 10.6. Capacitor bank protection

### Definition

*Capacitor element:* Device made of two electrodes separated by a dielectric (see Figure 10-40).

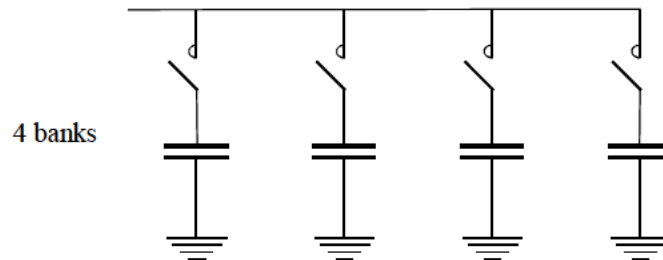
*Capacitor unit:* Set of capacitor elements placed in the same enclosure and linked to outlet terminals (see Figure 10-40).



**Figure 10-40:** diagram of an MV capacitor unit and capacitor elements

*Capacitor bank (or bank):* Set of capacitor units connected so that they can be controlled by the same switching device.

*Switched steps bank:* Combination of several so-called “switched steps” banks, each bank being separately controlled (see Figure 10-41).



**Figure 10-41:** switched steps bank

**10.6.1. Electrical phenomena related to energization**

Capacitor bank energization causes current and voltage transient operating states.

An overcurrent occurs, the amplitude and frequency of which depend on the specifications of the upstream network and the number of capacitor banks.



The upstream network is considered to be a pure inductance  $L_{up}$  such that:

$$L_{up} \omega = \frac{U_n^2}{S_{sc}} = \frac{U_n}{\sqrt{3} I_{sc}} \quad (\text{see section 4.2.1.4})$$

where:

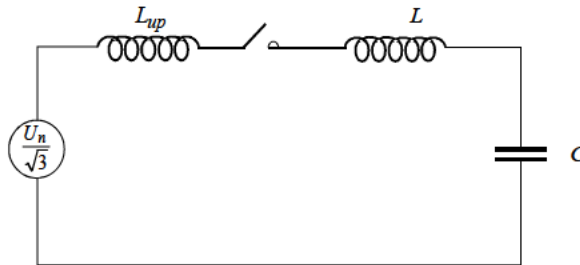
- $S_{sc}$  : short-circuit power at the capacitor connection point
- $U_n$  : nominal phase-to-phase voltage
- $I_{sc}$  : symmetrical three-phase short-circuit current at the capacitor connection point

The connection linking the switching device (contactor, circuit-breaker or switch) to the capacitor bank is considered to be a pure inductance of  $0.5 \mu H/m$ , which corresponds to an impedance of  $0.15 \Omega/km$  (see section 4.2.1.4).

Note: we can consider that resistances are negligible in relation to inductances due to the high frequency of transient currents (see examples 1 and 2).

**Fixed bank**

The equivalent single-phase diagram is shown in Figure 10-42.



$L_{up}$  : upstream network inductance

$L$  : inductance of the connection linking the switching device to the capacitor bank

**Figure 10-42:** equivalent single-phase diagram of a fixed bank

The expression of the peak inrush current is shown to be (see Appendix B):

$$\hat{I}_{rush} = \sqrt{\frac{2}{3}} U_n \sqrt{\frac{C}{L_{up} + L}}$$

where  $U_n$  : nominal phase-to-phase voltage.

$L$  represents only a few meters of cable and is then negligible in relation to  $L_{up}$ .

Hence: 
$$\hat{I}_{rush} = \sqrt{\frac{2}{3}} U_n \sqrt{\frac{C}{L_{up}}}$$

The natural frequency of this current is:

$$f_o = \frac{1}{2\pi\sqrt{L_{up}C}}$$

Its duration is equivalent to the duration of the short-circuit transient period, i.e. several tens of ms (see section 4.1.1).

Let us compare this current with the nominal current of the bank  $I_{ncapa} = C \omega \frac{U_n}{\sqrt{3}}$ :

$$\frac{\hat{I}_{rush}}{I_{ncapa}} = \sqrt{2} \times \frac{1}{\omega \sqrt{L_{up}C}}$$

By taking

$$L_{up} \omega = \frac{U_n^2}{S_{sc}}$$

and

$$Q = C \omega U_n^2$$

we obtain:

$$\frac{\hat{I}_{rush}}{I_{ncapa}} = \sqrt{2} \sqrt{\frac{S_{sc}}{Q}}$$

and

$$f_0 = f \sqrt{\frac{S_{sc}}{Q}}$$

where  $f$  is the network frequency: 50 or 60 Hz.

**Example 1**

If we take the example of a fixed 250 kVAR bank with a phase-to-phase voltage of  $U_n = 5.5$  kV fed by a network with a maximum short-circuit power of  $S_{sc} = 250$  MVA .

We have:

$$Q = C \omega U_n^2$$

hence:

$$C = \frac{250 \times 10^3}{(5.5 \times 10^3)^2 \times 314} = 26.3 \mu F$$

$$L_{up} \omega = \frac{U_n^2}{S_{sc}} \quad (\text{see section 4.2.1.4})$$

hence:

$$L_{up} = \frac{(5.5 \times 10^3)^2}{314 \times 250 \times 10^6} = 385 \mu H$$

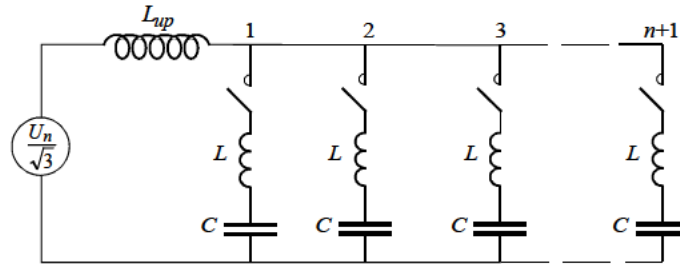
$$\frac{\hat{I}_{rush}}{I_{ncapa}} = \sqrt{2} \frac{1}{314 \times 10^{-6} \sqrt{26.3 \times 385}} = 45$$

$$f_o = \frac{1}{2 \pi \sqrt{L_{up} C}} = \frac{1}{2 \pi \sqrt{26.3 \times 385} \times 10^{-6}} = 1,582 \text{ Hz}$$

The maximum inrush peak current is equal to 45 times the bank nominal current in this example and its natural frequency is 1,582 Hz.

**Switched steps bank**

The equivalent single-phase diagram for  $(n + 1)$  banks is shown in Figure 10-43a.



$L_{up}$  : upstream network inductance  
 $L$  : inductance of the connection linking the switching device to the capacitor bank (0.5  $\mu\text{H/m}$ )

**Figure 10-43a:** equivalent single-phase diagram of a switched steps bank

The peak inrush current  $\hat{I}_{rush}$  is maximum when  $n$  banks are in service and the  $(n + 1)$  one is energized. The banks in service off load into the energized bank and, with the inductances being very low, this inrush current is very large (it is independent of the network inductance  $L_{up}$ ).

It is shown that the expression of the peak inrush current is (see Appendix B):

$$\hat{I}_{rush} = \sqrt{\frac{2}{3}} \frac{n}{n + 1} U_n \sqrt{\frac{C}{L}}$$

where  $U_n$  : nominal phase-to-phase voltage.

The natural frequency of this current is:

$$f_o = \frac{1}{2 \pi \sqrt{LC}}$$

Its duration is very short, about 1 ms.

Let us compare this current with the nominal current of a bank  $I_{ncapa}$ :

$$I_{ncapa} = C \omega \frac{U_n}{\sqrt{3}}$$

Hence:

$$\frac{\hat{I}_{rush}}{I_{ncapa}} = \sqrt{2} \frac{n}{(n+1)} \frac{f_o}{f}$$

where  $f$  is the network frequency: 50 or 60 Hz.

**Example 2**

If we take a switched steps bank containing three banks each of 350 kVAR, separated from their associated switching device by 5 meters, and with a phase-to-phase voltage of 5.5 kV, we have:

$$Q = C \omega U_n^2$$

$$C = \frac{350 \times 10^3}{(5.5 \times 10^3)^2 \times 314} = 36.8 \mu F$$

$$L = 5 \times 0.5 = 2.5 \mu H$$

hence:

$$f_o = \frac{1}{2\pi \sqrt{LC}} = 16,600$$

$$\frac{\hat{I}_{rush}}{I_{ncapa}} = \sqrt{2} \times \frac{2}{3} \times \frac{16,600}{50} = 313$$

The maximum peak inrush current is equal to 313 times the nominal current of a bank in this example and has a natural frequency of 16,600 Hz.

This very high current cannot be withstood by the capacitors and switching devices and reactors must therefore be installed to limit the inrush current (see section 10.6.3).

### 10.6.2. Protection of Schneider low voltage capacitor banks

The characteristics of capacitors are specific to each manufacturer, so we will give as an example the case of Schneider capacitor protection.

#### *Thermal sizing of equipment (switching devices and cables)*

The allowable capacitor bank overload is 30% (standard range). Variations due to tolerances on capacitor values may lead to a current increase of 5% (IEC 60831-1 allows a tolerance of 15%).

The cumulated effect of both these phenomena means that the equipment must be sized for a current of  $1.3 \times 1.05 = 1.37$  times the capacitor bank nominal current.

#### *Selecting and calibrating protection devices for capacitor banks*

We saw previously that the value of the peak inrush current of a capacitor bank could be very high (especially for a switched steps bank). In practice, Schneider low voltage capacitor banks are fitted with contactors with an inrush current limiting resistor.

This resistor prevents:

- the maximum peak current allowable for the capacitor banks,  $I_{peak,max} = 100I_{ncapa}$ , from being reached;
- the maximum making capacity of the switching devices (contactor, circuit-breaker or switch) from being reached.

Low voltage capacitor protection can be provided using a fuse or a circuit-breaker.

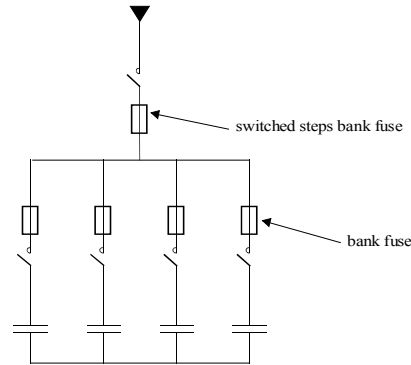
#### *Circuit-breaker protection*

As previously indicated, the rating must be above  $1.37I_{ncapa}$  and the thermal threshold may be set at  $1.37I_{ncapa}$ .

#### *Fuse protection*

*Fixed bank:* to avoid the risk of the fuses fusing after a large number of switching operations, the rating must be greater than  $1.6 I_{ncapa}$ .

Switched steps bank (see Figure 10-43b)



**Figure 10-43b:** fuse protection of a switched steps bank

The fuse rating of each bank must be above  $1.6 I_{ncapa}$  :

$I_{ncapa}$  : nominal current of a bank

The switched steps bank fuse rating must be above  $1.4 I_{n,ssb}$  :

$I_{n,ssb}$  : nominal current of the switched steps bank

It can be seen that the coefficient of increase of the switched steps bank fuse rating is 1.4 instead of 1.6 as the banks are not simultaneously energized.

Note: for capacitors fitted with anti-harmonic inductors or filters, the fuse rating is selected in relation to the nominal r.m.s. current (taking into account the harmonics). Reminder: the r.m.s. current is  $I_{r.m.s} = \sqrt{I_1^2 + \dots + I_i^2 + \dots}$ , where  $I_1$  is the value of the current at 50 Hz (or 60 Hz) and  $I_i$  is the value of the order  $i$  harmonic current. The fuse rating of each bank must be above  $1.4 I_{r.m.s, capa}$  and  $I_{r.m.s, capa}$  : nominal r.m.s. current of a bank. The switched steps bank fuse rating must be above  $1.2 I_{r.m.s, ssb}$  and  $I_{r.m.s, ssb}$  : nominal r.m.s. current of the switched steps bank. It can be seen that the fuse rating coefficients of increase are lower than when there is no anti-harmonic inductor or filter. Indeed, these inductors limit the inrush current.

### 10.6.3. Protection of Schneider Medium Voltage capacitor banks

The characteristics of capacitors are specific to each manufacturer, so we will give as an example the case of Schneider capacitor protection.

### *Composition of high voltage capacitors*

High voltage capacitors are made up of elements connected in series to obtain voltage and connected in parallel to obtain the required capacitance.

There are two types of capacitors: one having internal protection fuses and the other not.

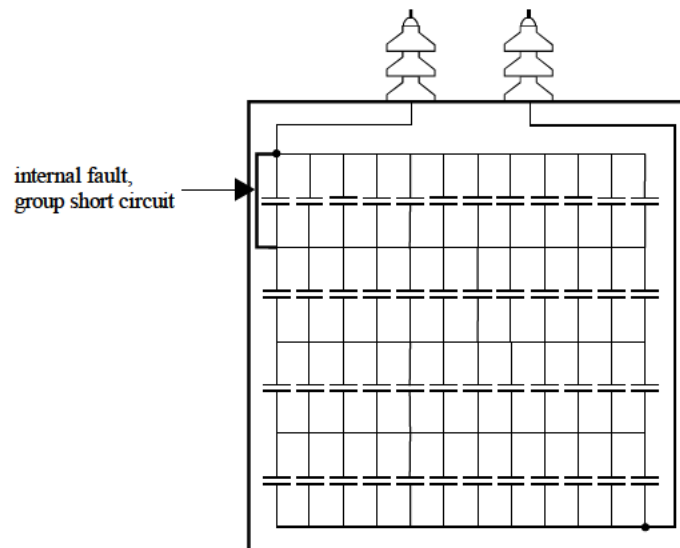
#### *Capacitors without internal protection fuses*

A capacitor fails when an internal element breaks down. A fault on an element causes the shorting of a series-connected group and thus a rise in voltage in other series-connected groups (see Figure 10-44).

Owing to the fact that there is no protective device inside the capacitor, the fault will only be cleared by the bank being disconnected due to the detection of an overcurrent.

This type of capacitor is used in a delta-connected bank protected by fuses or overcurrent protection devices as an internal fault causes a high phase-to-phase current.

This type of capacitor is also used in a double-star connected bank with neutral to neutral unbalanced protection which is activated upon occurrence of the first fault.



**Figure 10-44:** capacitor without internal protection fuses

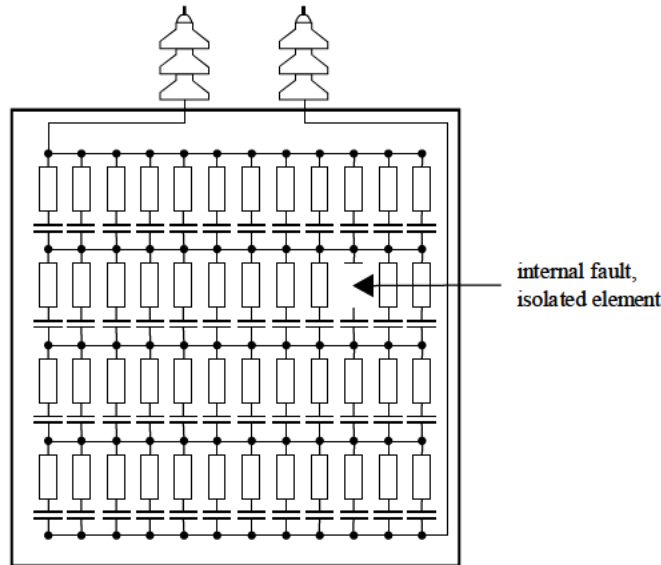


*Capacitors with internal protection fuses*

Each element is protected by a fuse. Any fault on an element will therefore be cleared and the faulty circuit isolated (see Figure 10-45). This is followed by a slight variation in the capacitance and an increase in the voltage applied to the parallel-connected elements.

This is why this type of capacitor is only used in a double star-connected bank (see Figure 10-47). The unbalance protection threshold is adjusted so that the loss of elements within the same series-connected group causes the bank to be tripped when the overvoltage on the parallel-connected elements becomes too high.

Internal fuse protection increases capacitor bank reliability since the loss of an element does not systematically lead to the bank being tripped.



**Figure 10-45:** *capacitors with internal protection fuses*

**Capacitor bank layout**

*Delta-connected bank (see Figure 10-46)*

Capacitors with internal fuses will never be used in this type of layout as their breaking capacity is not high enough for network short-circuit currents.

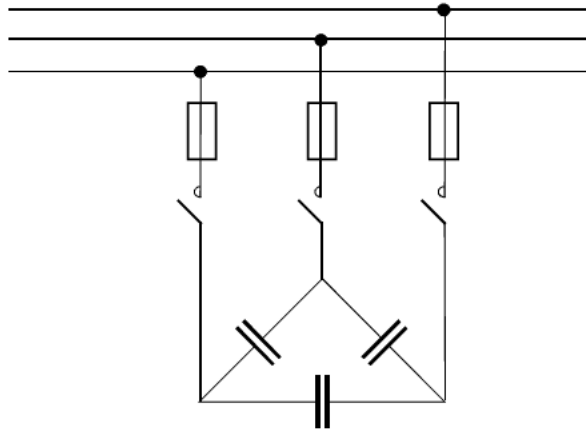


Figure 10-46: delta-connected bank

*Double star-connected bank (see Figure 10-47)*

The bank is divided into two star connections. When a capacitor is faulty an unbalance current appears in the neutral circuit. This current is detected by a suitable protection (see section 7.26).

This type of bank can be used with capacitors with or without internal fuses.

It can be designed for any type of network up to EHV networks. The assembly principle is always the same: to reach voltage levels of 100 kV and 200 kV a sufficient number of MV capacitors is connected in series.

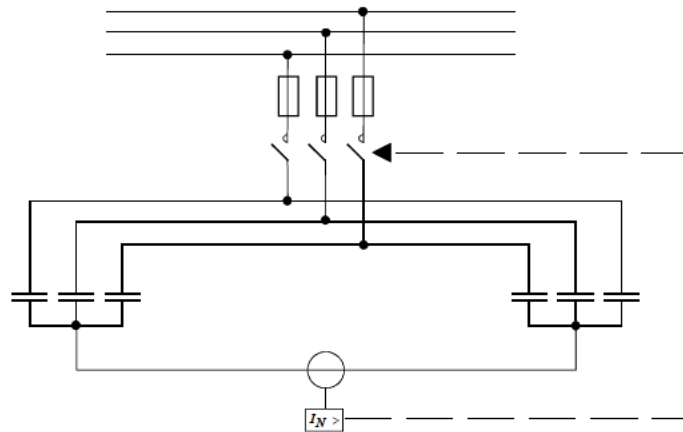


Figure 10-47: double star-connected bank

***Thermal sizing of equipment (switching devices and cables)***

Taking into account the allowable overloads and tolerances on capacitor values, the equipment must be rated for a current 1.43 times the nominal current of the capacitor bank.

***Limiting the inrush current by installing an impulse reactor***

High voltage capacitors do not have a contactor with a limiting resistor (unlike in low voltage).

In order to ensure durability of equipment, the inrush current must be lower than:

- the maximum peak current that can be withstood by the bank  $I_{capa,max}$  ;
- the making maximum peak current of the device's performing capacitor energizing (contactor, switch or circuit-breaker) for a maximum number of switching operations  $I_{make,Nmax}$  (see Table 10-9).

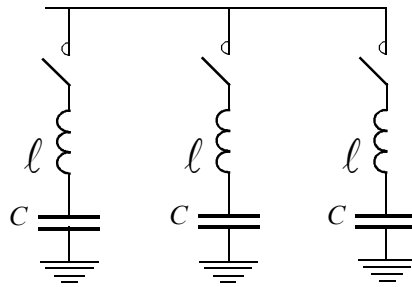
The maximum peak current that can be withstood by the Schneider bank is equal to 100 times its nominal current. The inrush current must therefore be lower than  $100 I_{ncapa}$ .

Table 10-9 gives the making maximum peak current and the maximum number of switching operations of the Schneider devices.

Device	Designation	Use with maximal number of makings		Use with the maximal making current	
		Max. no. of switching operations (N max.)	I make corresponding to N max. (kA)	No. of switching operations at I make max.	I make max.; (kA)
<i>Circuit-breaker</i>	SF1	10,000	10	3,500	15
	SF2	10,000	13	2,000	25
	LF1	10,000	13	2,000	25
	LF2	10,000	13	2,000	25
	LF3	10,000	13	2,000	25
<i>Contactor</i>	Rollarc	80,000	2	15,000	4
<i>Switch</i>	ISF1	10,000	10	3,500	15

**Table 10-9:** characteristics of Schneider devices

When one of these conditions is not fulfilled, an impulse reactor  $\ell$  is inserted between the capacitor and the switching device (see Figure 10-48). The inductance of the connection linking the switching device to the capacitor bank ( $0.5 \mu\text{H/m}$ ) is negligible in relation to the value of the impulse reactor (approximately  $100 \mu\text{H}$ : see example below).



**Figure 10-48:** insertion of impulse reactor to limit the inrush current

This reactor is used to limit the inrush current to a value less than the current that the capacitor and switching device can withstand.

The condition is:  $\hat{I}_{rush} \leq \min(100 I_{capa,max}, I_{make,Nmax})$ .

*Single capacitor*

Generally, it is not necessary to insert an impulse reactor as the inrush current is not very high (see example 1, section 10.6.1), except where the network short-circuit power  $S_{sc}$  is high and the compensation power  $Q$  is low.

Using the expression  $\frac{\hat{I}_{rush}}{I_{ncapa}}$  in section 10.6.1, the impulse reactor is chosen as

necessary:

Let  $I_{peak,max}$  be the smallest value between  $I_{capa,max}$  and  $I_{make,Nmax}$ .

$$I_{peak,max} = \min(I_{capa,max}, I_{make,Nmax})$$

$$\text{Then: } \ell \geq \frac{10^6}{\omega} \left( \frac{2Q}{3(I_{peak,max})^2} - \frac{U_n^2}{S_{sc}} \right) \text{ must be taken}$$

$\ell$  :  $\mu\text{H}$

$U_n$  : phase-to-phase voltage in kV

$$\begin{aligned} Q &: \text{MVAR} \\ \hat{S}_{sc} &: \text{MVA} \\ I_{peak,max} &: \text{kA peak} \end{aligned}$$

*Switched steps bank with n + 1 banks*

The maximum peak inrush current is generally very high (see example 2, section 10.6.1), and it is thus necessary to insert an impulse reactor.

Using the expression  $\frac{\hat{I}_{rush}}{I_{ncapa}}$  in section 10.6.1, the impulse reactor is chosen when necessary:

Let  $I_{peak,max}$  be the smallest value between  $I_{capa,max}$  and  $I_{make,Nmax}$ :

$$I_{peak,max} = \min ( I_{capa,max} , I_{make,Nmax} )$$

Then: 
$$\ell \geq \left( \frac{n}{n+1} \right)^2 \frac{2 \times 10^6}{3 \omega} \frac{Q}{(I_{peak,max})^2} \quad \text{must be taken}$$

$$\begin{aligned} \ell &: \mu\text{H} \\ Q &: \text{reactive power of a bank in MVAR} \\ I_{peak,max} &: \text{kA peak} \end{aligned}$$

The conditions on reactor sizing are:

- nominal permanent current:  $1.43 I_{ncapa}$  ;
- thermal withstand to transient overcurrents: 30 to 50  $I_{ncapa}$  for 1 second;
- electrodynamic withstand: peak value of the short-circuit current which is lower than or equal to  $\min ( I_{capa,max} , I_{make,Nmax} )$  .

### **Example**

Let us look again at example 2: a switched steps bank with three banks each of 350 kVAR, located 5 meters away from their associated switching device, and with a phase-to-phase voltage of 5.5 kV.

Let us assume that:

$$I_{capa,max} = 100 I_{ncapa}$$

$$I_{make,Nmax} = 10 \hat{kA}$$

$$Q = \sqrt{3} U_n I_{ncapa}$$

hence:

$$I_{ncapa} = \frac{350 \times 10^3}{\sqrt{3} \times 5.5 \times 10^3} = 36.7 A$$

We previously saw that  $\frac{\hat{I}_{rush}}{I_{ncapa}} = 313$

hence:

$$\hat{I}_{rush} = 11,487 A$$

Neither the bank nor the contactor can therefore withstand the peak current.

Determining the impulse reactor:

$$100 I_{ncapa} = 3,670 A. \text{ This is then the most restrictive.}$$

It is necessary to take:

$$\ell \geq \left(\frac{2}{3}\right)^2 \frac{2 \times 10^6}{3 \times 314} \frac{0.35}{(3.67)^2}$$

$$\ell \geq 24.5 \mu H$$

A reactor of 50  $\mu H$  can be taken.

The conditions on reactor sizing are:

– nominal permanent current:  $1.43 I_{ncapa} = 52.5 A$ ;

– thermal withstand to transient overcurrents:

$$30 \text{ to } 50 I_{ncapa} = 1,101 \text{ to } 1,835 A \text{ for 1 second;}$$

– electrodynamic withstand: peak value of the short-circuit current which is lower than or equal to  $\min(100 I_{ncapa}, I_{make, Nmax}) = 3,670 A$ .

### ***Selection and settings of overcurrent protection devices***

Protection against overcurrents can be provided by a fuse or a circuit-breaker fitted with a double threshold independent time protection.

#### ***Fuse protection***

The inrush current, even when limited by an impulse reactor, can lead to the fuses deteriorating. To determine the fuse rating, the peak inrush current must be calculated, as previously indicated, and the time constant of this transient current determined. The method is fairly complex and the upstream network resistance and fuse resistance must be known.

A software program exists which determines the fuse rating.

In practice, ratings of *1.8 to 2.5 times the nominal current* of the capacitor bank are used.

*Protection using a circuit-breaker fitted with a double threshold independent time protection*

– *low threshold*  $I_{lset}$

This protects against overloads. It must be set at 1.43 times the capacitor bank nominal current.

$$I_{lset} = 1.43 I_{ncapa}$$

The time delay  $T_l$  can be set at several seconds.

When the current is not sinusoidal, the overload protection must measure the actual r.m.s. value of the current:

$$I_{rms} = \sqrt{I_1^2 + \dots + I_i^2 + \dots}$$

where:

$I_1$ : current value at 50 Hz (or 60 Hz)

$I_i$ : order  $i$  harmonic current value

– *high threshold*  $I_{hset}$

This provides protection against short-circuits. It must be set at a value below the minimum short-circuit current:

$$I_{hset} \leq 0.8 I_{sc2, \min}$$

Using the calculation, it can be shown that the duration of the inrush current is short (especially for switched steps banks). It is less than 200 ms.

The time delay  $T_h$  can therefore be set at 0.2 seconds.

*Protection against internal faults for double star-connected batteries*

As shown in Figure 10-49, a relay providing protection against unbalances between neutral points (see section 7.26) can be used to detect the circulation of a current in the link between the two neutral points.

This current is caused by the deterioration of capacitor elements.

The setting threshold is given by the manufacturer.

The time delay is set at 0.1 second.

## 10.8. Protection of direct current installations

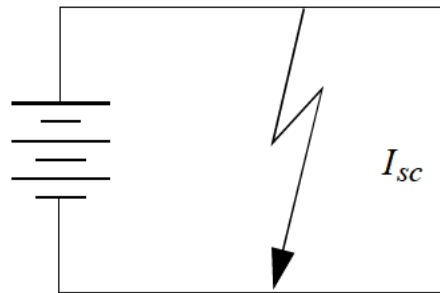
### *Differences between AC and DC installations*

Although the basic design principles in each case are the same, there are nevertheless differences in:

- the fault current calculations (short-circuit or insulation fault);
- the choice of protective devices to be installed which must be suitable for the direct current.

### 10.8.1. Short-circuit current calculation

*Storage battery (see Figure 10-49)*



**Figure 10-49:** short-circuit at the terminals of a storage battery

When a short-circuit occurs at its terminals, a storage battery will pass a current according to Ohm's law:

$$I_{sc} = \frac{V_b}{R_i}$$

$V_b$  : maximum discharge voltage (fully charged battery)

$R_i$  : internal resistance of the entire battery (value generally given by the manufacturer in relation to its ampere-hour capacity)

When the internal resistance is not known, the following approximate formula can be used:

$$I_{sc} = k C$$



where  $C$  is the capacity of the battery expressed in ampere-hours and  $k$  is a coefficient close to 10, and always less than 20.

*Example*

What is the short-circuit current at the terminals of a battery with the following characteristics:

- capacity: 500 Ah
- maximum discharge voltage: 242 V ( $110 \times 2.2$  V elements)
- discharge current: 300 A
- autonomy: 1/2 hour
- internal resistance: 0.5 m $\Omega$  per element

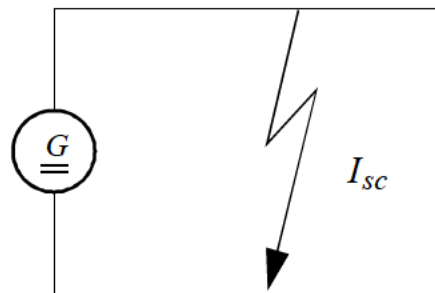
The following is calculated:

$$R_i = 110 \times 0.50 \times 10^{-3} = 55 \times 10^{-3}$$

$$I_{sc} = \frac{242}{55 \times 10^{-3}} = 4.4 \text{ kA}$$

As the calculation shows, the short-circuit currents are relatively low.

**Direct current generator (see Figure 10-50)**



**Figure 10-50:** short-circuit at the terminals of a direct current generator

If  $V_g$  designates the electro-motive force of the generator and  $R_i$  its internal resistance, then:

$$I_{sc} = \frac{V_g}{R_i}$$

In the absence of specific indications and for a network with a nominal voltage of  $U_n$ , we can take:

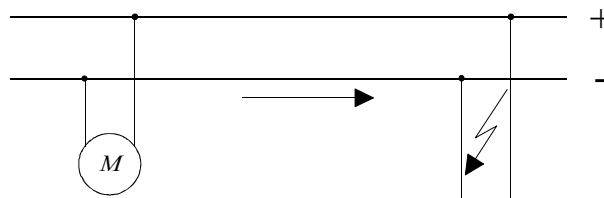
$$V_g = 1.1 U_n$$

*Example*

Short-circuit at the terminals of a 200 kW generator (see Figure 10-50) at 230 V and with an internal resistance of  $R_i = 0.032 \Omega$ .

$$I_{sc} = \frac{1.1 \times 230}{0.032} = 7.9 \text{ kA}$$

*At any point in an installation (see Figure 10-51)*



**Figure 10-51:** short-circuit at any point in an installation

$$I_{sc} = \frac{V}{R_i + 2 R_L}$$

- $R_i$  : internal resistance of the DC source
- $R_L$  : sum of link resistances per polarity between the source and short-circuit point
- $V$  :  $V_b$  or  $V_g$  as previously defined

The influence of the DC motors that feed the short-circuit can be taken into account by increasing the short-circuit current by the following value:

$$I_{sc,mot} = 6 I_{n,mot}$$

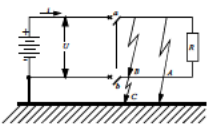
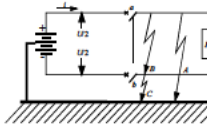
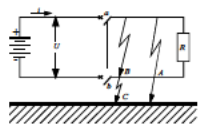
$I_{n,mot}$  : sum of nominal currents of motors likely to operate simultaneously

$$I_{sc} = \frac{V}{R_i + 2R_L} + 6I_{n,mot}$$

**10.8.2. Characteristics of insulation faults and switchgear**

Switching devices are sensitive to the DC voltage level at their terminals when they have to clear a short-circuit.

Table 10-10 can be used to determine these voltages, which depend on the source voltage and the way it is earthed.

Types of network		Earthed networks		Unearthed networks (case 3)
		Source with one polarity earthed (case 1)	Source with mid-point earthed (case 2)	
Earthing layouts and various fault conditions				
Analysis of each fault	fault A	The pole must break the maximum $I_{SC}$ under $U$	The pole must break the $I_{SC}$ close to the maximum $I_{SC}$ under $U/2$	No short-circuit in this case
	fault B	Both poles must break the maximum $I_{SC}$ under $U$	Both poles must break the maximum $I_{SC}$ under $U$	Both poles must break the maximum $I_{SC}$ under $U$
	fault C	No short-circuit current in this case	<i>Idem</i> fault A, but concerning the negative pole	No short-circuit current in this case
Most unfavorable case		Fault A	Faults A and C	Fault B (or A and C)
Case of a circuit-breaker		All the poles effectively participating in current interruption are connected in series on the positive polarity (or negative if the positive polarity is earthed). An additional pole must be provided to be inserted in the earthed polarity to permit circuit isolation	Provide the number of poles necessary to break $I_{SC, max}$ under voltage $U/2$ for each polarity	Distribute the number of poles necessary for breaking on each polarity

**Table 10-10: switchgear characteristics in relation to the type of DC network**

### 10.8.3. Protection of persons

The rules for protection are the same as those for AC networks. However, the conventional voltage limits and tripping times of protective devices are different:

- all exposed conductive parts are therefore interconnected and earthed;
- automatic tripping takes place in the time period specified.

*RCDs cannot be used.*

In practice, therefore, the following apply:

- *The principles of the TN scheme for cases 1 and 2 of Table 10-11.* It is thus sufficient to check that, in the event of an insulation fault, the short-circuit current is large enough to cause the trip relays of the circuit-breakers providing overcurrent protection to operate. The checking methods are identical to those used for an AC network.

- *The principles of the IT scheme for case 3 in Table 10-11:*

- network insulation must be monitored and the occurrence of an insulation fault reported. A permanent insulation monitor must therefore be installed (see Figure 10-52);

- the simultaneous presence of two faults on each polarity causes a short-circuit which is cleared by the overcurrent protective devices. As for an AC system, it is sufficient to make sure that the current is large enough to cause the magnetic or short-time relays to be operated.

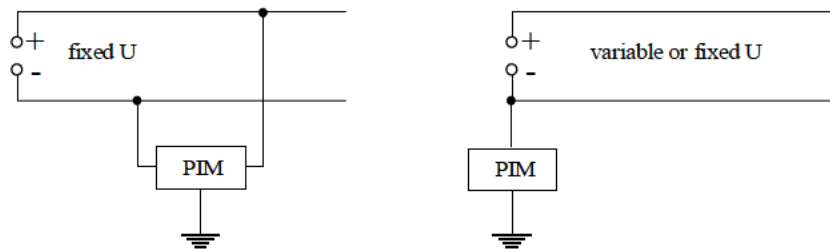


Figure 10-52: installation of permanent insulation monitors on a DC network with an IT layout

### 10.9. Protection of uninterruptible power supplies (UPS)

The layout of a UPS system with a single inverter is shown in Figure 10-53.

We shall determine the choice and settings of circuit-breakers CB1, CB2, CB3 and  $CB_{DC}$  providing selective protection against short-circuits.

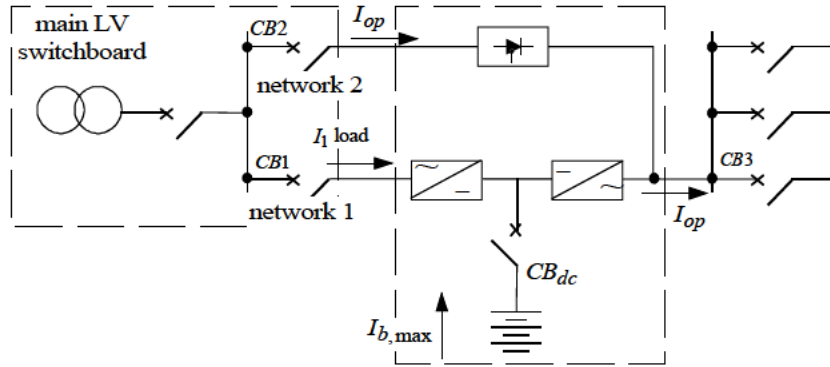


Figure 10-53: UPS with networks 1 and 2 being separated

10.9.1. Choice of circuit-breaker ratings

**CB1 rating**

This is determined by the operating current  $I_{op}$  :

$$I_{rat,CB2} \geq I_{op}.$$

**CB<sub>dc</sub> rating**

This is determined by the maximum current given by the battery  $I_{b,max}$

$$I_{rat,CBdc} \geq I_{b,max}$$

**CB1 rating**

This is determined by the maximum input current of the rectifier  $I_1$  when the battery is recharging:

$$I_{rat,CB1} \geq I_1.$$

As an example, Table 10-11 gives the values of  $I_{op}$ ,  $I_{b,max}$  and  $I_1$  for GALAXY systems of MGE UPS with an autonomy of 10 min and 15 min.

The values shown correspond to the following conditions:

- fully loaded at  $\cos \varphi = 0.8$  ;
- for a network 1 nominal voltage of 400 V.

For network 1 nominal voltages of 380 V and 415 V, the current  $I_1$  and  $I_{op}$  values must be multiplied by 1.05 and 0.96 respectively.

nominal power (in kVA)	$I_1$ (A ~)			$I_{op}$ (A ~)	$I_{b, max}$ (A ~)
	floating	recharging with 10 mn autonomy	recharging with 15 mn autonomy		
40	65	80	81	58	102
60	97	120	121	87	152
80	130	170	172	116	204
100	162	211	213	145	252
120	195	252	254	173	303
160	257	326	327	231	404
200	321	404	411	289	505
250	402	507	513	361	631
300	482	608	617	433	757

**Table 10-11:** line currents absorbed by *GALAXY* systems

### **CB3 rating**

This is determined by the nominal current of each outgoing feeder.

Section 10.9.3 shows the condition to be satisfied on the CB3 circuit-breaker rating to ensure selectivity with the CB2.

#### **10.9.2. Choice of circuit-breaker breaking capacity**

– Circuit-breakers CB1 and CB2 must have a breaking capacity greater than or equal to the maximum short-circuit current at the connection point of the UPS. This current is calculated using the usual method shown in section 4.2.1.

– Circuit-breaker  $CB_{dc}$  must have a DC breaking capacity greater than the battery short-circuit current (see section 10.8.1 for how to calculate the short-circuit current of a storage battery).

#### **10.9.3. Selectivity requirements**

In the event of a fault on an outgoing feeder, selectivity is ensured by CB3 being tripped without CB2 being tripped or the inverter being tripped by self-protection.

*Case 1: selectivity only when network 2 is in service*

Let us assume that selectivity is not required when the load is fed by the inverter alone, i.e. when network 2 is out of service.

The selectivity study is none other than a conventional study between an upstream circuit-breaker CB2 and a downstream circuit-breaker CB3.

Indeed, the static contactor controlled by the UPS automatic system allows switchover to network 2 to take place in a very short time ( $< 1 \text{ ms}$ ) upon occurrence of a short-circuit downstream of an outgoing feeder. Circuit-breakers CB2 and CB3 thus see the short-circuit on network 2.

To ensure selectivity, check that the circuit-breakers CB3 are selective with the circuit-breaker CB2 for a short-circuit fed by network 2.

When the fault is cleared by the circuit-breaker CB3, the static contactor controlled by the UPS automatic system allows switchover to network 1 with no cut in power.

Note: there may be an LV/LV transformer on the network 2 → static contactor link (see section 1.6.3), which reduces the value of outgoing feeder short-circuit currents. Network 2 may have a back-up power supply provided by a generator set (see section 1.6.3). Selectivity must therefore be provided for both power supplies, by the generator set or by the network.

*Case 2: selectivity even when network 2 is out of service*

Let us assume that the selectivity is required even when the load is fed by the inverter alone, i.e. when network 2 is out of service.

In this case, the inverter must be able to supply a short-circuit current able to trip circuit-breaker CB3 which has the highest current rating. When an overcurrent occurs, inverters operate as peak current limiters. For example, MGE UPS inverters limit the peak current at  $2.33 I_{n,inv}$  for a period of one second. Beyond one second, the inverter is put out of service by self-protection.

Thus, a short-circuit on an outgoing feeder will cause a current limited by the inverter, while the fault is being cleared by circuit-breaker CB3 (approximately 20 ms). Once the fault has been cleared, the inverter returns to normal operation.

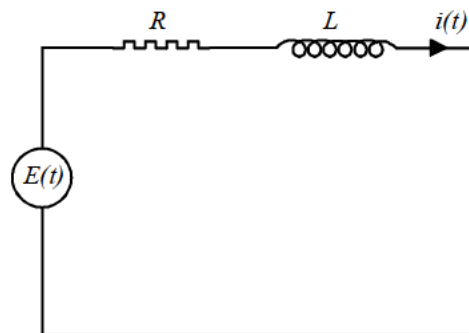
Selectivity is ensured if this current is high enough to cause circuit-breaker CB3 to be tripped. Its magnetic threshold (see section 8.1) must then be lower than the peak current limited by the inverter. Generally a low threshold must be chosen, for example, a B type according to IEC 60947-2.

Note: when the inverter operates as limiter, it supplies a square signal, limited peak current value is thus equal to limited r.m.s. current value.

## Appendix A

# Transient Current Calculation of Short-circuit Fed by Utility Network

The equivalent upstream network diagram during a solid short circuit is shown in Figure A-1.



$E(t)$  : single-phase voltage

$R, L$  : sum of resistances and reactances of the cables, lines and transformers through which the short circuit current flows (recalculated for the voltage  $E$ )

**Figure A-1:** equivalent diagram upon occurrence of a solid short circuit



It is assumed that at the moment the short circuit occurs, the voltage phase is  $\alpha$ .

The current  $i(t)$  is determined by the following differential equation:

$$E(t) = R i(t) + L \frac{di}{dt}$$

where: 
$$\begin{cases} E(t) = 0 & \text{for } t < 0 \\ E(t) = \hat{E} \sin(\omega t + \alpha) & \text{for } t \geq 0 \end{cases}$$

We shall solve this differential equation using Laplace transforms.

As a Laplace transform, the differential equation becomes:

$$E(s) = R I(s) + L [s I(s) - i(t=0)]$$

$$E(s) = R I(s) + L s I(s)$$

as it is assumed that the current is zero (negligible) before the fault, then  $i(t=0) = 0$ .

The Laplace transform tables give us:

$$\gamma(t) \sin(\omega t + \alpha) \quad \square \quad \frac{\omega \cos \alpha + s \sin \alpha}{s^2 + \omega^2}$$

hence: 
$$\hat{E} \left( \frac{\omega \cos \alpha + s \sin \alpha}{s^2 + \omega^2} \right) = I(s) [R + Ls]$$

$$I(s) = \frac{\hat{E} (\omega \cos \alpha + s \sin \alpha)}{L (s^2 + \omega^2) \left( s + \frac{R}{L} \right)}$$

To reverse the Laplace transform  $I(s)$ , it must be written differently.

We know that we can write  $I(s)$  as:

$$I(s) = \frac{As + B}{s^2 + \omega^2} + \frac{C}{\left(s + \frac{R}{L}\right)} = \frac{\hat{E} (\omega \cos \alpha + s \sin \alpha)}{L (s^2 + \omega^2) \left(s + \frac{R}{L}\right)}$$

We shall thus look for the value of coefficients  $A$ ,  $B$  and  $C$ .

### **Search for coefficient $C$**

By multiplying the two terms of the equation by  $\left(s + \frac{R}{L}\right)$ , and by taking

$s = -\frac{R}{L}$  we obtain:

$$C = \frac{\hat{E} \left( \omega \cos \alpha - \frac{R}{L} \sin \alpha \right)}{\frac{R^2}{L^2} + \omega^2}$$

$$C = \hat{E} \frac{(L\omega \cos \alpha - R \sin \alpha)}{R^2 + L^2 \omega^2}$$

Let us take:  $Z^2 = R^2 + L^2 \omega^2$

If  $\varphi$  is the network's natural phase displacement, we have:  $\cos \varphi = \frac{R}{Z}$  and

$$\sin \varphi = \frac{L\omega}{Z}$$

where:  $Z = \sqrt{R^2 + L^2 \omega^2}$

$$\begin{aligned} \text{Hence: } C &= \frac{\hat{E}}{Z} (\sin \varphi \cos \alpha - \cos \varphi \sin \alpha) = \frac{\hat{E}}{Z} \sin (\varphi - \alpha) \\ &= -\frac{\hat{E}}{Z} \sin (\alpha - \varphi) \end{aligned}$$

**Search for coefficient  $A$** 

If we make  $s$  stretch to infinity, we obtain the following equation:

$$\frac{A}{s} + \frac{C}{s} = - \underbrace{\frac{\hat{E}}{L} \frac{s}{s^3}}_{\text{term in } \frac{1}{s^2}} \sin \varphi$$

$$\text{hence: } A = -C = \frac{\hat{E}}{Z} \sin(\alpha - \varphi)$$

**Search for coefficient  $B$** 

If we make  $s$  stretch to 0, we obtain the following equation:

$$\frac{B}{\omega^2} + \frac{C}{\left(\frac{R}{L}\right)} = \frac{\hat{E}}{L} \frac{\omega \cos \alpha}{\omega^2 \frac{R}{L}}$$

$$B = \frac{\hat{E} \omega}{R} \cos \alpha - \frac{C \omega^2}{\frac{R}{L}}$$

$$B = \frac{\hat{E} \omega}{R} \cos \alpha + \frac{\hat{E}}{Z} \frac{\omega^2}{\frac{R}{L}} \sin(\alpha - \varphi)$$

$$B = \frac{\hat{E} \omega}{Z} \left[ \frac{Z}{R} \cos \alpha + \frac{L \omega}{R} \sin(\alpha - \varphi) \right]$$

$$B = \frac{\hat{E} \omega}{Z} \left[ \frac{1}{\cos \varphi} \cos \alpha + \frac{\sin \varphi}{\cos \varphi} \sin(\alpha - \varphi) \right]$$

$$B = \frac{\hat{E} \omega}{Z} \left[ \frac{\cos \alpha}{\cos \varphi} - \frac{\sin^2 \varphi \cos \alpha + \sin \varphi \cos \varphi \sin \alpha}{\cos \varphi} \right]$$

$$B = \frac{\hat{E} \omega}{Z} [\cos \alpha \cos \varphi + \sin \alpha \sin \varphi] \text{ by using } 1 - \sin^2 \varphi = \cos^2 \varphi$$

$$B = \frac{\hat{E} \omega}{Z} \cos(\alpha - \varphi)$$

We can thus write  $I(s)$  as follows:

$$I(s) = \frac{\hat{E}}{Z} \left[ \frac{s \sin(\alpha - \varphi) + \omega \cos(\alpha - \varphi)}{s^2 + \omega^2} - \frac{\sin(\alpha - \varphi)}{\left(s + \frac{R}{L}\right)} \right]$$

Using the Laplace transform tables, we can deduce  $i(t)$ :

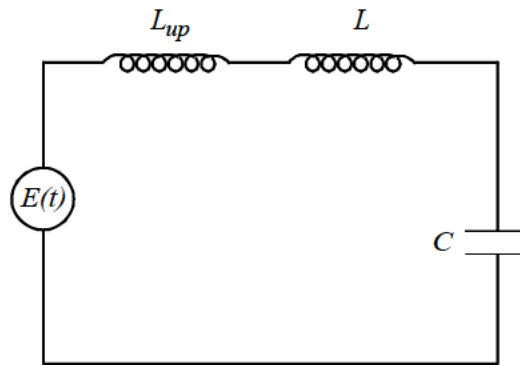
$$i(t) = \frac{\hat{E}}{Z} \left[ \sin(\omega t + \alpha - \varphi) - \sin(\alpha - \varphi) e^{-\frac{R}{L} \omega t} \right]$$

## Appendix B

### Calculation of Inrush Current During Capacitor Bank Energization

#### *Fixed bank*

The equivalent upstream network single-phase diagram during energization of the fixed bank is shown in Figure B-1.



$E(t)$  : single-phase voltage

$L_{up}$  : upstream network inductance

$L$  : inductance of the connection linking the switching device to the capacitor bank

**Figure B-1:** equivalent diagram during fixed bank energization

We shall demonstrate that the frequency of the transient current occurring upon energization is very high (see section 10.6.1, example 1;  $f_0 = 1,582$  Hz).

This results in justification of neglect of the network resistance in relation to the inductance:  $R_{up} \ll 2 \pi f_0 L_{up}$ , since  $f_0 \gg 50$  Hz.

Similarly, the resistance of the connection linking the switching device to the capacitor is negligible.

The network frequency (50 Hz) is negligible in relation to the transient current frequency. We might therefore consider that we have a voltage step throughout the duration of the transient current.

The value of the step, at worst, is the peak value of the sinusoidal voltage:

$$\hat{E} = \sqrt{2} \frac{U_n}{\sqrt{3}}$$

$U_n$  : phase-to-phase voltage

The current  $i(t)$  is determined by the following differential equation:

$$E(t) = (L_{up} + L) \frac{di}{dt} + \frac{1}{C} \int i$$

where: 
$$\begin{cases} E(t) = 0 & \text{for } t < 0 \\ E(t) = \hat{E} & \text{for } t \geq 0 \end{cases}$$

We shall solve this equation using Laplace transforms.

As a Laplace transform, the differential equation becomes:

$$\frac{\hat{E}}{s} = (L_{up} + L) [s I(s) - i(t=0)] + \frac{1}{Cs} I(s) - \frac{V_C(t=0)}{s}$$

The current is zero before energization and it is assumed that the voltage at the capacitor terminals is zero (worst case).

Hence:  $i(t=0) = 0$  and  $V_C(t=0) = 0$

thus giving us:  $\frac{\hat{E}}{s} = (L_{up} + L) s I(s) + \frac{1}{Cs} I(s)$

hence: 
$$I(s) = \frac{\hat{E}}{s \left[ (L_{up} + L) s + \frac{1}{Cs} \right]} = \frac{\hat{E}}{(L_{up} + L) \left[ s^2 + \frac{1}{C(L_{up} + L)} \right]}$$

Let us take: 
$$\omega = \frac{1}{\sqrt{C(L_{up} + L)}}$$

$$I(s) = \frac{\hat{E}}{(L_{up} + L) \omega} \frac{\omega}{s^2 + \omega^2}$$

Using the Laplace transform tables, we can deduce  $i(t)$ :

$$i(t) = \frac{\hat{E}}{(L_{up} + L) \omega} \sin \omega t$$

$$i(t) = \sqrt{\frac{2}{3}} U_n \sqrt{\frac{C}{L_{up} + L}} \sin \omega t$$

The maximum peak inrush current is thus:

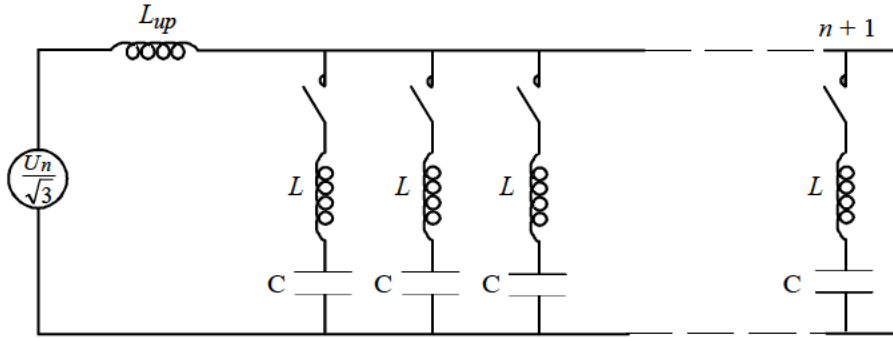
$$\hat{I}_{rush} = \sqrt{\frac{2}{3}} U_n \sqrt{\frac{C}{L_{up} + L}}$$

A and its frequency:

$$f_0 = \frac{\omega}{2\pi} = \frac{1}{2\pi \sqrt{C(L_{up} + L)}}$$

### **Switched steps bank**

The equivalent single-phase diagram during switched steps bank energization is shown in Figure B-2.



$L_{up}$  : upstream network inductance

$L$  : inductance of the connection linking the switching device to the bank

**Figure B-2:** equivalent diagram during switched steps bank energization

The peak inrush current  $\hat{I}_{rush}$  is maximum when  $n$  banks are in service and the  $(n+1)^{th}$  one is energized. The banks in service off load into the bank that has just been energized.

The upstream inductance is very high in relation to inductance  $L$  (see section 10.6.1, example 1:  $L_{up} = 385 \mu H$  and example 2:  $L = 2.5 \mu H$ ). The current supplied by the upstream part (network) is therefore neglected.

It is assumed that, at worst, upon energization the voltage at the terminals of each capacitor is  $V_C(t=0) = \hat{E} = \sqrt{2} \frac{U_n}{\sqrt{3}}$ .

The equivalent diagram is thus shown in Figure B-3.

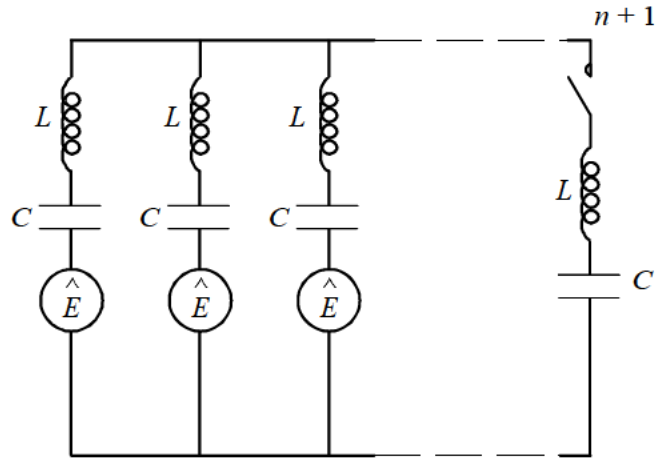
The diagram comprises  $n$  parallel-connected branches with an impedance of

$$Z = j L \omega + \frac{1}{j C \omega}$$

The equivalent impedance is therefore:

$$Z_{eq} = \frac{Z}{n} = j \frac{L}{n} \omega + \frac{1}{j n C \omega}$$

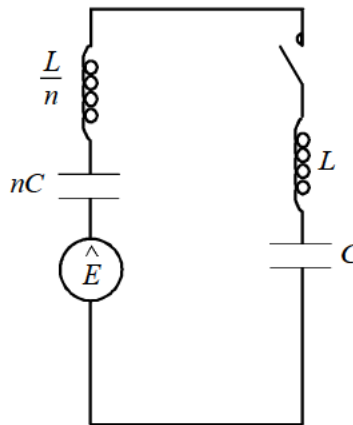




$\hat{E}$  : initial voltage condition at the capacitor terminals

**Figure B-3**

The diagram thus becomes that of Figure B-4.



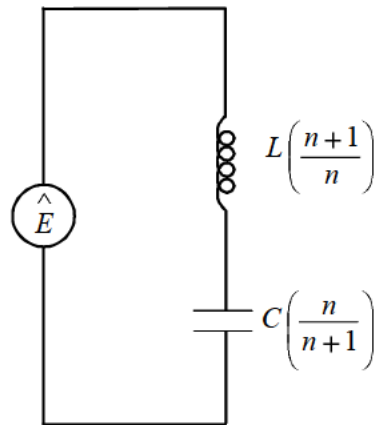
**Figure B-4**

We have two series-connected inductances:  $\frac{L}{n} + L = L \left( \frac{n+1}{n} \right)$

We have two series-connected capacitances:

$$\frac{1}{C} + \frac{1}{nC} = \frac{1}{C} \left( \frac{n+1}{n} \right) = \frac{1}{C \left( \frac{n}{n+1} \right)}$$

The equivalent diagram is thus that in Figure B-5.



**Figure B-5**

The equivalent diagram in Figure B-5 is the same as that of a fixed bank.

If we re-use the formula for a fixed bank, we immediately obtain:

$$\hat{I}_{rush} = \sqrt{\frac{2}{3}} U_n \sqrt{\frac{C \left( \frac{n}{n+1} \right)}{L \left( \frac{n+1}{n} \right)}}$$

$$\hat{I}_{rush} = \sqrt{\frac{2}{3}} U_n \frac{n}{n+1} \sqrt{\frac{C}{L}}$$

$$f = \frac{1}{2\pi \sqrt{LC}}$$

## Appendix C

# Voltage Peak Value and Current r.m.s Value, at the Secondary of a Saturated Current Transformer

Let us consider a primary current with a peak value  $\hat{I}_{1p}$  at the CT saturation limit.

Let  $\hat{I}_{2p}$  be the peak value of a primary current greater than  $\hat{I}_{1p}$ , which is thus going to saturate the CT.

Let  $\hat{I}_1$  and  $\hat{I}_2$  be the peak values of the currents at the CT secondary corresponding to  $\hat{I}_{1p}$  and  $\hat{I}_{2p}$  through the transformation ratio.  $\hat{I}_2$  is the design value that would be obtained if there was no saturation phenomenon.

The current curves look like those in Figure C-1 (see Figure 6-5).

According to section 6.1.2, the magnetic induction  $B$  is proportional to  $\int I dt$ .

The surface designed by the current is thus proportional to  $B$ . The current  $\hat{I}_1$  being at the saturation limit, the surface  $S_1$  designed by  $\hat{I}_1$  is proportional to the saturation magnetic induction.

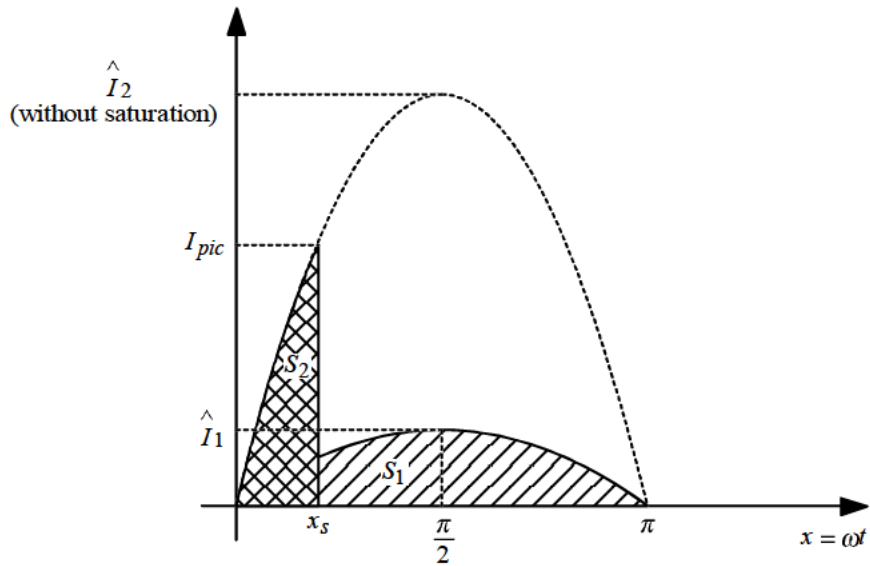


Figure C-1: form of current curves at the CT secondary

Let us take  $x = \omega t$  :

$$S_1 = \int_0^{\pi} \hat{I}_1 \sin x \, dx = \hat{I}_1 [-\cos x]_0^{\pi} = 2 \hat{I}_1$$

The surface  $S_2$  designed by the current  $I_2$  is:

$$S_2 = \int_0^{x_s} \hat{I}_2 \sin x \, dx = \hat{I}_2 [-\cos x]_0^{x_s} = \hat{I}_2 (1 - \cos x_s)$$

$x_s$  : saturation angle corresponding to the instant of saturation

The current  $I_2$  saturating the TC at angle  $x_s$ , the surface  $S_2$  is proportional to saturation magnetic induction, we thus have  $S_2 = S_1$ .

hence:  $\hat{I}_2 (1 - \cos x_s) = 2 \hat{I}_1$

$$x_s = \text{Arcos} \left[ 1 - 2 \frac{\hat{I}_1}{\hat{I}_2} \right]$$

**Voltage peak value**

Knowing the saturation angle, we can deduce the current peak value:

$$I_{peak} = \hat{I}_2 \sin x_s = \hat{I}_2 \sin \text{Arcos} \left[ 1 - 2 \frac{\hat{I}_1}{\hat{I}_2} \right]$$

$$I_{peak} = \hat{I}_2 \sqrt{1 - \left( 1 - 2 \frac{\hat{I}_1}{\hat{I}_2} \right)^2}$$

$$I_{peak} = \hat{I}_2 \sqrt{4 \frac{\hat{I}_1}{\hat{I}_2} - 4 \left( \frac{\hat{I}_1}{\hat{I}_2} \right)^2}$$

$$I_{peak} = 2 \sqrt{\hat{I}_1 \hat{I}_2 - \hat{I}_1^2}$$

$$I_{peak} = 2 \sqrt{\hat{I}_1 (\hat{I}_2 - \hat{I}_1)}$$

Let us assume that the current transformer has a resistive load  $R + R_w R$  (see section 7.6.1.1). The voltage peak is thus:

$$V_{peak} = (R + R_w + R_{ct}) I_{peak} = 2 \sqrt{(R + R_w + R_{ct}) \hat{I}_1 (R + R_w + R_{ct}) (\hat{I}_2 - \hat{I}_1)}$$

now:  $(R + R_w + R_{ct}) \hat{I}_1 = \sqrt{2} V_K$

and  $(R + R_w + R_{ct}) \hat{I}_2 = \sqrt{2} V_f$

$R_{ct}$  : resistance of current transformer windings

$R_w$  : resistance of wires connecting the current transformer to the protective relay

$V_K$  : current transformer knee-point voltage

$V_f$  : voltage that would occur at the CT terminals if there was no saturation phenomenon

Hence: 
$$V_{peak} = 2 \sqrt{2 V_K (V_f - V_K)}$$

***Determination of current r.m.s. value when the TC is saturated***

Over a half period, we have by definition:

$$I_{rms} = \frac{1}{\pi} \int_0^{x_s} \hat{I}_2^2 \sin^2 x \, dx = \frac{\hat{I}_2^2}{\pi} \int_0^{x_s} \left( \frac{1 - \cos 2x}{2} \right) dx$$

$$I_{rms} = \frac{\hat{I}_2^2}{2\pi} \left[ x - \frac{1}{2} \sin 2x \right]_0^{x_s}$$

$$I_{rms} = \frac{\hat{I}_2^2}{2\pi} \left( x_s - \frac{1}{2} \sin 2x_s \right)$$

$$I_{rms} = \hat{I}_2 \sqrt{\frac{x_s - \frac{1}{2} \sin 2x_s}{2\pi}}$$

where  $x_s = \text{Arcos} \left( 1 - 2 \frac{\hat{I}_1}{\hat{I}_2} \right)$

This formula is fairly complicated and we shall simplify it by assuming that the current transformer is highly saturated.  $x_s$  is thus close to zero, hence  $\sin x \cong x$  for  $x \leq x_s$ .

If we again use the method allowing  $x_s$  to be determined, we obtain:

$$S_2 = \int_0^{x_s} \hat{I}_2 \sin x \, dx = \int_0^{x_s} \hat{I}_2 x \, dx = \frac{\hat{I}_2}{2} x_s^2$$

By writing  $S_2 = S_1$ , we obtain:

$$\frac{\hat{I}_2}{2} x_s^2 = 2 \hat{I}_1$$

$$x_s = 2 \sqrt{\frac{\hat{I}_1}{\hat{I}_2}}$$

Thus:

$$\begin{aligned} I_{rms}^2 &= \frac{1}{\pi} \int_0^{x_s} \hat{I}_2^2 \sin^2 x \, dx = \frac{1}{\pi} \int_0^{x_s} \hat{I}_2^2 x^2 \, dx = \frac{1}{\pi} \hat{I}_2^2 \frac{1}{3} x_s^3 \\ &= \frac{1}{3\pi} \hat{I}_2^2 \left( 2 \sqrt{\frac{\hat{I}_1}{\hat{I}_2}} \right)^3 = \frac{8}{3\pi} (\hat{I}_2)^{\frac{1}{2}} (\hat{I}_1)^{\frac{3}{2}} \end{aligned}$$

since  $\sin x \cong x$

$$I_{rms} = \sqrt{\frac{8}{3\pi}} (\hat{I}_2)^{\frac{1}{4}} (\hat{I}_1)^{\frac{3}{4}} = \sqrt{\frac{8}{3\pi}} \sqrt{2} (I_2)^{\frac{1}{4}} (I_1)^{\frac{3}{4}} \begin{cases} \hat{I}_2 = \sqrt{2} I_2 \\ \hat{I}_1 = \sqrt{2} I_1 \end{cases}$$

$$I_{rms} = 1.3 (I_1)^{\frac{3}{4}} (I_2)^{\frac{1}{4}}$$

Determined in this way, the formula is valid for a highly saturated CT. For a current at saturation limit, i.e.  $I_2 = I_1$ , we see that  $I_{rms} = 1.3 I_2$ . The approximation error is thus 30%.

Through a numerical application, summarised in Table C-1, we can see that the approximation is correct for  $I_2 \geq 3 I_1$  and it always gives an excess value.

For a highly saturated CT, the r.m.s. value of the current is propotional to  $I_2$  to the power  $\frac{1}{4}$ .



$\frac{I_2}{I_1}$	true $I_{r m s}$	approximate $I_{r m s}$	error in %
1	1	1.3	+30
1.5	1.26	1.44	+14
2	1.41	1.55	+10
3	1.62	1.71	+6
5	1.89	1.94	+3
10	2.28	2.31	+1.3
$\infty$	$\infty$	$\infty$	0

**Table C-1:** comparison between the true r.m.s. value and the approximate value

In spite of the saturation, the r m.s. value of the current increases. An r m.s. overcurrent relay will thus be activated even if the CT saturates. However, for a dependent time protection (see section 7.1), the real time delay may be higher than the forecasted value for the calculated current. Indeed, the saturation strongly reduces the r m.s current value (power  $\frac{1}{4}$ ).

## Index

### A, B

AC generator protection 452  
Busbar protection 412

### C

capacitor bank protection 462  
circuit-breakers 11, 13, 15, 16, 21, 22, 24, 25, 27-29, 32, 33, 35, 36, 49, 56, 58, 60, 69, 80-82, 87, 99, 138, 139, 143, 145, 149, 152, 155-158, 160, 161, 163, 164, 166, 167, 207, 215, 229, 317-333, 335, 344-346, 349, 351, 353, 355, 356-359, 362, 366, 369, 372, 373, 375-378, 380-383, 385-389, 391, 392, 394, 395, 398-405, 407, 409, 411, 413, 424, 432-436, 440, 447, 452, 454, 455, 464, 469, 474, 477, 478, 483-486

### D

differential protection 63, 243, 244, 246, 249, 253, 256, 258, 259, 262, 265, 272, 273, 276, 278, 279, 341, 355, 356, 384, 385, 399, 403, 405, 407, 409-414, 424, 425, 437, 441, 444, 454, 455

### E

earth fault protection 68, 82, 210, 261, 307-309, 365, 366, 375, 378, 384, 386-389, 394, 399, 424, 443, 444, 455  
directional 64, 65, 137, 224, 226-229, 232, 234-236, 238, 241, 243, 366, 369, 376, 378, 380, 384, 385, 388, 394, 397, 398, 444  
earthing systems 53-55, 82, 114, 124, 126, 129, 138, 199, 239, 274, 307, 341, 362, 423, 443, 455  
at low voltage 54, 58  
comparison of different systems 58, 63  
definition 55, 61  
medium voltage 61, 63

### I

instrument transformers 173

### L

low voltage fuses 331  
LV  
networks 11, 31  
switchboards 31-36, 39-42, 107, 111, 112, 358

## **M, N**

motor protection 297, 439, 446, 448

### **MV**

fuses 334-338, 356

networks 11, 13, 16, 19, 25

switchboards 13, 18, 19, 42, 45, 49

network protection 302, 341, 361

neutral earthing 54, 66, 119, 126-129, 131, 133, 227, 228, 307, 308, 362, 367, 375, 377, 384, 385, 393-397, 424

## **O, P**

overvoltage protection 73, 238, 300, 301, 362, 380, 381, 387-389, 398, 444, 456, 457

phase overcurrent protection 162, 208, 211, 215, 217, 330, 346, 355, 371-373, 381, 382, 391, 432, 440, 453

## **S**

short-circuits 56, 58, 60, 61, 77-83, 87, 88, 91-99, 101, 105-107, 110-119, 125, 131, 133, 137-148, 150-154, 156, 157, 160-164, 166-168, 170, 171, 181, 182, 184, 185, 199,

207, 211, 215, 216, 218-223, 246, 248, 249, 252, 253, 255, 258, 259, 261, 263, 264, 273, 276, 293, 295, 297, 304, 311-313, 315, 317, 319-339, 341-344, 347, 349, 355, 358, 359, 361, 371, 372, 392, 395, 403, 405, 414, 417, 419-429, 432-436, 439-441, 451-455, 464-466, 472, 476-483, 485, 486

characteristics of 77, 81, 480

consequences of 77, 163

standard networks, examples of 44

supply source 13, 16, 20-24, 31, 33, 35, 36, 94, 116, 138, 152, 160

## **T**

transformer protection 344, 387, 414, 424, 436, 438

## **U**

undervoltage protection 297, 298, 444, 445, 457

## **V**

voltage transformers 73-75, 173, 198-205, 220, 224, 301, 302, 305, 369, 370, 389